

The AECOM logo is located in the top left corner of a dark blue vertical bar. It consists of a vertical line followed by the word "AECOM" in a white, sans-serif font.

AECOM

Repair Airfield Ramp Lights

Langley Air Force Base
Virginia

Specifications
50% Submittal Package

AECOM Project No. 60099060
May 15, 2009

BLANK PAGE

REPAIR AIRFIELD RAMP LIGHTS

PROJECT TABLE OF CONTENTS

DIVISION 01 - GENERAL REQUIREMENTS

01 06 00 REGULATORY REQUIREMENTS
01 11 00 SPECIAL CONDITIONS
01 12 00 ENVIRONMENTAL SPECIAL CONDITIONS
01 35 26 GOVERNMENTAL SAFETY REQUIREMENTS

DIVISION 03 - CONCRETE

03 30 53 MISCELLANEOUS CAST-IN-PLACE CONCRETE

DIVISION 26 - ELECTRICAL

26 05 00.00 40 COMMON WORK RESULTS FOR ELECTRICAL
26 09 23.00 40 LIGHTING CONTROL DEVICES
26 56 00 EXTERIOR LIGHTING

DIVISION 27 - COMMUNICATIONS

27 10 10 LANGLEY AFB TELECOMMUNICATIONS BUILDING CABLING SYSTEMS
STANDARDS

DIVISION 31 - EARTHWORK

31 00 00 EARTHWORK

DIVISION 32 - EXTERIOR IMPROVEMENTS

32 01 19 FIELD MOLDED SEALANTS FOR SEALING JOINTS IN RIGID
PAVEMENTS
32 01 26.71 GROOVING FOR AIRFIELD PAVEMENTS
32 13 13.03 AIRFIELDS AND HEAVY-DUTY CONCRETE PAVEMENT LESS THAN
10000 CUBIC YARDS

DIVISION 33 - UTILITIES

33 70 02.00 10 ELECTRICAL DISTRIBUTION SYSTEM, UNDERGROUND

-- End of Project Table of Contents --

BLANK PAGE

REPAIR AIRFIELD RAMP LIGHTS

SECTION 01 06 00

REGULATORY REQUIREMENTS

12/08

PART 1 GENERAL

1.1 SECTION INCLUDES:

- a. Regulatory Codes.
- b. Air Force Regulations.
- c. Permits.

1.2 REGULATORY CODES:

The latest editions of Federal, State, Industry, and local codes which govern this work include, but may not be limited to:

- a. Federal:
 1. Part 1926 - Chapter of Title 29, Code of Federal Regulations.
 2. Part 192 - Chapter of Title 49, Code of Federal Regulations.
 3. Corps of Engineers Safety and Health Requirement Manual, EM385-1-1.
 4. National Historic Preservation Act of 1966 as amended and 1980 as amended.
 5. Executive Order 13101 - "Greening the Government through Waste Prevention, Recycling, and Federal Acquisition"
 6. Resource Conservation and Recovery Act Section 6002
 7. FAR Clause 52.223-4 Recovered Materials Certification
 8. FAR Clause 52.223-9 Certification of Percentage of Recovered Material Content for EPA Designated Items Used in Performance of the Contract
 9. FAR Clause 52.223-10 Waste Reduction Program
- b. State:

Virginia State Enforcement.

1.3 AIR FORCE REGULATIONS:

The latest editions of the following Air Force Regulations shall apply to this work:

- a. MIL Handbook 1190, Facility Planning and Design Guide.
- b. Air Force Safety and Health Standard: AFR127-12, Air Force Occupational Safety and Health Program, and applicable standards.

REPAIR AIRFIELD RAMP LIGHTS

1.4 PERMITS:

a. The Contractor shall apply for and obtain the following permits, in addition to any other required permits, as applicable:

1. Disposal of Hazardous Materials.

b. The Contractor shall be responsible for payment of any fees associated with acquiring the required permits and should reflect those costs in his/her bid proposal.

PART 2 - PRODUCTS: NOT USED.

PART 3 - EXECUTION: NOT USED.

-- End of Section --

SECTION 01 11 00

SPECIAL CONDITIONS

REVISED 15 MAY 2008

PART 1 GENERAL

1.1 SUBMITTALS

The following items specified herein shall be submitted in accordance with SUBMITTAL PROCEDURES; paragraph 1.2.1.

SD-01 Preconstruction Submittals
Submittals which are required prior to a notice to proceed commencing work on site.

- Certificate of Insurance
- Surety Bonds
- List of Proposed Sub Contractors
- List of Proposed Products
- Construction Schedule
- Submittal Register
- Health and Safety Plan
- Quality control (QC) Plan
- Environmental Protection Plan
- All Employee Names and Social Security Numbers

SD-03 Product Data
Material Safety Data Sheet (MSDS) for each item
Quality Control (QC) Report

SD-11 Closeout Submittals
Deliverables
Three copies of Computer-Aided Drafting and Design (CADD) digital final as-built drawings on CD's
One As-Built (Redline) Drawing
Warranty of Construction
Equipment Warranty Certificate

1.1.1 SUBMITTAL PROCEDURES

1.1.1.1 Schedule of Material Submittals (Air Force Form 66)

Information, shop drawings, certificates, test data, etc., listed on the attached AF Form 66, Schedule of Material Submittals, shall be submitted for approval by the Contracting Officer, or his/her designated representative in accordance with the General Provisions. Whenever in this contract materials or drawings are required to be submitted by the Contractor to the Contracting Officer for approval and the material or drawings submitted are at variance with the specifications or Government drawings, but are, nevertheless, approved by the Contracting Officer, inadvertently and without consciousness of the variance, and regardless that a closer review could have revealed the variance, then such approval shall not be final unless the Contractor expressly noted on the material submittal or drawing that "this material or drawing varies from specifications in the following aspects -" or uses other works of similar

REPAIR AIRFIELD RAMP LIGHTS

clear meaning. In the event of such an inadvertent, erroneous approval, the Contracting Officer, upon discovering the variance at any stage, has the right to require the Contractor to do such rework and/or material replacement as is necessary to obtain compliance with the specifications, and the expense of such rework and/or material replacement shall be borne solely by the Contractor.

1.2 SCOPE OF WORK

The work under this project consists of the demolition and replacement of existing high mast poles, lighting equipment, and lighting power sources on the east and west aprons of the Langley Air Force Base airfield. Work includes demolition of existing poles, pole foundations, lighting fixtures, light fixture mounts, lamps, ballast equipment, cables, switches, transformers, splices, and other necessary civil and electrical infrastructure work. Work includes construction of replacement poles, pole foundations, lowering devices, light fixtures, light fixture mounts, lamps, ballast equipment, lighting control equipment and related appurtenances. Work includes construction and installation of replacement power sources, to include all earthwork, trenching, conduit, cables, switches, transformers, splices and other necessary civil and electrical infrastructure work.

1.2.1 Work Hours

Normal duty hours for Langley Air Force Base are 0730 through 1630, Monday through Friday. Work on weekends, recognized Federal holidays, or other than normal duty hours must be coordinated with the Contracting Officer (CO) or his/her designated representative.

1.2.2 General Working Conditions

- a. Work shall be performed in such a manner as to cause minimum disruption to the users in the area.
- b. The Contractor shall notify the Contracting Officer or his/her designated representative when he intends to work so Government inspection can be provided while work is in progress.

1.3 ORDER OF WORK

The Contractor shall coordinate all work with the Contracting Officer, or his/her designated representative, and the Base Civil Engineer. Before starting work at the job site, provide five days notice to the Contracting Officer or his/her designated representative and the Chief of Contract Management at 764-3268.

1.4 PHASING OF WORK

The east and west aprons will remain operational during the period of contract performance. Security lighting for aircraft must be maintained. The contractor will coordinate phasing with the Contracting Officer in order to minimize the disruption to operations.

1.5 APPLICABLE CODES AND REGULATIONS

The latest edition of the following Building Codes shall be used for all construction under this contract:

International Building Code

REPAIR AIRFIELD RAMP LIGHTS

International Mechanical Code
International Plumbing Code
National Electrical Code (NEC)
ANSI C-2, National Electrical Safety Code (QIESC)
Life Safety Code, NFPA 101
National Fire Protection Association (NFPA)
MIL Handbook 1190
Unified Facilities Criteria (UFC) 3-600-01

NOTE: If there is a conflict between these codes or regulations and these contract specifications, the most stringent requirements shall apply at all times.

1.6 SALVAGE

Title to all materials and equipment to be demolished, excepting items indicated as Government salvage, shall be vested to the Contractor upon removal from the base except as noted below. The Government will not be responsible for the condition, loss or damage to such property after notice to proceed. All unsalvageable material will be disposed of legally off-base.

1.6.1 Items Salvaged for the Government

The Contractor shall salvage the following existing materials to the Government as indicated below. Salvaged materials shall be cleaned, sorted, identified, bundled, boxed, etc. and delivered to the collection location identified below.

ITEM	DELIVERY LOCATION
Transformers	Coordinate with Contracting Officer.

1.7 CONSTRUCTION STANDARDS

1.7.1 General

The Contractor is reminded that the construction site must be operated and maintained according to these specifications and is subject to inspection and enforcement according to all federal, state and local codes/regulations.

1.7.2 Office Trailers and Storage Units

1.7.2.1 Office Trailers

If a trailer is required for work and at the discretion of the Government, an office trailer may be located at the project site. The Contractor shall request Contracting Officer approval for the trailer location. The Contractor shall make the request in writing at least fourteen calendar days prior to placement of trailer at site. All office trailers shall be located in areas as directed by the Contracting Officer or his/her designated representative. Any office trailer shall be not more than 10' x 32' in size, provided with a skirt on all sides, in like new condition, and painted either Langley Brown (Federal Standard 595a, 20100), Langley Beige, or white. Office trailers in need of painting and / or repairs or that are in an unsightly condition will not be allowed at the project site. Displayed on the exterior of all trailers shall be a nameplate which has the name of the Contractor's company, name for Contractor's point(s) of contact (POC) and telephone number where he or she can be reached, contract number, project number, title and date trailer was placed on site where

REPAIR AIRFIELD RAMP LIGHTS

located.

1.7.2.2 Storage Units

The Contractor shall request Contracting Officer approval for the siting, size and color of Storage Units, CONEX boxes and dumpsters. The Contractor shall not bring any such items to the job site without the Contracting Officer's approval. All storage units shall be painted Langley Brown (Federal Standard 595a, 20100), Langley Beige or white. Displayed on the exterior of all storage units shall be a nameplate which has the name of the Contractor's company, name for Contractor's point(s) of contact (POC) and telephone number where he or she can be reached, contract number, project number, title and date unit was placed on site where located.

1.7.3 On-Site Storage Units

Availability and size of material lay down area shall be restricted as noted on the contract documents or as discussed during the preconstruction conference. The Contractor shall consolidate all bulk and/or large quantities of materials at the construction site in area(s) approved by the CO. All such items shall be stored neatly grouped together. Bulky or unsightly construction materials, heavy and/or light equipment, or tanks shall not be delivered to or stored on the construction site for any period longer than seven calendar days prior to use, installation in the project, or start of construction. The Contractor shall store all supplies and equipment on project site so as to preclude theft or damage. Protection and security for materials and equipment on site is the sole responsibility of the Contractor. The Contractor shall not use any area(s) for material or equipment storage that has not been approved by the CO or his/her designated representative.

1.7.4 Fencing and Screening

Contractor shall enclose the lay down area with a chain link fence that has been erected to a minimum height of six feet. Contractor's lay down area shall also be screened from view. Screening shall be fabricated of 100% Polypropylene, woven, 92% blockage fabric that has been mechanically attached to the fence for the full height of the fence. The edges of each section of screening fabric shall be finished with a reinforced hem. Attachment points shall be reinforced fabric built into the hem or metal grommets built into the hem. All fabric used for screening of the construction lay down area shall be UV rated and dark brown or dark bronze in color. **Fence screening fabric shall be inspected weekly to insure all sections remain properly installed and taut at all times.**

1.7.5 Locksets

All locksets shall be compatible with the "Best Lock Corporation 7-Pin Interchangeable Cores", no specific brand. Cores themselves must work with the existing master system in use at Langley AFB (Best Premium WB Keyway 7-Pin Cores, Part Number 1CP7WB2).

1.7.6 Communications

The contractor shall design and install new communications in accordance with the most current version of 1ST COMM PREMISE WIRE DISTRIBUTION SYSTEM SPECIFICATIONS (Langley AFB).

REPAIR AIRFIELD RAMP LIGHTS

1.8 CONTRACTOR OPERATIONS

1.8.1 Grassy Areas

Grass and weed growth in excavated materials that are stockpiled on site shall be controlled and/or cut weekly. Weeds and grass within the construction site shall also be controlled and/or cut weekly and any bushes or shrubs shall be trimmed monthly. Areas disturbed by construction and/or those areas required by the plans to be "re-seeded" shall be re-established by hydroseeding only. Straw shall not be used as a cover for freshly seeded areas.

1.8.2 Privately Owned Vehicles (POVs)

POVs used by Contractor personnel to commute to work are required to park in existing parking lots. Contractor or Contractor's employees, including sub-contractors, shall not park any personally owned vehicle (POV) or company and/or delivery vehicle on grassy areas near or in the construction site without prior approval from the Contracting Officer, or his/her designated representative. When allowed, parking on grassy areas will only be for short-term delivery purposes (to include heavy tools, equipment, construction materials, etc.). Use designated hard surfaces or existing parking lots near or within the project site for parking of POVs or company and/or delivery vehicles. Tire and track impressions (ruts) created on wet or soft soil by vehicles and/or equipment used in the Contractor's operations shall not be left for more than one day after removal of such vehicle or equipment that caused the rutting. The Contractor shall restore the affected area(s) of the site to its original condition within that one day period.

1.8.3 Site Cleanup

During construction, the Contractor shall maintain all areas in a neat and orderly manner. Contractor shall keep the construction site cleaned daily of all construction trash, trash generated by employees, debris, and/or demolished building materials. If the work areas are not kept neat and orderly, the Contractor must return to the area to correct the unacceptable condition. During the laying of asphalt roads, streets and/or parking surfaces, areas soiled by residual asphalt shall be cleaned daily. The Contractor shall treat with lime entrances and exits to asphalt work site at his/her own expense.

1.8.4 Access Routes

Access routes to this project shall be limited through the Base as shown on the plans. The Contractor shall not use the gates at King Street Bridge or West Gate (Sweeney Boulevard) for haul route entry. When exiting the base, the haul route shall be through the West Gate only.

1.8.5 Removal of Formwork

The Contractor shall remove all concrete formwork and boards within fourteen calendar days after concrete pour.

1.8.6 Noise Control

The Contractor shall comply with all applicable state, local and installation laws, ordinances and regulations relative to noise control, to include applicable quiet hours exclusive to Langley Air Force Base. Work

REPAIR AIRFIELD RAMP LIGHTS

site is in a residential area of Langley Air Force Base. There shall be absolutely no construction activities in or around the construction site prior to or after the hours designated in "Work Hours" paragraph above without an approval from the Contracting Officer, or his/her designated representative. This restriction also applies to holidays.

1.8.7 Excavations

All trenches/excavations shall be backfilled and compacted to 85% of maximum density. Trenches will be top dressed with no less than three inches of shifted topsoil and then compacted. The finished area will be free of all debris, rocks and then graded to conform to the surrounding area. The area will be hydro seeded with fescue (cool weather) or Bermuda grass (hot weather). Seed shall contain no less than 99% pure seed, 0% weed seed and spread at a rate of 8-10 pounds per 1,000 square feet.

1.8.8 In-Ground Obstructions

Any type of raised obstructions shall have the surrounding soil backfilled and compacted to 85% of maximum density, and graded. The area will be top dressed as above to within three inches of the top of obstruction. Ground level obstructions will have the area dressed to the level of obstruction. The area will be hydro seeded with fescue (cool weather) or Bermuda grass (hot weather). Seed shall contain no less than 99% pure seed, 0% weed seed and spread at a rate of 8-10 pounds per 1,000 square feet.

1.8.9 Architectural Compatibility

Due to Langley AFB's distinct historic architecture and the high visitor traffic it receives, several special actions are required during construction:

- a. The Contractor is solely responsible for spillage from his/her vehicles and such spillage shall be cleaned up immediately. For the duration of this contract and on a daily basis, the Contractor shall remove from all base roads and streets asphalt, mud, soil, rocks, trash and debris that result from his/her construction operation on base. All roads or streets affected shall be cleaned before close of business on the particular day affected. In the case of asphalt, roads will be cleaned and/or treated with lime immediately upon detection.
- b. Newly placed concrete curbing and sidewalks shall match existing, adjacent concrete in color and texture.
- c. Unprimed or factory-finished equipment installed on the exterior of facilities shall be painted with two coats of brown paint to match existing equipment.

1.8.10 Patching

All holes in walls or other parts of the structure where material or equipment is removed or replaced shall be sealed, painted, caulked or plugged neatly with original type of materials to match the existing part of the structure so involved. All above work and materials shall be approved by the Contracting Officer or his/her designated representative.

REPAIR AIRFIELD RAMP LIGHTS

1.8.11 Repairs

Replace or restore all pavement, curb and gutter, and sidewalk disturbed by operations under this contract to the original condition, except where shown or specified otherwise. Compact backfill in pavement repairs with mechanical tampers to affect a density equal to adjacent subgrade. Replace pavement with equal materials and equal thicknesses to that removed, unless indicated otherwise. Each pavement area shall be replaced immediately after the work operation for that area is completed. At the Contractor's option, a temporary repair with a surface of bituminous concrete may be made immediately and removed and the permanent repair made before completion of the contract.

1.8.12 Marking

Contractor shall not mark any curb or pavement with paint.1.9.14
Accidental Spills

1.8.13 Protection Requirements

The Contractor shall at all times protect and preserve the property of the Government which is within the work area and could be affected by the accomplishment of the work specified and indicated, and all parties and individuals within or near the work areas who could be endangered by the installation of the work.

1.8.14 Accidental Spills

In the event of fuel spillage during the performance of this contract, the Contractor shall be responsible for its containment, clean-up and related disposal costs. The operator shall have sufficient spill supplies readily available on the pumping vehicle or at the site to contain any spillage. In the Event of a Contractor related release, the Contractor shall immediately notify the Environmental Management Office and take appropriate actions to correct its cause and prevent future occurrences. If the federal, state, or local authorities assess any monetary fine, penalty or assessment related to the release of any substance by the Contractor, his/her employees, or agents during the performance of this contract, the Contractor shall be solely liable for its payment and authorizes the United States Air Force to withhold such form of payment and otherwise indemnify and hold the United States Air Force harmless.

1.9 ENVIRONMENTAL PROTECTION

PLEASE REFER TO LANGLEY AFB SECTION 01 12 00, ENVIRONMENTAL SPECIAL CONDITIONS.

1.10 PROTECTION OF GOVERNMENT PROPERTY

1.10.1 General

The Contractor shall at all times protect and preserve the property of the Government which is within the work area and could be affected by the accomplishment of the work specified and indicated, and all parties and individuals within or near the work areas who could be endangered by the installation of the work. Protection requirements include protecting the interior of the facility from inclement weather. Any actions necessary for adequate protection are solely the Contractor's responsibility. Any temporary boarding of windows or doors must be painted Langley Brown or

REPAIR AIRFIELD RAMP LIGHTS

Langley Beige to match the exterior.

1.10.2 Protection of Equipment

Contractor is required to cover equipment that is to remain in place within the area of contract operations and protect it against damage or loss and store equipment that is removed in performance of work where directed or use in work as required by drawings and specifications. Equipment temporarily removed shall be protected and returned equal to its condition prior to starting work at no additional expense to the Government. Security for equipment or material that is to be reused and is removed for temporary storage shall be the sole responsibility of the Contractor.

1.10.3 Protection of Grounds

Contractor shall provide protective barriers for all grass, trees, shrubs, sidewalks, curbs and gutters within the construction boundary. Furthermore, such items, including grass, outside the construction boundary shall also be protected during delivery of materials and/or moving of equipment. Damages caused by the Contractor to existing grounds, plants, pavements, utilities, work by others, fixtures, or furnishings shall be repaired by the Contractor. Such repairs shall be of as good condition as existed before the damaging, unless such existing work is scheduled for removal or replacement by the work requirements of the contract. This requirement also pertains to grading of site to remove all clods and grade irregularities prior to final inspection and acceptance. The Contractor may be required to install temporary fencing to protect the site, at no cost to the Government.

1.11 SAFETY

1.11.1 Safety Barriers and Signs

Contractor shall provide barricades, traffic control signs and construction safety signs that meet industry standards. Actual location, size and final arrangement of these items shall be discussed and approved by the Contracting Officer prior to installation. Such approved items shall be of uniform size, design and color. All cones, barricades, warning lights, temporary signs and protective devices shall conform to the current requirements of the Manual of Uniform Traffic Control Devices for Streets and Highways (MUTCD) and the US Army Corps of Engineers Safety and Health Requirements Manual EM 385-1-1.

1.11.2 Employee Health and Safety

1.11.2.1 Compliance

In order to provide safety controls for protection to the life and health of employees and other persons; for prevention of damage to property, materials, supplies, and equipment; and for avoidance of work interruptions in the performance of this contract, the Contractor shall comply with all pertinent provisions of the Corps of Engineers Manual, EM 385-1-1 (2003), entitled "Safety and Health Requirements Manual," as amended. The Contractor will also take or cause to be taken such additional measures as the Contracting Officer, or his/her designated representative may determine to be reasonably necessary for the purpose. A copy of the manual is available for review in the Civil Engineering Contract Management Section office (Bldg. 328) or copies can be obtained from the Government Printing Office, Washington DC 20402.

REPAIR AIRFIELD RAMP LIGHTS

1.11.2.2 Subcontractor's Compliance

Compliance with the provisions of this clause by subcontractors will be the responsibility of the Contractor.

1.11.2.3 Safety Records

The Contractor will maintain an accurate record of, and will report to the Contracting Officer or his/her designated representative in the manner and on the forms prescribed by the Contracting Officer or his/her designated representative, exposure data and all accidents resulting in death, traumatic injury, occupational disease, and damage to property, materials, supplies and equipment incident to work performed under this contract.

1.11.2.4 Notification of Non-Compliance and Corrective Action

The Contracting Officer or his/her designated representative will notify the Contractor of any noncompliance with the foregoing provisions and the action to be taken. The Contractor shall, after receipt of such notice, immediately take corrective action. Such notice, when delivered to the Contractor or his/her representative at the site of the work, shall be deemed sufficient for the purpose. If the Contractor fails or refuses to comply promptly, the Contracting Officer or his/her designated representative may issue an order stopping all or part of the work until satisfactory corrective action has been taken. No part of the time lost due to any such stop orders shall be made the subject of claim for extension of time or for excess costs or damages by the Contractor.

1.11.3 Applicable Publications

The publications listed below form a part of this specification to the extent referenced. The publications are referred to in the text by basic designation only.

a. Code of Federal Regulations (CFR):

(1) OSHA General Industry Safety and Health Standards (29 CFR 1910), Publication V2206, OSHA Construction Industry Standards (29 CFR 1926). One source of these regulations is OSHA Publication 2207, which includes a combination of both Parts 1910 and 1926 as they relate to construction safety and health. They are for sale by the Superintendent of Documents, U. S. Government Printing Office, Washington, DC 20402.

b. National Emission Standards for Hazardous Air Pollutants (40 CFR, Part 61).

c. Federal Standard (Fed. Std.):

(1) 313A Material Safety Data Sheets, Preparation and the Submission to the BioEnvironmental Office on Langley AFB. Safety and Health Requirements Manual, EM 385-1-1.

(2) Use of Asbestos Containing Material or any Class 1 ozone dep-leting chemical compounds is prohibited at Langley AFB, DA Circular 40-83-4.

(3) Work covered by this section: This section is applicable to

REPAIR AIRFIELD RAMP LIGHTS

all work covered by this contract.

(4) Definition of Hazardous Materials: Refer to hazardous and toxic materials/substances included in Subparts H and Z of 29 CFR 1910 and to others as additionally defined in Fed. Std. 313. Those most commonly encountered include asbestos, lead paint, polychlorinated bi-phenyl's (PCBs), explosives and radioactive material, but may include others. The most likely products to contain asbestos are sprayed-on fireproofing, insulation, boiler lagging and pipe covering.

1.11.4 Precautions Against Hazards

1.11.4.1 Welding, Cutting and Burning

All welding and cutting operations shall be done in accordance with nationally recognized good practice. The current publications of the American Welding Society, 2501 NW 7th Street, Miami FL 33125, and the National Fire Protection Association, 470 Atlantic Ave., Boston MA 02110, shall be used as a minimum standard of nationally recognized safety procedures in welding and cutting.

The Contractor shall provide the necessary methods of fire extinguishment and fire prevention, and before operations begin, clear all welding and cutting operations with the representative of the Contracting Officer or his/her designated representative. The Contractor shall request and receive an AF Form 592, USAF Welding and Brazing Permit, before preparing for such operations.

The Contractor shall discontinue all burning, welding or cutting operations one hour prior to the end of the normal workday. The Contractor shall provide a workman to remain at the site for thirty minutes after discontinuing the above operations. This workman shall make a thorough inspection of the area for possible sources of latent combustion. Any unsafe conditions shall be reported to the Fire Department for their investigation - EMERGENCY PHONE NO 911.

1.11.4.2 Open Flames

The use of open-flame heating devices **will not** be allowed except by special permission of the Contracting Officer or his/her designated representative. Such permission will not be granted unless the Contractor has taken all venting precautions. Burning trash, brush or trees on the job site will not be allowed unless specific approval is granted for each incident by the Contracting Officer or his/her designated representative. Approval for the use of open fires and open-flame heating devices will in no way relieve the Contractor from the responsibility of any damage incurred because of fires.

1.11.4.3 Flammable Liquid Storage

Flammable liquids shall be stored and handled in accordance with the Flammable Liquids Code (No. 30) of the National Fire Protection Association. Flammable liquids shall not be stored in the Contractors storage trailers.

1.11.4.4 Technical Services

The Langley Fire Department, Technical Services Section, (757) 764-4275, is

REPAIR AIRFIELD RAMP LIGHTS

available for assistance concerning fire hazard questions.

1.12 SECURITY

1.12.1 General Base Requirements

Access to Langley AFB is restricted to those Contractor and subcontractor employees required for the performance of this contract and only for the performance period of this contract. Contractor passes are issued by the Pass and Registration Section, Bldg 15 (Room 103), after a signed letter from the Contractor listing all employee names and social security numbers has been delivered to and approved by the Contracting Officer or his/her designated representative. Procedures for requesting Base Passes for employees and Contractor vehicles will be further explained during the preconstruction conference.

1.12.2 Emergency Security Situations

If a security violation is detected from any cause, it may result in the cessation of all work and evacuation of the area by all Contractor personnel to a point to be determined by the Security Police Supervisor at the scene. The control of construction personnel under these conditions is a Security Police Officer and their orders shall be followed in detail. Construction will be permitted to resume as quickly as possible. The individual causing the violation may be apprehended, and if so, will be processed and released to a responsible supervisor; such person might be away from his/her work site as long as 1 to 1½ hours. If a hostile situation is detected as a result of the construction activity, the entire crew may be removed from the area and detained until competent authority approved their release. All Security Police exercises will be scheduled to not interfere with construction personnel or with their work.

1.12.3 Work In Special Security Areas

1.12.3.1 Escorts

Government shall provide all escorts required for access to security areas while working on construction projects at LAFB.

1.12.3.2 Applicable Security Criteria

AFI 31-101, The Air Force Installation Security Program shall apply to construction projects at Langley AFB.

1.12.4 Restricted Area

Text

1.12.4.1 General

All work to be performed on this project is within the boundary of a USAF Restricted Area and will be confined to the immediate vicinity of the East and West Airfield Aprons. Full operational status of the mission and Security Forces will be maintained throughout the contract period. To facilitate contract work while preserving strict security, a Contractor free zone will be established around each work area, and a combination of entry control, internal movement and surveillance techniques will be employed. Security procedures and USAF Security Police actions will take precedence over all concerns at the time of emergencies or mission

REPAIR AIRFIELD RAMP LIGHTS

operations. The use of dead-ly force is authorized to protect government resources.

1.12.4.2 Entry Control

Entry into the work areas will be through the use of Air Force Form 75, Vis-itor Pass and an Entry Authority List provided by the Contractor to the Chief of Security Police. The Base Commander retains the authority to deny entry to any person(s). Security Police and Escort Officials execute this authority for the Base Commander.

1.12.4.3 Indentification Permits

The Contractor is responsible for requiring each employee to display an identification permit while within the area. All identification permits shall be immediately delivered to the Contracting Officer or his/her desig-nated representative, for cancellation upon release of any employee or ter-mination of contract work, whichever is sooner. All Contractor personnel shall stay within the boundaries of the guarded work zone. Subcontractors, material deliverers or other workers must be pre-identified 48 hours in ad-vance of their arrival by an Entry Authority List approved by the Contract-ing Officer or his/her designated representative. This list will contain the full name, SSAN and the base pass number (Air Force Form 75). If this notification is not received, some delay may be expected.

1.12.4.4 Search Procedures

Search procedures will be in effect at all times. Each time a Contractor personnel enters the secure area the vehicle and cargo, briefcases, toolbox-es, etc. may be searched. Individuals are also subject to search by the use of a metal detector. Primary emphasis will be placed on locating explosive devices, instruments of espionage, unauthorized individuals and other ob-jects of a suspicious nature. The Contractor shall store tools and cargo that are not required for the job in his/her own facility that will be lo-cated in a designated area.

1.12.4.5 Internal Controls

The boundaries of the designated work areas will be under surveillance of armed guards. Contractor personnel must remain within the boundaries of the designated area and shall enter or depart the work areas only through the designated Exit / Entry Point. The Contractor shall insure all persons are aware of the boundaries, and that they are to remain within the work zone.

1.12.4.6 Security Manager

The Contractor shall designate a representative as Security Manager to coor-dinate security matters. At least 48 hours in advance of a change in work hours, the Security Manager shall notify the Contracting Officer or his/her designated representative, who will notify the Security Police.

1.12.4.7 Housekeeping

The Contractor shall keep the work area neat and tidy. Clean up shall be accomplished daily, and all piles of materials, equipment and debris that could afford cover or concealment for unauthorized persons shall be removed from the area. Storage areas will be designated and the Contractor shall not store anything within thirty feet of the boundary fence.

REPAIR AIRFIELD RAMP LIGHTS

1.12.4.8 Power Interruptions

Power interruptions necessary as a part of the construction project shall be coordinated with the Contracting Officer or his/her designated representative who will, in turn, notify the Base Civil Engineer, Central Security Control, and the area occupants. The request for interruptions shall include reason, date, time, area affected and duration, and shall be submitted to allow notification at least two days in advance of the interruptions.

1.12.4.9 Repair Responsibilities

Any damages or alteration to any security facility, i.e., fence, lighting, communication cables, will be repaired, replaced, or suitable substitute provided by the Contractor prior to night fall of the day such action occurred or was detected.

1.12.4.10 SOvernight Storage of Construction Machinery

All construction machinery that is self-propelled (tractors, back hoes, dozers, trucks, etc.) will not be allowed to remain within the Restricted Area overnight. Such vehicles must be parked in a designated area 30 feet beyond the boundary fence, locked, and keys removed.

1.12.4.11 Mission Operation

Occupant and Security Operations will be continuous throughout the contract period and will necessitate nominal constraints on Contractor operations. Planning between the Contracting Officer or his/her designated representative and mission units can eliminate most constraints except those caused by unforeseen events. During any movements of security resources into or from the Restricted Area, construction will be halted prior to the movement and the construction crew will be relocated to an area away from the convoy route and / or destination. Under no circumstance will the reason for this relocation be announced to the Contractor. The Site Supervisor / Convoy Commander will be responsible for insuring all Contractor personnel are positioned away from the convoy routes and destination. Contractor personnel shall obey all instructions of Security Police that pertain to their movement and activity. However, Security Police will not interfere or halt any affect on rate of work or quality of work; their interference will pertain only to that necessary to protect security resources, if present.

1.12.4.12 Delays In Entering And Leaving Work Area

The Contractor may experience delays due to compliance with entrance/exit requirements of restricted/controlled areas. The Contractor shall not be compensated for reasonable delays in accessing the site. Also, due to the nature of restricted areas, the Contractor may be requested to leave the restricted area at any given time. The Contracting Officer may extend the contract performance time when area designations change while the Contractor is working.

1.12.4.13 Safety

Flame and spark producing equipment (i.e., matches, lighters, vehicle cigarette lighters) shall be surrendered at the Entry Control Point prior to entry to the area. Smoking within the area is prohibited except in

REPAIR AIRFIELD RAMP LIGHTS

Contractor provided approved smoking areas. The use of flame and spark producing equipment within the area is discouraged; however, in the event that it is necessary to use electric welders, oxygen-acetylene torches or other spark producing devices, the Contractor shall notify the Contracting Officer or his/her designated representative. Should a hazardous condition arise during the use of such devices, contact the Fire Department (Main Base: 911; Bethel Manor Housing: 865-1042). All Contractor personnel are subject to base safety and traffic regulations and may be barred from motor vehicle operation for cause.

1.12.5 Airfield Requirements

1.12.5.1 Contact Base Operations

Contractor shall contact LAFB Base Operations (764-4292, 764-2508), for construction restrictions involving the flightline, taxiway and runway areas and shall comply with Air Force Instruction AFI 13-213.

1.12.5.2 Radio Communication with Tower

Two-way radio contact on VHF Radio capable of communication with the Air Traffic Control Tower on the ramp net (163.4625 MHz) is required at all times for all personnel and groups of personnel working on the flightline, taxiways and runways. Contractor shall coordinate radio issuance with the project inspector.

1.13 HISTORIC DISTRICT/ARCHITECTURAL COMPATIBILITY

Due to the distinct historic architecture and the high visitor traffic LAFB receives, several special actions are required during construction and are listed herein.

1.13.1 Newly Placed Concrete

When placing concrete adjacent to existing concrete, all newly placed concrete curbs, gutters and sidewalks shall match existing adjacent concrete in color and texture. Miami Buff is the predominate color used on LAFB. All concrete that is newly placed by the Contractor shall be Miami Buff in color unless specifically noted otherwise in the contract documents or instructed otherwise by the Contracting Officer or his/her designated representative.

1.13.2 Unprimed or Factory Finished Equipment

Unprimed or factory-finished equipment installed on the exterior of facilities shall be painted with two coats of brown paint to match existing equipment.

1.13.3 Patching

All holes in walls or other parts of the structure where material or equipment is removed or replaced shall be sealed, painted, caulked or plugged neatly with original type of materials to match the existing part of the structure so involved. The Contracting Officer or his/her designated representative shall approve all above work and materials.

1.13.4 Pavement Repairs

Replace or restore all pavement, curb and gutter, and sidewalk disturbed by

REPAIR AIRFIELD RAMP LIGHTS

operations under this contract to the original condition, including any markings or striping, except where shown or specified otherwise. Compact Backfill in pavement repairs with mechanical tampers to affect a density that is equal to adjacent subgrade. Replace pavement with equal materials and equal thickness to that removed, unless indicated otherwise. Each pavement area shall be replaced immediately after the work operation for that area is completed. At the Contractor's option, a temporary repair with a surface of bituminous concrete may be made immediately and removed and the permanent repair made before completion of the contract.

1.13.5 Marking Restrictions

Contractor shall not mark any curb or pavement with paint unless directed by the Contracting Officer or his/her designated representative.

1.14 RECORDING AND PRESERVING HISTORICAL AND ARCHAEOLOGICAL FINDS

1.14.1 Preservation

All items having any apparent historical or archeological interest, which are discovered in the course of any construction activities shall be carefully preserved. The Contractor shall leave the archeological find undisturbed and shall immediately report the find to the Contracting Officer or his/her designated representative so that the proper authorities may be notified.

1.14.2 Rehabilitation

All repair, maintenance, and construction must be completed in a manner that is consistent with the Secretary of the Interior's "Standards for Historic Preservation Projects" and the Secretary's "Illustrated Guidelines for Rehabilitating Historic Buildings".

1.15 EXCAVATION REQUIREMENTS

The Government will furnish the Contractor with an approved AF Form 103, BCE Work Clearance Request, indicating any special precautions and/or areas that will be marked (for utilities). The contract drawings, AF Form 103 and marking will indicate all information the Government has knowledge of, but will not indicate all conditions that may occur in the field. The Contractor shall not begin (work) excavation until the Clearance Request is issued. The Contractor shall be responsible for removing all markings made for his benefit as soon as the need for an individual mark is passed. The Government will mark utilities one time only. Maintaining these marks or additional marking is the responsibility of the Contractor.

1.15.1 Acquiring a Work Clearance Request (Air Force Form 103)

A coordinated and approved Work Clearance Request is required prior to any excavation activities. The Contractor shall submit a request to the Project Inspector 14 days prior to the start of excavation work. All requests must be initiated not later than Thursday of any week to be inserted into the Work Clearance approval process for the following week. The Contractor will be notified to attend a Work Clearance scheduling meeting. At the Work Clearance meeting, the Contractor will receive an AF Form 103, instructions for completing the form, and a date and time for utilities to be marked. The Contractor shall not commence excavation prior to obtaining an approved AF Form 103. After all respective utilities have been marked and verified by the Project Inspector, the Contractor shall

REPAIR AIRFIELD RAMP LIGHTS

return the original AF Form 103 to his/her respective Project Inspector for coordination and signature by the Chief of Engineering. No digging or excavation shall begin before the Chief of Engineering signs the AF Form 103. After the Chief of Engineering signs the AF Form 103, the Project Inspector will return it to the Contractor. Then, and only then, shall the Contractor commence excavation. The Contractor shall maintain all utility markings for the duration of the contract. Contractor shall maintain original version of the AF Form 103 for the duration of excavation work at the particular site. Ensure all applicable parties have coordinated on the form prior to excavation. For Miss Utility, use the Ticket Information Exchange (TIE) number or actual technician signature as evidence of coordination. The AF Form 103 clearance shall not be allowed to expire. The Contractor shall revalidate/resubmit the AF Form 103 within seven days prior to the expiration date if it is anticipated or known that the duration of excavation will exceed the 30-day limitation.

1.15.2 Miss Utility

Contractor shall contact Miss Utility (1-800-552-7001) at least 48 hours prior to excavation to identify non-Air Force-owned underground utilities (cable TV, Bell Atlantic and Virginia Power, etc.). Notices to Miss Utility are good for 15 working days; after that period, Contractor shall renew the notice. Indicate renewals on the AF Form 103 as applicable. Miss Utility is open 24 hours, seven days a week. Calls after 1700, before 0700, on weekends and on holidays are accepted for emergencies only. Holidays include: New Year's Day, Martin Luther King Day, President's Day, Memorial Day, Independence Day, Labor Day, Veteran's Day, Thanksgiving Day, Day after Thanksgiving and Christmas Day. After 48 hours, Contractor should contact Miss Utility to confirm that clearance/marketing operations have been completed. The Contractor must wait an additional 24 hours if any operators or contract locators have not responded to the Ticket Information Exchange (TIE) system request within the first 48 hours.

1.15.3 Markings

1.15.3.1 General Requirements for Marking Utilities

- a. Prior to commencing any excavation, the Contractor must inspect the site for clear evidence of unmarked facilities. If evidence of such facilities is present, the excavator must notify the notification center and wait an additional three hours for the facilities to be marked.
- b. The Contractor may choose to wait 72 hours and begin work after that time if there is no evidence that any underground facilities remain unmarked. However, it is recommended that Contractors contact the TIE system and confirm the status of underground facilities before they commence work.
- c. After the markings have been made, Contractors are required to maintain a minimum clearance of two feet between a marked, underground utility line and the cutting edge of any power-operated excavating equipment. If excavation is required within two feet of any marking, it shall be performed very carefully with hand tools in accordance with Virginia Code Section 56-265.24.
- d. If, during the course of excavation, a utility line has been exposed, before backfilling, the Contractor must inspect these

REPAIR AIRFIELD RAMP LIGHTS

facilities to ascertain if the facilities have been damaged. If damage of any kind is discovered or suspected, it is the Contractor's responsibility to immediately notify the utility owner directly. The Contractor must NOT attempt to repair damaged facilities.

e. Maintain any paint marks or stakes indicating underground utilities/lines as required during the duration of work or thirty calendar days from date of approved AF Form 103 (whichever is earlier). Note that Miss Utility clearance expires after fifteen working days.

1.16 OCCUPANCY AND SERVICES TO EXISTING FACILITIES

a. The Government will occupy all areas of the aprons and surrounding building except the immediate areas being altered by this contract. The Contractor shall not interrupt utilities serving these areas without coordinating with the Contracting Officer or his/her designated representative.

1.17 UTILITIES

All reasonable amounts of water and electricity required for this work will be made available to the Contractor if such utilities exist at the project site. Temporary lines, connections, installation, maintenance and removal shall be the Contractor's responsibility. The Contracting Officer, or the Contracting Officer's designated representative, shall approve any temporary lines and connections. All services are subject to discontinuance without notice to the Contractor in an emergency. Three-phase power may not be available. The Contractor shall provide his/her own necessary utilities when such utilities are not available at the project site.

1.18 UTILITY OUTAGES AND TRAFFIC

Contractor shall request utility/power outages and/or changes to normal traffic flow pattern 14 calendar days in advance of disruption or change to either.

1.19 CONVENIENCE FACILITIES

Existing restroom facilities may not be used by construction personnel. The Contractor shall maintain, in a neat and sanitary condition, such accommodations for the use of his employees. Temporary restroom facilities shall be white in color.

1.20 SUPERVISION

1.20.1 Working Supervisor

The Contractor shall designate an employee or employees to oversee work under this contract. This employee will be a working supervisor. While any work is being performed, the designated employee or employees shall remain at the job site, except for such incidental errands as required by his/her duties. The employee or employees are responsible for the proper coordination and timeliness of the work, and the proper workmanship of all trades; therefore, his/her absence from the project site shall be considered as damaging to the Government. The ability of his/her supervision, based on knowledge and experience, is essential to the proper

REPAIR AIRFIELD RAMP LIGHTS

execution of the work, as is the ability to communicate and direct the efforts of those performing the work. The Government reserves the right, in the event that it becomes apparent the employee or employees are not satisfactorily directing the work, to require the Contractor replace the employee or employees.

1.21 RECORD DRAWINGS

1.21.1 Record of Work Progress

During the progress of the work, the Contractor shall keep a careful record at the job site of all changes, corrections and deviations from the layouts and details shown on the drawings to include all contract modifications. The Contractor shall enter such changes on project drawings promptly, but not later than on a weekly basis. Such revised drawings shall be considered "redline" as-built drawings.

1.22 DELIVERABLES AND FINAL AS-BUILTS

1.22.1 Geodetic Control Surveys

The Contractor shall provide horizontal and vertical control surveys for the precise location of primary survey points for planning, engineering, construction, real estate projects, GIS applications or facility management.

1.22.2 Deliverable Requirements

a. The contractor shall use conventional surveying and other methods, such as a total station or Global Positioning Systems (GPS) for field data collection at an accuracy level in accordance with "Geospatial Positioning Accuracy Standards, Part 4: Architecture, Engineering, Construction, and Facilities Management," published by the Federal Geo-graphic Data Committee (FGDC), dated February 2002. This standards document can be found at:

http://www.fgdc.gov/standards/status/sub1_5.html.

b. All geospatial data shall overlay on the installation's most current orthorectified imagery provided by the government. The collected data will incorporate the coordinate and projection system of the imagery, NAD 83 Virginia State Plane South, NAVD 88, and have an external spatial reference (.prj) file attached that specifies the parameters of the coordinate system.

c. The contractor shall provide survey grade GPS data at an accuracy level of ± 2 cm. where appropriate (as determined by the Government), and all other collection at a resource grade accuracy level of $\pm < 0.5$ meter.

d. The contractor shall provide a quality control (QC) report that must state whether all inconsistencies in the data generated were corrected, or it must detail the remaining errors by case.

e. Data on the location of utility lines shall be captured at a minimum every 50 feet and each turn or bend in a utility line must also be captured.

f. The contractor shall prepare and submit a GIS .mdb that links the respective spatial and tabular databases through ESRI ArcGIS 9.1 The

REPAIR AIRFIELD RAMP LIGHTS

contractor shall utilize a topology build and clean routine and assure the following:

- o No erroneous overshoots, undershoots, dangles or intersections in the line work
- o Lines should all be continuous, i.e. do not create dashed lines with many small line segments
- o Point features should be digitized as points, not graticules, symbols or icons
- o No sliver polygons
- o All polygons completely close and have a single unique centroid
- o Digital representation of the common boundaries for all graphic features must be coincident, regardless of feature layer

g. Feature Attributes: The contractor shall identify the classification, type, location, ID number, and any other necessary attributes (specified by the Government) for all surveyed, mapped, designed or proposed features.

h. Entity naming conventions, attribute fields, and domain names will be collected in the format defined by the CADD/GIS Technology Center's Spatial Data Standards (SDS) release 2.3 (or the most current version available), except where modified by the government. This standards document can be found at:

<http://tsc.wes.army.mil/products/tssds-tsfms/tssds/projects/sds/>.

Metadata: The contractor shall complete all metadata elements marked mandatory and mandatory-if-applicable as defined by the FGDC Content Standards for Digital Geospatial Metadata for each feature layer collected. This standards document can be found at:

<http://www.fgdc.gov/metadata/contstan.html>.

i. Metadata must include an NSSDA accuracy statement at the 95% confidence interval & corresponding calculation worksheets as outlined in "Geospatial Positioning Accuracy Standards, Part 3: National Standard for Spatial Data Accuracy," published by the Federal Geographic Data Committee (FGDC). This standards documentation can be found at: http://www.fgdc.gov/standards/status/sub1_3.html

j. Metadata should be submitted in ESRI ArcGIS 9.x format and stored as an XML document with the corresponding feature layer.

1.22.3 Topographic and Infrastructure Surveys

The Contractor shall provide surveys to consist of, but are not limited to, field data acquisition of detailed topographic, planimetric and infrastructure feature data for use in engineering site planning, cost estimating, design, as-builts, and construction layouts.

1.22.4 Computer-Aided Drafting and Design (CADD) Digital Drawings

These deliverables include (but are not limited to): roof plans, interior designs or layouts, floor plans, blueprints, engineering drawings or details, architectural drawings or details, construction drawings or details, cross-sections, wall sections, stair details, elevations, and other schematics generally used in the design, repair, construction, or maintenance of Government installations.

- a. All CADD data deliverables shall be created or designed with the AutoCAD version 2007 (or latest version) drawing software.

REPAIR AIRFIELD RAMP LIGHTS

Drawings will be delivered in the AutoCAD ".DWG" file format as "stand alone" drawing files without separate reference files.

- b. The contractor shall use the A/E/C CADD Standard 2.0 (or latest version) when creating or revising any CADD data deliverables. These standards can be found or reviewed at:
<http://tsc.wes.army.mil/Products/standards/aec/intro.asp>.
- c. The Industry Standard model file and sheet naming conventions, consisting of a Discipline/Code Designator, Drawing Type Code, Sheet Type Code/Designator, and Sheet Sequence Identifier shall be used for all submissions - diagrams of this naming convention can be found in the A/E/C CADD Standard.
- d. All submittals should include any standards sheets (abbreviations, symbols, fonts, etc.) necessary for a complete project, and document any nonstandard fonts, tables, symbols, etc. that are used.
- e. All drawing files, unless otherwise specified, will use units of the English System.
- f. Acceptable drawing scales depend on the type of drawing and the size of area the drawing encompasses - A detailed description of which drawing scale to select can be found in the A/E/C CADD Standard Release 2.0 (or latest version).

1.22.5 Delivery Format

Note: No deviations from the Government's established standards will be permitted unless prior written approval of such deviation has been issued by the Government. All linkages of non-graphical data with graphic elements, relationships between data objects and attributes, and report formats shall be maintained.

These deliverables include, but are not limited to the following:

- a. Site plans
- b. As-built drawings
- c. Engineering designs, plans or surveys
- d. Topographic surveys or studies
- e. Boundary or Cadastral surveys
- f. Master Plan drawings
- g. Utility (water, sewer, power, storm, etc.) designs, plans, surveys and studies
- h. Pavement, Grading or Excavation plans
- i. Soil/Geology studies or surveys
- j. Environmental assessments, surveys, studies or plans
- k. Historical or Archaeological surveys, studies or plans

REPAIR AIRFIELD RAMP LIGHTS

All data deliverables shall be in a digital (electronic information) format and shall be delivered in a format that conforms to the CADD/GIS Technology Center's Spatial Data Standards version 2.4 (or latest version available) and A/E/C CAD Standards version 2.10 (or latest version available) as applicable. These standards documents and programs can be found at <http://tsc.wes.army.mil/products>. ALL digital files shall be delivered in a format that is directly readable and compatible with the installation's software and hardware platforms without conversion.

1.22.6 Setup Procedures for Deliverables

The following procedures must be performed before a file is placed on the delivery media:

- a. Include all files, both graphic and non-graphic, required for the project. Make sure all files are in the same directory, and that references to those files do not include device or directory specifications.
- b. Ensure all reference (external reference) files are merged into each drawing, NOT attached and, without device or directory specifications.
- c. Remove all extraneous graphics/text outside the project border area, and set the active parameters to a standard setting (or the setting contained in the seed or prototype file).
- d. Include any standards sheets (abbreviations, symbols libraries, font libraries, color tables, pen tables, plot configuration files, user command files, etc.) necessary for a complete project.
- e. Compress and/or reduce all files using the appropriate utilities. A digital media copy of the decompression utility should be provided with the delivered data.

1.22.7 Delivery Media

Acceptable Delivery Media

- a. CD-ROM or;
- b. DVD-ROM

AND one (1) set of as-built drawings on Mylar media at project completion.

CD-ROM is the preferred format due to its extended shelf life. Digital media must have an external label listing format and version of the operating system on which the media was created (e.g. Windows 2000), utility (command) used for writing the files to the media, a short description of contents, a sequence number if there are multiple volumes, and the date of CD creation.

A transmittal sheet must accompany the media containing the information included on the external labels, total number of volumes being delivered and a list of file names and file descriptions on each volume. The transmittal sheet must also include instructions for reading, restoring, or transferring the files from the media, and certification that all delivery

REPAIR AIRFIELD RAMP LIGHTS

media is free of known computer viruses - including the name(s) of the virus scanning software, date the virus scan was performed, virus definition pattern date of service and version.

1.22.8 Government Furnished Materials

The Government will provide the contractor with data and information concerning all necessary and pertinent functions and principal features of the identified project. These items will include:

- a. The installation's latest georeferenced digital planimetric data and/or base map in ESRI Arc/Info 8.x format, or best format available, with associated data files.
- b. The installation's most current orthorectified imagery and its geospatial parameters (coordinate system, datum, projection, distance units).
- c. Any pertinent and necessary prototype or seed files.
- d. Frequency settings for the Real-Time Kinematic (RTK) GPS Base Station and the preferred GPS receiver specifications.

Any other data or schematics deemed necessary for project completion, pending approval from the Government.

1.22.9 Government Review

The Government shall review the submitted data and documentation upon completion of all stated work. Missing or incomplete items will be documented and forwarded to the Contractor for completion. Upon receipt of a complete submittal, the Government will conduct a quality review and notify the contractor within fourteen calendar days of acceptance (along with any stipulations this includes) or rejection of the deliverables described herein. Failure to adhere to any of the stated delivery specifications could result in rejection of deliverables and nonpayment. Contractors should, at a minimum, submit data and documentation samples at 25% and 75% project completion to avoid the rejection of final deliverables.

1.22.9.1 Geo Integration Office Point of Contact

Any questions regarding data collection efforts, deliverable formats or deliverable specifications should be addressed to the Geo Integration Office, contact information:

Patricia McSherry
37 Sweeney Boulevard Room 224
Langley AFB, Virginia 23665
(757) 764-1164

1.22.10 As-Built Drawing Submittal

At the time of beneficial occupancy, the Contractor shall submit as-built data to the Contracting Officer, or his/her designated representative, incorporating the aforementioned information into the project drawings. The Contractor shall also ensure that a separate copy of all similar as-built data is provided for delivery to the Base GeoBase Office. The as-built deliverable (plans, shop drawings, surveys, studies, imagery, designs, manuals, spare parts lists, etc.) shall be in a digital

REPAIR AIRFIELD RAMP LIGHTS

(electronic information) format and shall be delivered on standard compact disks (minimum 650 megabytes) in a format that is directly compatible with the CADD/GIS Technology Center's Spatial Data Standards, Version 2.0 (or latest version available). No "redline" or marked-up drawings will be accepted as the final as-built drawings. The data provided shall be compatible with AutoCAD Map and shall be submitted by the Contractor to the Contracting Officer, to the Base GeoBase Office, and to the Engineering Support on three separate compact discs (CDs). In addition, one set of as-built drawings will be submitted to Engineering Support on Mylar media; as-builts on paper media will not be accepted.

1.23 WARRANTY OF CONSTRUCTION

- a. In addition to any other warranties in this contract, the Contractor warrants that work performed under this contract conforms to the contract requirements and is free of any defect in equipment, material or design furnished, or workmanship performed by the Contractor or any subcontractor or supplier at any tier. This warranty shall not limit the Government's rights under the Inspection and Acceptance clause of this contract with respect to latent defects, gross mistakes or fraud.
- b. This warranty shall continue for a period of one year from the date of final acceptance of the work. If the Government takes possession of any part of the work before final acceptance, this warranty shall continue for a period of one year from the date the Government takes possession. In the event the Contractor's warranty of this clause has expired, the Government may sue, at its expense, to enforce a subcontractor's, manufacturer's or supplier's warranty.
- c. The Contractor shall remedy, at the Contractor's expense, any failure to conform or any defect. In addition, the Contractor shall remedy, at the Contractor's expense, any damage to Government-owned or controlled real or personal property when that damage is the result of:
 1. The Contractor's failure to conform to contract requirements, or
 2. Any defect of equipment, material, workmanship or design furnished.
- d. The Contractor shall restore any work damaged in fulfilling the terms and conditions of this clause. The Contractor's warranty with respect to work repaired or replaced will run for one year from the date of repair or replacement.
- e. The Contracting Officer shall notify the Contractor, in writing, within a reasonable time after the discovery of any failure, defect or damage.
- f. If the Contractor fails to remedy any failure, defect or damage within a reasonable time after receipt of notice, the Government shall have the right to replace, repair or otherwise remedy the failure, defect or damage at the Contractor's expense.
- g. With respect to all warranties, express or implied, from subcontractors, manufacturers, or suppliers for work performed and materials furnished under this contract, the Contractor shall:
 1. Obtain all warranties that would be given in normal

REPAIR AIRFIELD RAMP LIGHTS

commercial practice, and

2. Require all warranties to be executed, in writing, for the benefit of the Government if directed by the Contracting Officer, and

3. Enforce all warranties for the benefit of the Government if directed by the Contracting Officer.

- h. Unless a defect is caused by the negligence of the Contractor, sub-contractor or suppliers at any tier, the Contractor shall not be liable for the repair of any defects of material or design furnished by the Government or for the repair of any damage that results from any defect in Government-furnished material or design.
- i. Defects in design or manufacture of equipment specified by the Government on a "brand name and model" basis shall not be included in this warranty. In this event, the Contractor shall require any subcontractors, manufacturers or suppliers thereof to execute their warranties, in writing, directly to the Government.
- j. The warranty enumerated herein does not preclude any manufacturer warranties in excess of one year as noted in the individual specifications sections. The Contractor should read each section carefully to ensure that he/she is aware of all warranties called for in this project.

1.24 WARRANTY/GUARANTEE RECORDS

1.24.1 Certification of Equipment

The Contractor shall prepare Optional Form(s) (OF) 274, Equipment Warranty Certificate, and affix the certificate(s) to all warranted components of the equipment installed during the project. When a complete mechanical system has been installed, affix the OF(s) 274 to the Mechanical Room door also. If the warranted items are in a new facility, Optional Form(s) 274 shall be placed as mentioned above. The Construction Inspector will distribute the OF 274 to the Contractor during the Pre-Construction Conference. The Contractor shall place all OF(s) 274 on the appropriate equipment prior to final acceptance of the project by the Government.

1.24.2 Listing of Equipment

The Contractor is required, prior to the final inspection to provide a listing of all equipment or material carrying a manufacturer's warranty or as indicated in the specifications. Use the following Equipment Warranty/Guarantee Record for each item and attach manufacturer's certificate as appropriate.

Equipment
Warranty / Guarantee Record

Facility No: _____ Project No: MUHJ _____

REPAIR AIRFIELD RAMP LIGHTS

Project Title: _____ Work Order: _____ Shop Code: _____

Item: _____ Location: _____ Contractor: _____

Prefix: _____ Suffix: _____ Serial No: _____ Model No: _____

Style: _____ HZ: _____ Volts: _____ HP: _____ Size: _____ Frame: _____

Purchase Cost: _____ Replacement Cost: _____ Manufacturer: _____

Date Purchased: _____ Date Installed: _____

Effective Date: _____ Expiration Date: _____

Replacement, New or Other: _____ Purchase Number: _____

GSA Contract Number: _____

Contract Inspector: _____ Phone: _____

Remarks: _____

Evaluator: _____ Grade: _____ Title: _____ Orgn: _____

1.25 SEASONAL HVAC REQUIREMENTS

Air conditioning systems are required to be operational from 15 May through 15 September and the heating systems are required to be operational from 15 October through 1 May. Provide temporary heating or cooling during these periods if the air conditioning system or heating system is shut down to perform any work. Submit shop drawings for approval of proposed method for providing temporary heating or cooling.

1.26 TIME EXTENSIONS FOR UNUSUALLY SEVERE WEATHER

This provision specifies the procedure for the determination of time extensions for unusually severe weather. The listing below defines the adverse weather days that are anticipated monthly. The listing is based upon data from the National Oceanographic & Atmospheric Administration (NOAA) or similar data.

MONTHLY ANTICIPATED ADVERSE WEATHER CALENDAR DAYS

JAN	FEB	MAR	APR	MAY	JUN	JUL	AUG	SEP	OCT	NOV	DEC
13	12	12	9	10	9	10	10	7	8	10	12

1.26.1 Base Line

The above schedule of anticipated adverse weather will constitute the base line for monthly (or portion thereof) weather time evaluations. Upon acknowledgment of the Notice To Proceed and continuing throughout the contract on a monthly basis, actual adverse weather days will be recorded on a calendar day basis (include weekends and holidays) and compared to the monthly anticipated adverse weather in the schedule above. The term "actual adverse weather days" shall include days impacted by actual adverse weather days.

REPAIR AIRFIELD RAMP LIGHTS

1.26.2 Calculation of Adverse Days

The number of actual adverse weather days shall be calculated chronologically from the first to the last day in each month. Once the number of actual adverse weather days anticipated in the schedule above have occurred, the Contracting Officer, or his/her designated representative, upon the Contractor's written request, will examine any subsequently occurring adverse weather days to determine whether the Contractor is entitled to a time extension. Before adverse weather entitlement is granted, the Contractor must demonstrate that fifty percent or more of his/her workdays were affected by the subsequent adverse weather. The adverse weather must also delay work critical to the timely completion of the project. The Contracting Officer, or his/her designated representative, will convert any delays meeting the above requirements to calendar days and issue a modification.

Note: For all weather dependent activities, the Contractor's schedule must reflect the anticipated adverse weather delays that are noted above.

1.26.3 Examples of Adverse Weather

The following is considered as adverse weather: Weather of a nature that workers cannot perform work as scheduled or get to work site (i.e. hurricane, tornado, high winds, floods, extremely cold weather, ice storm, sleet, heavy snow storm, et cetera).

1.27 FINAL INSPECTION AND ACCEPTANCE STANDARDS

1.27.1 Seeding

Within seven workdays of actual completion of work at contract site, the Contractor shall grade, rake, and seed (or sod), or prepare for seeding (or sodding). When areas of the site are raked prior to seeding (or sodding) or for level-ing of topsoil to rid the site of mounds, clods and / or ruts, the Contractor shall ensure that no clods larger than 1" are left on the site. Contractor shall restore the site to a condition and appearance similar or equal to existing before the damages occurred. Such restoration work will not be considered complete until approved by the CO or his/her designated representative. The Government will not accept sites that have not been raked and restored to this standard. **Straw shall not be used as a cover for newly sown seeds or freshly seeded areas.**

1.27.2 Removal of Signs and Barriers

All Contractors' stakes, traffic/safety cones and barriers, warning tape, erosion control fences, et cetera, that are erected during construction, shall be removed entirely prior to Government final acceptance of project.

1.27.3 Removal of Trailers and Storage Units

All trailers, equipment/storage units, residual construction materials shall be removed from construction site within five workdays after completion of work at that job site.

1.28 CONSTRUCTION DATA WORKSHEET

The Contractor is required, prior to the final inspection, to submit a completed copy of the following Construction Data Worksheet. This worksheet is used by the Air Force to inventory and capitalize new work.

REPAIR AIRFIELD RAMP LIGHTS

The Contractor shall complete only those areas of the form that are applicable to the work included in this project.

DD FORM 1354 CHECKLIST

1. General Building Data.

Exterior Dimensions: SF:(Main Bldg)
SF:(Wings)

REPAIR AIRFIELD RAMP LIGHTS

SF:(Offsets)

No of Stories:

Dimensions of Covered Walkways/Corridors:

Type of Construction:

Foundation:

Floors:

Exterior Walls:

Roof:

Utilities:

Water (Type and size of pipe):

Gas (Type and size of pipe):

Electric (Phase, voltage, wire):

Other Utility (Type, capacity, etc.):

2. Installed Systems & Plants.

<u>Category</u>	<u>Nomenclature</u>	<u>Unit</u>	<u>Quantity</u>	<u>Cost</u>
- Fire Protection.				
880-211	Closed Head Auto Sprinklers	SF/HD		
880-212	Open Head Deluge System	SF/HD		
880-216	Pre-action Sprinkler System	SF/HD		
880-217	AFFF PA Sprinkler System	SF/HD		
880-218	Hi-expansion Foam System	EA		

REPAIR AIRFIELD RAMP LIGHTS

880-221	Auto Fire Protection System	SF/EA
880-222	Manual Fire Alarm System	EA
880-231	CO2 Fire System	EA
880-232	Foam Fire System	EA
880-233	Other Fire System	EA
880-234	Halon 1301 Fire System	EA
880-235	Dry Chemical System	EA
880-236	Foam System	EA

- Security.

872-841	Security Alarm System	EA
---------	-----------------------	----

- Installed Plants.

890-124	A/C from Central Plant	SF
890-126	A/C Window Units	SF/TN
890-125	A/C Plant 100 Tons	TN
821-115	Heating Plant 750-3500 MBh	MB
821-116	Heating Plant Over 3500 MBh	MB
811-147	Emergency Power Generator	KW
124-xxx	Fuel Tank for Heating/Generator	GA

(Type of Fuel:)

3. Related Facilities.

116-xxx	Pads (Type:)	SY
411-xxx	Large Storage Tanks (Contents:)	BL
812-223	Pri Elec Distr	LF
	- Overhead	LF
	- Transformers	KVA
	- Power Poles	LF/EA
812-224	Sec Elec Distr	LF
812-225	Pri Elec Distr	LF
	- Underground	LF
	- Transformers	KVA
812-226	Sec Elec Distr	LF
812-926	Exterior Area Lighting (Street/Park)	EA
824-464	Gas Mains	LF
831-169	Sewage Septic Tank	KG
832-255	Industrial Waste Mains	LF

REPAIR AIRFIELD RAMP LIGHTS

832-266	Sanitary Sewer Mains	LF
841-161	Water Supply Mains	LF
842-245	Water Distr Mains	LF
843-315	Fire Hydrants	EA
851-143	Curbs & Gutters	LF
851-145	Driveway	SY
851-147	Road	SY/LF
852-262	Vehicle Parking	SY
852-289	Sidewalk	SY
871-183	Storm Drains	LF
872-247	Security Fence	LF
872-248	Interior Fence	LF
890-144	Compressed Air Distr	LF
890-158	Load/Unload Platform	SF
890-187	Utility Vault	SF
890-272	EMCS Field Equipment	EA
890-273	EMCS Data Links	LF
135-583	Telephone Duct	LF
135-586	Telephone Pole	LF

4. Additions to Existing Facilities.

Use checklists 1 - 3 above. Include any plants, systems, real property in-stalled equipment, or related facilities added, removed or replaced.

5. Alterations or Renovations to Existing Facilities.

Use checklists 1 - 3 above. Include plants, systems, real property installed equipment, or related facilities added, removed or replaced. If demolition of existing facilities was a part of the project, include the specifics and costs related to the demolition.

6. Remarks.

Where needed, add any explanatory remarks or descriptions, which more fully

REPAIR AIRFIELD RAMP LIGHTS

describe items.

7. When is a DD Form 1354 Required?

- Initial construction of a new facility
- Addition to an existing facility
- Demolition of an existing facility (and all its associated related real property)
- Removal of, or upgrade to, an installed system
- In general, if the project was funded in part or in whole with minor construction (EEIC 529) or MCP funds, a DD Form 1354 is required in order to transfer the completed construction to real property records

-- End of Section --

BLANK PAGE

REPAIR AIRFIELD RAMP LIGHTS

SECTION 01 12 00

ENVIRONMENTAL SPECIAL CONDITIONS

12/08

PART 1 ENVIRONMENTAL PROTECTION

All work is to be performed in a manner that prevents pollution, protects the environment, and conserves natural resources.

1.1 Submittals

Submit the following in accordance with Section 01 11 00 SPECIAL CONDITIONS, Paragraph 1.2:

SD-01 Preconstruction Submittals

Hazardous Waste Management Plan (AFI 32-7080)

Hazardous Material Worksheet for each item

SD-06 Reports

Construction/Demolition Debris Recycling Report

Trip Tickets

Contractor's Monthly HAZMAT Report

Comprehensive Affirmative Procurement Report

Recovered Materials Determination Form

1.2 WASTE DISPOSAL

1.2.1 SOLID WASTE DISPOSAL

1.2.1.1 Compliance With Regulations

All waste materials generated by any work under this contract performed on a Government installation shall be handled, transported, stored, recycled, and disposed of by the Contractor and by his/her subcontractors at any time in accordance with these specifications, all applicable Federal, state, or local laws, ordinances, regulations, court orders, or other types of rules or rulings having the same effect of law. These include but are not limited to the Resource Conservation and Recovery Act (RCRA) (40 CFR 260-270); Federal Water Pollution Control Act, as amended (33 USC Sec 1251 ET SEQ); The Clean Air Act, as amended (42 USC Sec 1857 ET SEQ); The Endangered Species Act, as amended (16 USC Sec 1531, ET SEQ); The Toxic Substances Control Act, as amended (15 USC Sec 2601, ET SEQ); The Solid Waste Disposal Act, as amended (42 USC 6901 ET SEQ); the Archaeological and Historic Preservation Act, as amended (16 USC Sec 469, ET SEQ), and the Virginia Solid Waste Management Regulations (9VAC 20-80).

The Contractor shall collect all solid wastes generated during the performance of the contract in a container/area provided by the contractor and approved by the Contracting Officer. The Contractor shall provide appropriate containers for the collection and segregation of solid wastes,

REPAIR AIRFIELD RAMP LIGHTS

recyclables, and C&D debris generated directly and indirectly by work under this Contract. The Contractor is prohibited from using base dumpsters or other government owned/leased waste receptacles for the disposal of any solid wastes. All solid wastes shall be reclaimed, recycled, or disposed of prior to completion of work on LAFB.

As proof of proper disposition of solid wastes, the Contractor shall provide legible weight receipts for solid waste disposed and materials recycled bearing the name, address, and phone number of the receiving facilities for every load of materials delivered. The weight ticket shall detail the type of material, weight of the material in pounds or tons, the date of the transaction, and a signature from a representative of the receiving facility. Receipts shall be submitted to the Contracting Officer within ten (10) calendar days after the transaction.

Under no circumstances will any solid waste or hazardous materials be left at LAFB at the end of the project. Before the project is turned over to the government, the contractor will remove all solid wastes and hazardous materials from the installation. Those items include but are not limited to dirt piles, concrete piles, asphalt piles, and rubbish piles. No materials will be left for the future use of the government UNLESS instructed to do so in writing by the government. This is to include the before mentioned items and also regular or touch-up paint, plaster, solvents, etc. If it is determined that the contractor left materials behind, services may be terminated and/or a penalty payment to include the cost of disposal of the material by the government may be withheld from the project payment.

NOTE: Hazardous materials are different from hazardous wastes so be careful not to confuse the two. For hazardous wastes, they will not be removed from the installation without the 1 CES Hazardous Waste Managers signing the Hazardous Waste Manifest. The LAFB Hazardous Waste Managers can be contacted at 757-764-1132/1133 if needed.

1.2.1.2 CONSTRUCTION/DEMOLITION DEBRIS DIVERSION

As good stewards of the environment, the government is committed to diverting its waste away from landfills to the greatest extent possible. This can be done through recycling, reusing (when directed by the government), and donating construction and demolition debris materials. The contractor shall recycle all construction/demolition debris to the maximum extent possible. The Contractor shall make every effort to recycle materials such as but not limited to concrete (including concrete with rebar), brick, asphalt, all metals, wood, roofing materials, wallboard, ceiling tiles, etc. With prior coordination through the CO and 1 CES/CEV, the contractor may take scrap metals to the Langley AFB scrap metal yard for recycling. The following are some suggested local sites for recycling construction and demolition debris:

Local Sources of Recycling

Company	Address	City	Phone	Acceptable Items
Tidewater Fibre	5602 Chestnut Avenue	Newport News	247-5766	Paper, cardboard, plastics, aluminum, glass, tin cans
Old Dominion Recycling	1618 W. Pembroke Ave	Hampton	723-2942	Aluminum, copper, steel, iron, metals, paper, tires

REPAIR AIRFIELD RAMP LIGHTS

Butler Paper	324 Newport St	Suffolk	539-2351	Industrial & Commercial Paper Recycling
Dubin Metals	2409 Bowdens Ferry Rd	Norfolk	622-3970	Scrap metals, copper, brass, batteries, radiators, aluminum
Gutterman Iron & Metal	1206 E. Brambleton	Norfolk	627-1095	Scrap brass, copper & aluminum
Sims Metal	2116 George Washington Memorial Hwy	Tabb	599-4940	Steel, aluminum, brass, copper, stainless steel, radiators
Waterway Marine Terminal	1401 Precon Drive	Chesapeake	333-3427	All C&D materials i.e. concrete, concrete w/rebar, lumber, asphalt
Waterway Materials Corp	1401 Precon Drive	Chesapeake	545-0004	Concrete, concrete w/rebar, brick, block, asphalt
K.F. Wilson	2972 N. Armistead Ave	Hampton	865-7182	All C&D materials i.e. concrete, concrete w/rebar, lumber, asphalt
CrushCon Aggregates	100 North Park Lane	Hampton	723-1131	Concrete, concrete w/rebar

1.2.1.3 RECYCLING AND DISPOSAL REPORTING

The Contractor shall report on a quarterly basis the tonnage of the items recycled and the amounts disposed of by landfill and amounts disposed of by regular or waste-to-energy incineration to the project manager, the Contracting Officer, and 1 CES Environmental Flight (1 CES/CEVQP) by the 5th day of each quarter (Jan, Apr, Jul, Oct) during the period of performance. This report will be for the previous quarter. The report shall list the title of the project, the project number, the Contractor's company name and point-of-contact, phone number, the type items (i.e. concrete, concrete with rebar, asphalt, brick, scrap metals, wood, wallboard, etc) and the tonnage of those items recycled. For all items that could not be recycled, the contractor will provide a brief reason as to why the items could not be recycled.

For items disposed of, one total tonnage can be given for items landfilled and one total tonnage for items incinerated (specify waste incinerator or waste-to-energy incinerator) instead of reporting disposal figures for the various items. For items that cannot be accurately measured, estimates will be sufficient. Use the form at Attachment 1 to report this information to the Contracting Officer, project manager, and to 1 CES/CEVQP.

To send it to 1 CES/CEVQP, email it to 1CES.CEV@langley.af.mil or mail it to:

1 CES/CEVQP
 Attn: Pollution Prevention Mgr
 Bldg 328, Room 253
 37 Sweeney Blvd
 Langley AFB VA 23665

1.2.1.4 Contain Loose Debris

Loose debris on trucks leaving the site shall be loaded in a manner that shall prevent dropping of materials on streets and conform to local

REPAIR AIRFIELD RAMP LIGHTS

ordinances/laws. Fasten a suitable cover, such as a tarpaulin, over the load before entering surrounding streets.

1.2.1.5 Trip Tickets

Contractor shall submit all trip tickets from the landfill facility, incinerators, and recycling companies to show all debris is being landfilled, incinerated, or recycled in accordance with all Federal requirements and in an approved location. These trip tickets will be submitted to the Contracting Officer who will in turn give them to the project manager.

1.2.2 PETROLEUM CONTAMINATED WASTE

1.2.2.1 Contaminated Absorbents

All petroleum spills must be cleaned up using absorbent materials. Spills caused by the contractor will be the contractor's responsibility to containerize and dispose of the contaminated absorbent material. Spills caused by the government will be the responsibility of the government. Contact the base hazardous waste contractor Chugach at 225-5808 or 225-5809 to arrange for pick-up.

1.2.2.2 Waste Soil

Suspect soil must be tested to determine if it contains any contaminants prior to relocating it. Testing and disposal of soil shall follow Virginia Solid Waste Management Regulations 9VAC-20-80-700 (soil contaminated with petroleum products). Testing shall include: Total Petroleum Hydrocarbon (TPH), Total Organic Halogens (TOX), Benzene, Toluene, Ethyl Benzene, and Xylene (BTEX), and Toxicity Characteristic Leaching Procedures (TCLP). If test results determine "other than clean", the material will have to be transported to an appropriate landfill or processing center based on the contaminants identified. Contaminated soils, in sludge or slurry form, shall be containerized and managed as either hazardous waste or non-regulated waste, depending on what contaminate was spilled. The containerized contaminated soil shall be the responsibility of the contractor to dispose of such. CEV must review the sample results and sign all hazardous/non hazardous waste manifests prior to disposal. Contact 1 CES/CEVC Hazardous Waste Program Managers for additional information.

NOTE: UNDER NO CIRCUMSTANCES will soil, clean or contaminated, from Langley AFB be delivered to or donated to off-base sources (other than an appropriate landfill or processing center based on the contaminants identified) for use. Soils donated to off-base entities for use will be the sole liability and responsibility of the contractor.

1.2.3 UNIVERSAL WASTE

1.2.3.1 Fluorescent Lamps

The contractor shall use environmentally-friendly green tip fluorescent lamps during lamp replacement. Upon removal of old Sylvania lamps and high intensity bulbs, the contractor will box the lamps and manage them as universal waste. Other lamps (i.e. GE and Phillips) may be disposed directly in to regular trash. Contact the base hazardous waste contractor at 225-5808 or 225-5809 to arrange for pick-up, except in cases where lamp replacement is part of the contract. Lamps will be properly disposed of by the contractor with waste manifest being signed by 1 CES/CEVC Hazardous

REPAIR AIRFIELD RAMP LIGHTS

Waste Program Managers.

1.2.4 HAZARDOUS WASTE

1.2.4.1 SITE MANAGEMENT

All material containers must be closed when not in use. Materials are to be covered as protection from weather. Each container is to be properly labeled. Do not store hazardous materials near storm drains. Upon completion of this project the contractor shall remove all hazardous materials and hazardous waste (for associated manifest requirements see paragraph 1.1.4.2.)

1.2.4.2 MANIFESTS

1 CES/CEVC will review all lab analysis or MSDS of wastes prior to signing manifests. All hazardous waste manifests must be signed by 1 CES/CEVC prior to removal of such waste from the base. The generator copy of the manifest must be returned to 1 CES/CEVC, 37 Sweeney Blvd, LAFB VA 23665.

1.3 FUEL, SEWAGE, AND OTHER SPILLS

In the event of a fuel, sewage, and other toxic spillage during the performance of this contract, the Contractor shall be responsible for its containment, clean up, and related disposal costs and will notify 1 CES/CEVC immediately. The operator shall have sufficient spill response supplies readily available on the pumping vehicle and/or at the site to contain any spillage. In the event of a Contractor-related release, the Contractor shall immediately notify the Environmental Management Office and the Contracting Officer and take appropriate actions to correct its cause and prevent future occurrences. If the federal, state, or local authorities assess any monetary fine, penalty, or assessment related to the release of any substance by the Contractor, his/her employees, or agents during the performance of this contract, the Contractor shall be solely liable for its payment, authorizes the United States Air Force to withhold such from payment and otherwise indemnify and hold the United States Air Force harmless.

1.4 ASBESTOS OR LEAD BASED PAINT

1.4.1 ASBESTOS PRESENCE

No asbestos testing has been performed in the areas affected by this work. If asbestos is exposed, the Contractor shall cease work in the affected area and notify the Contracting Officer.

1.4.2 LEAD BASED PAINT PRESENCE

No lead based paint testing has been performed in the areas affected by this work. If lead based paint is exposed, the Contractor shall cease work in the affected area and notify the Contracting Officer.

1.5 AIR QUALITY

1.5.1 VOLATILE ORGANIC COMPOUNDS

All coatings and solvents used in the performance of this contract shall meet the required performance specifications and shall not exceed the volatile organic compound limits of the Air Pollution Control Districts

REPAIR AIRFIELD RAMP LIGHTS

where they are used.

1.5.2 DUST

Mitigation of fugitive dust emissions shall be accomplished in accordance with 9 VAC5-40-90, Standards for Fugitive Dust/Emissions.

1.5.3 GENERATORS

To meet permit requirements, submit required data (Kilowatt (KW) rating) for each emergency generator installed to 1 CES/CEVC.

1.5.4 OZONE DEPLETING SUSTANCES (ODS)

Contracts may not include any specification, standard, drawing, or other document that requires the use of a Class I ODS in the design, manufacture, test, operation or maintenance of any system, subsystem, item, component, or process. Contracts may not require the delivery of any items of supply that contains a Class I ODS or any service that includes the use of a Class I ODS.

1.6 WATER QUALITY

1.6.1 Erosion and Sediment Control

All construction operations shall comply with the requirements of the Virginia Erosion and Sediment Control Act. An Erosion and Sediment Control Plan shall be prepared prior to initiating groundbreaking activities. A copy of the E&SC Plan shall be forwarded to 1 CES/CEVC (Water Program Manager). Hay bales shall not be used for erosion control and inlet protection from storm water run-off. The Contractor shall submit alternate methods of protection to the Contracting Officer at the preconstruction conference for review and approval. The Contracting Officer will notify the Contractor of his/her decision prior to issuance of Notice to Proceed (NTP).

1.6.2 Stormwater Permit

If over one (1) acre is to be disturbed as part of the project, the contractor shall obtain a Stormwater General Construction Permit from the Virginia Department of Conservation and Recreation (VDCR). A stormwater pollution prevention plan (SWPPP) shall be prepared to support the stormwater permit; a copy of the SWPPP shall also be forwarded to 1 CES/CEVC (Water Program Manager). The contractor is solely responsible for obtaining, funding, and complying with the terms of the permit. A copy of the permit shall be forwarded to 1 CES/CEVC (Water Program Manager).

1.7 HAZARDOUS MATERIALS MANAGEMENT

1.7.1 Hazardous Materials Usage and Reporting

In compliance with AFI 32-7086 dated 1 Nov 2004 and AFI 32-7086 ACC Sup 1, all contractors are required to report the usage of all hazardous materials to the government for all projects and contracts including service contracts executed on LAFB. In accordance with FAR Clause 52.223-3, each offeror (Contractor) must provide the Contracting Office with a list of proposed HAZMAT that it plans to use on the installation during the performance of the contract. In accordance with AFFARS Clause 5352.223-9303, contractors must obtain Air Force authorization prior to

REPAIR AIRFIELD RAMP LIGHTS

using HAZMAT on an Air Force installation, and must report usage data to the HAZMART.

Hazardous materials are any substance defined by OSHA as a hazardous substance requiring a Material Safety Data Sheet (MSDS). Hazardous materials that need to be reported include but are not limited to chemicals, paints, thinners, sealing compounds, strippers, glues, solvents, all petroleum products including oils, hydraulic fluids, and fuels stored on-site (fuels in vehicles are exempt), pesticides, adhesives, acids, flammables, corrosives, oxidizers, compressed gases (such as but not limited to oxygen, acetylene, propane, flammable and non-flammable gases), all aerosols, and all materials containing hazardous substances.

The contractor shall request the proposed usage of all Hazardous Materials by completing the "Contractor Hazardous Material Worksheet" at attachment 2 for each hazardous material and shall submit a copy of the Material Safety Data Sheet (MSDS) for each item to the Contracting Officer (CO) prior to bringing the items on the installation. The Contractor shall submit to the CO the information for each item within 10 days after award of the contract or project and/or not less than fourteen calendar days prior to bringing the items on the installation. For short notice contracts or projects, the contractor will submit this information to the CO as soon as possible. An electronic version of the Contractor Hazardous Material Worksheet can be obtained through the project manager or 1 CES/CEVQP.

The CO will immediately provide this information to the project manager who will in turn provide it to 1 CES/CEVQP immediately.

After the project starts, monthly usage information will be provided to the CO who will in turn provide this information to the project manager who will in turn provide it to 1 CES/CEVQP. The form at Attachment 3 will be used to report monthly usage. For contracts/projects exceeding six months, this form is required to be filled out on a monthly basis. For contracts less than six months, this form is required at the beginning and at the completion of work.

If there are any questions on how to fill out the Contractor Hazardous Material Worksheet or the monthly report, contact the LAFB HAZMART at 757-764-3837 Monday thru Friday between the hours of 0730-1630 or visit them at:

1 LRS/HAZMART
Bldg 330
23 Sweeney Blvd
Langley AFB VA 23665

1.7.2 Hazardous Materials Management Process (HMMP)

The LAFB HMMP team will meet on a weekly basis or an as-needed basis to review the Contractor Hazardous Material Worksheets and MSDSs to ensure there are no concerns with the chemicals being used and/or stored on the installation. If there are concerns about any chemicals and if it is determined that the contractor plans to use an extremely hazardous chemical on LAFB, the HMMP team will notify the project manager and the Contracting Officer (CO) who will in-turn notify the contractor of LAFB's concern. The contractor will not bring any extremely hazardous chemicals on LAFB or any other chemicals that the HMMP team determines cannot be used on Langley. The HMMP team will also notify the project manager if all hazardous materials are authorized for use.

REPAIR AIRFIELD RAMP LIGHTS

If the contractor requires additional hazardous materials not previously submitted for approval, they shall submit the request as stated above seven days prior to bringing the item on the base.

NOTE: If it is determined at any time that hazardous materials are on site that were not reported in advance, the CO will be notified and the project can be stopped until the materials are submitted as stated above.

1.7.3 Hazardous Material Storage

Hazardous materials will be managed properly at all times while on LAFB. This means containers will be in good condition and will be properly labeled with the contents and hazard class (flammable, corrosive, oxidizer, etc) at all times. Containers will be closed at all times when not in use, hazardous materials will be kept under cover to protect them from the elements and to prevent stormwater runoff contamination, and tanks and 55-gallon liquid drums will have secondary containment. Gas cylinders will be maintained in the upright position with caps on and will be secured with chains and locks to prevent tampering and to prevent them from falling over. Gas storage areas will have signs indicating what type gases are stored in the area (ie flammable, oxidizer, non-flammable, etc). NO SMOKING signs will be posted in all hazardous materials storage areas. In addition, all hazardous materials will be segregated in storage according to compatibility (ie flammables will not be stored with corrosives, corrosives will not be stored with oxidizers, flammable gases will not be stored with flammable liquids, etc). LAFB is subject to inspections at any time from outside agencies (EPA, Virginia Dept of Environmental Quality, and OSHA) and any violations by the contractor will be the responsibility of the contractor and any fines associated with the violations will be resolved at the contractor's expense.

1.8 USE OF RECYCLED-CONTENT PRODUCTS: (GREEN PROCUREMENT)

Whenever the potential for use of non-recycled content products exists during the construction stage of the project, the Contractor shall incorporate in this project, as a substitute, recycled-content products that are listed and identified in the Environmental Protection Agency (EPA) Comprehensive Procurement Guidelines (CPG) for recycled-content products. The Contractor shall use recycled-content products as required by EPA and other governmental agencies and Federal Acquisition Regulation (FAR) clauses.

It is mandated by Executive Order 13101 (Greening the Government through Waste Prevention, Recycling, and Federal Acquisition) and Section 6002 of the Resource Conservation and Recovery Act (RCRA) that the Federal Government use recycled-content products in the construction and/or renovation of facilities. It is the intent of the Government to comply with the Environmental Protection Agency (EPA) requirement 100% of the time and use as many of the applicable listed recycled-content products as feasible and economically practical. The Contractor shall consider this a standard requirement for all aspects of the project construction.

The recycled-content products listed in the CPG can be found in the EPA website at www.epa.gov/cpg/products.htm. These products are also listed at Attachment 4. This list is subject to change at any time so it is the Contractor's responsibility to be aware of any updates or additions.

Such products shall also comply with the requirements of the EPA Recovered

REPAIR AIRFIELD RAMP LIGHTS

Materials Advisory Notice (RMAN). The RMANs recommend recycled-content ranges for CPG products based on current information on commercially available recycled-content products. The recommended recovered materials content percentage can be obtained by clicking on the product on the website.

1.8.1 Green Procurement Forms

Before starting the project, the Contractor shall complete attachment 4 indicating the items he plans to use. The Contractor will provide this to the Contracting Officer and the project manager. Then during the accomplishment of the project construction, the Contractor shall complete the form again. At this time, the Contractor shall indicate the use and non-use of products that are contained in the CPG and will list the recycled-content percentage for the applicable item. In each instance where a recycled-content construction product is not used, the Contractor shall provide to the Contracting Officer (or his/her designated representative) and the project manager a completed Exemption Form, attachment 5, "Recovered Materials Determination Form".

The Contractor shall complete this form for all items for which he or she desires an exemption from the Green Procurement Program for Recovered Materials that are being procured. Exemptions can only be taken if (1) the item is not available within a reasonable period of time (2) item fails to meet a performance standard in the specifications and (3) the item was only available at an unreasonable price i.e., the recycled-content product costs more than the non-recycled content product. The fourth reason on the Recovered Materials Determination Form, (4) the item is not available from 2 or more sources, does not apply to construction/renovation contractors as the Government will not specify where you can get your materials from. Specific reasons why an exemption is taken will be specified on the form and documentation supporting this reason will be provided and attached.

The Contractor will sign the form as the "Procurement Originator" and the completed form will also be signed by the 1 CES Engineering Flight Chief or Deputy Flight Chief. These forms will be kept in the project folder indefinitely.

1.9 ENVIRONMENTAL RESTORATION PROGRAM (ERP) ERQUIREMENTS:

1.9.1 Contaminated Soil and Free Product

Any material (soil) that is suspected of containing petroleum products shall be reported to the Contracting Officer or his/her designated representative. If discovered, the Contractor shall mitigate any potential threat to the workers, public and environment. The area that will be disturbed under this contract has the potential to have free product migrate into and under the construction site. Comply with VR-680 and record the quantity of any fuel removed from the line. Contaminated soil and/or free product shall not be used for backfill or removed from the base without written approval from the Contracting Officer. Once removal is approved, Contractor shall dispose of material under guidance of the Hazardous Waste Managers (1 CES/CEV). All hazardous waste manifests shall be prepared by the Contractor and shall be coordinated, approved and signed by 1 CES/CEVC Hazardous Waste Manager (37 Sweeney Blvd) prior to removal of such waste from the base.

REPAIR AIRFIELD RAMP LIGHTS

1.9.2 Site Safety

Site summaries from our Management Action Plan are furnished with this contract to familiarize personnel with the potential hazards associated with construction and demolition work at these sites. Ensure workers are informed of potential hazardous exposures from working at these sites, and that the appropriate precautions are followed to minimize hazards to human health and the environment. Personnel working at these sites shall have 40-hour HAZWOPER Training. At least one individual on site should have completed the OSHA 8-hour supervisor training course. The plans identify the boundary of these IPR sites. To perform work at these sites, the Contractor must have a Health and Safety Plan and Hazardous Waste Disposal Plan for proper disposal of all regulated materials generated during execution of this project.

1.9.3 Monitoring Wells

There may be several monitoring wells installed in and around the proposed construction area. Site maps and construction drawings provide the location of these wells. The Contractor shall take all precautions to prevent any damage to wells. If the wells and associated structures are damaged during the project, the Contractor shall repair/replace all damages at no additional expense to the Government. Contractor shall dispose of all regulated materials during repair of the damaged structures and remove any free product as required by VDEQ regulations.

1.9.4 Additional Excavation

Prior to any excavation beyond the immediate area or boundary of the construction site, the Contractor shall coordinate with 1 CES/CEV and obtain the Contracting Officer's approval.

1.10 SOIL SUPPORT PROGRAM (SSP) ACCEPTABILITY

The soils obtained from off-base sources shall meet the criteria outlined below. The soils generated during construction project excavation will be collectively referred to as project (soil) media. Soil media is not inherently waste-like, but it may contain waste-like materials, including contaminants associated with the site. Given the base history of operations, the contractor must make a determination of whether the soil is contaminated. If the media is determined to be contaminated, then a hazardous waste determination must be made. Standards for testing are described below. The contaminated media will be managed as a solid waste and removed from base. If the media is determined to be uncontaminated and not waste-like, then it may be disposed on site in an environmentally sound manner.

1.10.1 Clean Soil

Projects requiring clean soil, including but not limited to top soil and backfill materials, to be brought onto Langley AFB or relocated within base property must meet minimum standards based on results of physical (geotechnical) and chemical testing. All materials will meet physical (geotechnical) specifications appropriate for the type of project being accomplished and are typically identified elsewhere in the project specifications. The intent of this section is to prevent contamination from borrowed sources (i.e. planned excavation) and define clean soil based on chemical specifications. Levels of chemical contamination will be determined to ensure borrow soils may be used for the current and future

REPAIR AIRFIELD RAMP LIGHTS

use of the project location. The contractor shall implement a plan and confirm the proposed borrow soils meet clean soil requirements. The plan should incorporate borrow source information, sampling data, and testing results.

1.10.2 Borrow Source

The contractor shall provide detailed borrow source information (e.g., location, owner, operator, past and current land use, previous chemical testing results) at the point of planned excavation to 1 CES/CEV to determine chemical testing requirements. The contractor shall also submit a certification stating the materials contain no asbestos, no gross contamination have been discerned by visual or olfactory observations, and no spills of a listed hazardous waste (40 CFR 261) have occurred at the borrow site. If previous chemical testing results exist and are provided, 1 CES/CEV will evaluate those results to determine if they are sufficient and the proposed borrow soils meet clean soil requirements. If testing is incomplete, 1 CES/CEV will review borrow source information to determine chemical sample requirements.

1.10.2.1 On-base Soil Sources

Unless otherwise provided in the contract, the contractor shall bear all expenses of developing the source. For the site where soil is reclaimed from government land, the contractor may be required to perform final grade and seeding according to project requirements.

1.10.2.2 Excess Soil Work

Acceptable excess soil shall be delivered to the designated location(s) following approved haul routes. For the site where excess soil is deposited on government land, the contractor may be required to perform final grade and seeding according to project requirements.

1.10.3 Sample Plan

At least one composite sample (6-8 grabs) for each undisturbed borrow source would be taken from the original point of excavation and required for each 5,000 CY of soil. For soil taken from disturbed borrow sources, samples are required for each 1,000 CY of soil. The nature of the borrow source is to be considered when determining the quantity and depth of the samples. Additional samples may be required to adequately characterize the proposed borrow source (i.e. laterally and vertically). The contractor shall submit a Sample Plan (to include site map, excavation area, location and depth of samples) for 1 CES/CEV review and approval.

1.10.4 Chemical Testing Standards

The analysis must be performed by a laboratory approved by the U.S. Environmental Protection Agency. Submit a copy of the chain of custody and complete validated report of analysis to 1 CES/CEV for review and approval 30-days prior to use of any borrow soils. Chemical testing of any borrow source will include sampling for the following suite of contaminants (test requirements may be reduced based on borrow source information):

- Total Petroleum Hydrocarbons (TPH) to include Gasoline Range Organics (GRO) and Diesel Range Organics (DRO);
- Volatile Organic Compounds (VOCs) to include Benzene, Toluene, Ethylbenzene, and Xylene (BTEX);

REPAIR AIRFIELD RAMP LIGHTS

The soil support test suite shall also include unless generator knowledge suggests otherwise:

- Semi-volatile Organic Compounds (SVOCs);
- Pesticides;
- Polychlorinated Biphenyls (PCBs); and
- Target Analyte List (TAL) metals (including Mercury)
- Volatile Organic Compounds (VOCs) other than BTEX compound reference in the preceding paragraph.

1.10.5 Clean Soil Determination

Soils testing under the EPA screening levels and/or base "background" levels will be considered acceptable "clean" soil. Generally, acceptable clean soil must not exceed EPA Region III "Residential" Risk Based Concentrations (RBC) and the LAFB Upper Tolerance Limit (UTL) background soil concentrations. For use in current and future industrial areas, EPA Region III "Industrial" RBCs may be considered but shall not exceed UTL background levels.

1.10.6 Excavation and Delivery Screening

Common to any multiple point sampling, composite testing may not accurately characterize the entire site. Should contamination be detected (e.g. free product, stained soils, chemical odors) during excavation or delivery, soil operations shall be immediately discontinued pending 1 CES/CEV notification and resolution. Additional soil testing and screening may be required to determine if continued use of the borrow site is acceptable.

1.10.7 Material Physical Characteristics

All soil obtained from sources within or outside the limits of government-controlled land shall meet the physical characteristics as defined in project specifications.

1.11 TREE PROTECTION, PRESERVATION, AND PLANTING

1.11.1 Tree Protection

Trees take generations to mature, yet they can be irreparably damaged or killed within seconds, or subjected to conditions which may take five (5) to ten (10) years to kill them. Improper planting may result in short-term death, structural failure, or a long-term senescence. Most situations can be prevented.

Because trees contribute so much to our quality of life and because they can be a potential liability, they must be actively conserved, wisely selected, well placed, well planted, routinely maintained, and constantly protected. One of the most critical steps in planning for trees and cost effective ways of managing trees is to maintain adequate growing space for each tree's roots, trunk, and crown throughout the tree's life. Remember that as a tree gets older it gets larger and the growing space it requires increases accordingly.

For existing trees, there is a minimum amount of area, above (for the trunk and crown) and below ground (for soil health and the root system) that is required to protect trees and preserve tree health. This area has been identified as the critical root zone (CRZ) or tree protection zone (TPZ) by

REPAIR AIRFIELD RAMP LIGHTS

various experts and is generally agreed to be equivalent to the soil area below ground and the space above ground defined by the tree's dripline, or the greatest extent of the branches. This is depicted in Figure 1

However, for small trees, newly planted trees, and trees with narrow crowns, the dripline defines an area that is too small for proper protection. So it is best to define both the critical root and tree protection zones as the circular area above and below ground with a radius equivalent to the greater of 6 feet or 1.5 feet for every inch in trunk diameter at 4.5 feet above the ground. For example, a tree with a trunk diameter (dbh) of 20 inches has a CRZ and TPZ of 30 feet (20 inches x 1.5) around the tree. While the radius of the CRZ (and TPZ) is 30 feet, the diameter of the entire CRZ (and TPZ) is 60 feet.

Tree Protection Zone Structures

- Chainlink fence - 48-inch minimum height
- Snow/Sand fence - 48-inch minimum height
- Safety fence - 48-inch minimum height

1.12 DISCREPANCIES

In case of a conflict or discrepancy between environmental regulations or laws and the contract specifications, the Contractor shall immediately submit the matter in writing to the Contracting Officer for a determination. Without such determination any actions taken shall be at the Contractor's own risk and expense.

PART 2 PRODUCTS - NOT USED.

PART 3 EXECUTION - NOT USED.

-- End of Section --

BLANK PAGE

SECTION 01 35 26

GOVERNMENTAL SAFETY REQUIREMENTS

02/09

PART 1 GENERAL

1.1 REFERENCES

The publications listed below form a part of this specification to the extent referenced. The publications are referred to within the text by the basic designation only.

AMERICAN SOCIETY OF SAFETY ENGINEERS (ASSE/SAFE)

- | | |
|------------------|--|
| ASSE/SAFE A10.32 | (2004) Fall Protection |
| ASSE/SAFE A10.34 | (2001; R 2005) Protection of the Public on or Adjacent to Construction Sites |
| ASSE/SAFE Z359.1 | (2007) Safety Requirements for Personal Fall Arrest Systems, Subsystems and Components |

ASME INTERNATIONAL (ASME)

- | | |
|-------------|--|
| ASME B30.22 | (2005) Articulating Boom Cranes |
| ASME B30.3 | (2004) Construction Tower Cranes |
| ASME B30.5 | (2007) Mobile and Locomotive Cranes |
| ASME B30.8 | (2004) Floating Cranes and Floating Derricks |

NATIONAL AERONAUTICS AND SPACE ADMINISTRATION (NASA)

- | | |
|------------------|--|
| NASA NPG 8621.1 | (2004a) NASA Mishap Reporting, Investigating and Record Keeping Policy |
| NASA NPG 8715.3 | (2004) NASA Safety Manual |
| NASA NSS 1740.12 | (1993) NASA Safety Standard For Explosives, Propellants and Pyrotechnics |

NATIONAL FIRE PROTECTION ASSOCIATION (NFPA)

- | | |
|----------|--|
| NFPA 10 | (2007; Errata 2007; AMD 1 2007) Standard for Portable Fire Extinguishers |
| NFPA 241 | (2004) Safeguarding Construction, Alteration, and Demolition Operations |
| NFPA 70 | (2007; AMD 1 2008) National Electrical Code - 2008 Edition |
| NFPA 70E | (2008) Electrical Safety in the Workplace |

REPAIR AIRFIELD RAMP LIGHTS

U.S. ARMY CORPS OF ENGINEERS (USACE)

EM 385-1-1 (2008) Safety and Health Requirements Manual

U.S. NATIONAL ARCHIVES AND RECORDS ADMINISTRATION (NARA)

29 CFR 1910 Occupational Safety and Health Standards

29 CFR 1910.146 Permit-required Confined Spaces

29 CFR 1915 Confined and Enclosed Spaces and Other Dangerous Atmospheres in Shipyard Employment

29 CFR 1926 Safety and Health Regulations for Construction

29 CFR 1926.500 Fall Protection

1.2 SUBMITTALS

Submit the following in accordance with Section 01 11 00 SPECIAL CONDITIONS, Paragraph 1.2:

SD-01 Preconstruction Submittals

Accident Prevention Plan (APP)

Activity Hazard Analysis (AHA)

Crane Critical Lift Plan

Proof of qualification for Crane Operators

SD-06 Test Reports

Reports

Submit reports as their incidence occurs, in accordance with the requirements of the paragraph entitled, "Reports."

Accident Reports

Monthly Exposure Reports

Crane Reports

SD-07 Certificates

Confined Space Entry Permit

Hot work permit

License Certificates

Contractor Safety Self-Evaluation Checklist; G, A

REPAIR AIRFIELD RAMP LIGHTS

Certificate of Compliance (Crane)

Submit one copy of each permit/certificate attached to each Daily Quality Control Report.

1.3 DEFINITIONS

- a. Competent Person for Fall Protection. A person who is capable of identifying hazardous or dangerous conditions in the personal fall arrest system or any component thereof, as well as their application and use with related equipment, and has the authority to take prompt corrective measures to eliminate the hazards of falling.
- b. High Visibility Accident. Any mishap which may generate publicity and/or high visibility.
- c. Medical Treatment. Treatment administered by a physician or by registered professional personnel under the standing orders of a physician. Medical treatment does not include first aid treatment even through provided by a physician or registered personnel.
- d. Operating Envelope. The area surrounding any crane. Inside this "envelope" is the crane, the operator, riggers and crane walkers, rigging gear between the hook and the load, the load and the crane's supporting structure (ground, rail, etc.).
- e. Qualified Person for Fall Protection. A person with a recognized degree or professional certificate, and with extensive knowledge, training and experience in the field of fall protection; who is capable of performing design, analysis, and evaluation of fall protection systems and equipment.
- f. Recordable Injuries or Illnesses. Any work-related injury or illness that results in:
 - (1) Death, regardless of the time between the injury and death, or the length of the illness;
 - (2) Days away from work (any time lost after day of injury/illness onset);
 - (3) Restricted work;
 - (4) Transfer to another job;
 - (5) Medical treatment beyond first aid;
 - (6) Loss of consciousness; or
 - (7) A significant injury or illness diagnosed by a physician or other licensed health care professional, even if it did not result in (1) through (6) above.
- g. "USACE" property and equipment specified in USACE EM 385-1-1 should be interpreted as Government property and equipment.
- h. Weight Handling Equipment (WHE) Accident. A WHE accident occurs when any one or more of the six elements in the operating envelope fails to perform correctly during operation, including operation during

REPAIR AIRFIELD RAMP LIGHTS

maintenance or testing resulting in personnel injury or death; material or equipment damage; dropped load; derailment; two-blocking; overload; and/or collision, including unplanned contact between the load, crane, and/or other objects. A dropped load, derailment, two-blocking, overload and collision are considered accidents even though no material damage or injury occurs. A component failure (e.g., motor burnout, gear tooth failure, bearing failure) is not considered an accident solely due to material or equipment damage unless the component failure results in damage to other components (e.g., dropped boom, dropped load, roll over, etc.).

1.4 CONTRACTOR SAFETY SELF-EVALUATION CHECKLIST

Contracting Officer will provide a "Contractor Safety Self-Evaluation checklist" to the Contractor at the pre-construction conference. The checklist will be completed monthly by the Contractor and submitted with each request for payment voucher. An acceptable score of 90 or greater is required. Failure to submit the completed safety self-evaluation checklist or achieve a score of at least 90, will result in a retention of up to 10 percent of the voucher.

1.5 REGULATORY REQUIREMENTS

In addition to the detailed requirements included in the provisions of this contract, comply with USACE EM 385-1-1, and applicable federal, state, and local laws, ordinances, criteria, rules and regulations. Submit matters of interpretation of standards to the appropriate administrative agency for resolution before starting work. Where the requirements of this specification, applicable laws, criteria, ordinances, regulations, and referenced documents vary, the most stringent requirements govern.

1.6 SITE QUALIFICATIONS, DUTIES AND MEETINGS

1.6.1 Personnel Qualifications

1.6.1.1 Site Safety and Health Officer (SSHO)

Provide a site Safety and Health Officer (SSHO) at the work site at all times to perform safety and occupational health management, surveillance, inspections, and safety enforcement for the Contractor. The Contractor Quality Control (QC) person can be the SSHO on this project. Meet the following requirements within the SSHO:

Level 2:

A minimum of 3 years safety work on similar project.
30-hour OSHA construction safety class or equivalent within last 3 years.
Competent person training as needed.

1.6.1.2 Competent Person for Confined Space Entry

Provide a competent person for confined space meeting the definition and requirements of EM 385-1-1.

1.6.1.3 Crane Operators

Meet the crane operators requirements in USACE EM 385-1-1, Section 16 and Appendix G. In addition, for mobile cranes with Original Equipment Manufacturer (OEM) rated capacities of 50,000 pounds or greater, designate

REPAIR AIRFIELD RAMP LIGHTS

crane operators as qualified by a source that qualifies crane operators (i.e., union, a government agency, or and organization that tests and qualifies crane operators). Provide proof of current qualification.

1.6.2 Personnel Duties

1.6.2.1 Site Safety and Health Officer (SSHO)

- a. Conduct daily safety and health inspections and maintain a written log which includes area/operation inspected, date of inspection, identified hazards, recommended corrective actions, estimated and actual dates of corrections. Attach safety inspection logs to the Contractors' daily quality control report.
- b. Conduct mishap investigations and complete required reports. Maintain the OSHA Form 300 and Daily Production reports for prime and sub-contractors.
- c. Maintain applicable safety reference material on the job site.
- d. Attend the pre-construction conference, pre-work meetings including preparatory inspection meeting, and periodic in-progress meetings.
- e. Implement and enforce accepted APPS and AHAs.
- f. Maintain a safety and health deficiency tracking system that monitors outstanding deficiencies until resolution. Post a list of unresolved safety and health deficiencies on the safety bulletin board.
- g. Ensure sub-contractor compliance with safety and health requirements.

Failure to perform the above duties will result in dismissal of the superintendent and/or SSHO, and a project work stoppage. The project work stoppage will remain in effect pending approval of a suitable replacement.

1.6.3 Meetings

1.6.3.1 Preconstruction Conference

- a. Contractor representatives who have a responsibility or significant role in accident prevention on the project shall attend the preconstruction conference. This includes the project superintendent, site safety and health officer, quality control supervisor, or any other assigned safety and health professionals who participated in the development of the APP (including the Activity Hazard Analyses (AHAs) and special plans, program and procedures associated with it).
- b. Discuss the details of the submitted APP to include incorporated plans, programs, procedures and a listing of anticipated AHAs that will be developed and implemented during the performance of the contract. This list of proposed AHAs will be reviewed at the conference and an agreement will be reached between the Contractor and the Contracting Officer's representative as to which phases will require an analysis. In addition, establish a schedule for the preparation, submittal, review, and acceptance of AHAs to preclude project delays.
- c. Deficiencies in the submitted APP will be brought to the attention of the Contractor at the preconstruction conference, and the Contractor

REPAIR AIRFIELD RAMP LIGHTS

shall revise the plan to correct deficiencies and re-submit it for acceptance. Do not begin work until there is an accepted APP.

d. The functions of a Preconstruction conference may take place at the Post-Award Kickoff meeting for Design Build Contracts.

1.6.3.2 Safety Meetings

Conduct and document meetings as required by EM 385-1-1. Attach minutes showing contract title, signatures of attendees and a list of topics discussed to the Contractors' daily quality control report.

1.7 ACCIDENT PREVENTION PLAN (APP)

Use a qualified person to prepare the written site-specific APP. Prepare the APP in accordance with the format and requirements of USACE EM 385-1-1 and as supplemented herein. Cover all paragraph and subparagraph elements in USACE EM 385-1-1, Appendix A, "Minimum Basic Outline for Accident Prevention Plan" and show compliance with NASA NPG 8715.3. Specific requirements for some of the APP elements are described below. The APP shall be job-specific and address any unusual or unique aspects of the project or activity for which it is written. The APP shall interface with the Contractor's overall safety and health program. Include any portions of the Contractor's overall safety and health program referenced in the APP in the applicable APP element and made site-specific. The Government considers the Prime Contractor to be the "controlling authority" for all work site safety and health of the subcontractors. Contractors are responsible for informing their subcontractors of the safety provisions under the terms of the contract and the penalties for noncompliance, coordinating the work to prevent one craft from interfering with or creating hazardous working conditions for other crafts, and inspecting subcontractor operations to ensure that accident prevention responsibilities are being carried out. The APP shall be signed by the person and firm (senior person) preparing the APP, the Contractor, the on-site superintendent, the designated site safety and health officer and any designated CSP and/or CIH.

Submit the APP to the Contracting Officer 15 calendar days prior to the date of the preconstruction conference for acceptance. Work cannot proceed without an accepted APP.

Once accepted by the Contracting Officer, the APP and attachments will be enforced as part of the contract. Disregarding the provisions of this contract or the accepted APP will be cause for stopping of work, at the discretion of the Contracting Officer, until the matter has been rectified.

Once work begins, changes to the accepted APP shall be made with the knowledge and concurrence of the Contracting Officer, project superintendent, SSSH and quality control manager. Should any hazard become evident, stop work in the area, secure the area, and develop a plan to remove the hazard. Notify the Contracting Officer within 24 hours of discovery. Eliminate/remove the hazard. In the interim, take all necessary action to restore and maintain safe working conditions in order to safeguard onsite personnel, visitors, the public (as defined by ASSE/SAFE A10.34,) and the environment.

Copies of the accepted plan will be maintained at the resident engineer's office and at the job site.

Continuously reviewed and amended the APP, as necessary, throughout the

REPAIR AIRFIELD RAMP LIGHTS

life of the contract. Incorporate unusual or high-hazard activities not identified in the original APP as they are discovered.

1.7.1 EM 385-1-1 Contents

In addition to the requirements outlines in Appendix A of USACE EM 385-1-1, the following is required:

- a. Names and qualifications (resumes including education, training, experience and certifications) of all site safety and health personnel designated to perform work on this project to include the designated site safety and health officer and other competent and qualified personnel to be used such as CSPs, CIHs, STSSs, CHSTs. Specify the duties of each position.
- b. Qualifications of competent and of qualified persons. As a minimum, designate and submit qualifications of competent persons for each of the following major areas: excavation; scaffolding; fall protection; hazardous energy; confined space; health hazard recognition, evaluation and control of chemical, physical and biological agents; personal protective equipment and clothing to include selection, use and maintenance.
- c. Confined Space Entry Plan. Develop a confined space entry plan in accordance with USACE EM 385-1-1, applicable OSHA standards 29 CFR 1910, 29 CFR 1915, and 29 CFR 1926, and any other federal, state and local regulatory requirements identified in this contract. Identify the qualified person's name and qualifications, training, and experience. Delineate the qualified person's authority to direct work stoppage in the event of hazardous conditions. Include procedure for rescue by contractor personnel and the coordination with emergency responders. (If there is no confined space work, include a statement that no confined space work exists and none will be created.)
- d. Crane Critical Lift Plan. Prepare and sign weight handling critical lift plans for lifts over 75 percent of the capacity of the crane or hoist (or lifts over 50 percent of the capacity of a barge mounted mobile crane's hoists) at any radius of lift; lifts involving more than one crane or hoist; lifts of personnel; and lifts involving non-routine rigging or operation, sensitive equipment, or unusual safety risks. Submit 15 calendar days prior to on-site work and include the requirements of USACE EM 385-1-1, paragraph 16.C.18. and the following:
 - (1) For lifts of personnel, demonstrate compliance with the requirements of 29 CFR 1926.550(g).
 - (2) For barge mounted mobile cranes, barge stability calculations identifying barge list and trim based on anticipated loading; and load charts based on calculated list and trim. The amount of list and trim shall be within the crane manufacturer's requirements.
- e. Fall Protection and Prevention (FP&P) Plan. The plan shall be site specific and address all fall hazards in the work place and during different phases of construction. Address how to protect and prevent workers from falling to lower levels when they are exposed to fall hazards above 1.8 m (6 feet). A qualified person for fall protection shall prepare and sign the plan. Include fall protection and

REPAIR AIRFIELD RAMP LIGHTS

prevention systems, equipment and methods employed for every phase of work, responsibilities, assisted rescue, self-rescue and evacuation procedures, training requirements, and monitoring methods. Keep and maintain the accepted Fall Protection and Prevention Plan at the job site for the duration of the project. Include the Fall Protection and Prevention Plan in the Accident Prevention Plan (APP).

1.8 ACTIVITY HAZARD ANALYSIS (AHA)

The Activity Hazard Analysis (AHA) format shall be in accordance with USACE EM 385-1-1. Submit the AHA for review at least 15 calendar days prior to the start of each phase. Format subsequent AHAs as amendments to the APP. The analysis should be used during daily inspections to ensure the implementation and effectiveness of the activity's safety and health controls.

The AHA list will be reviewed periodically (at least monthly) at the Contractor supervisory safety meeting and updated as necessary when procedures, scheduling, or hazards change.

Develop the activity hazard analyses using the project schedule as the basis for the activities performed. Any activities listed on the project schedule will require an AHA. The AHAs will be developed by the contractor, supplier or subcontractor and provided to the prime contractor for submittal to the Contracting Officer.

1.9 DISPLAY OF SAFETY INFORMATION

Within 1 calendar days after commencement of work, erect a safety bulletin board at the job site. Include and maintain information on safety bulletin board as required by EM 385-1-1, section 01.A.06. Additional items required to be posted include:

- a. Confined space entry permit.
- b. Hot work permit.

1.10 SITE SAFETY REFERENCE MATERIALS

Maintain safety-related references applicable to the project, including those listed in the article "References." Maintain applicable equipment manufacturer's manuals.

1.11 EMERGENCY MEDICAL TREATMENT

Contractors will arrange for their own emergency medical treatment. Government has no responsibility to provide emergency medical treatment.

1.12 REPORTS

1.12.1 Accident Reports

- a. Conduct an accident investigation for recordable injuries and illnesses, and property damage accidents resulting in at least \$2,000 in damages, to establish the root cause(s) of the accident, complete the Navy Contractor Significant Incident Report (CSIR) form USACE Accident Report Form 3394 and provide the report to the Contracting Officer within 5 calendar day(s) of the accident. The Contracting Officer will provide copies of any required or special forms.

REPAIR AIRFIELD RAMP LIGHTS

b. Conduct an accident investigation for any weight handling equipment accident (including rigging gear accidents) to establish the root cause(s) of the accident, complete the WHE Accident Report (Crane and Rigging Gear) form and provide the report to the Contracting Officer within 30 calendar days of the accident. Do not proceed with crane operations until cause is determined and corrective actions have been implemented to the satisfaction of the contracting officer. The Contracting Officer will provide a blank copy of the accident report form.

1.12.2 Accident Notification

Notify the Contracting Officer as soon as practical, but not later than four hours, after any accident meeting the definition of Recordable Injuries or Illnesses or High Visibility Accidents, property damage equal to or greater than \$2,000, or any weight handling equipment accident in accordance with NASA NPG 8621.1. Within notification include contractor name; contract title; type of contract; name of activity, installation or location where accident occurred; date and time of accident; names of personnel injured; extent of property damage, if any; extent of injury, if known, and brief description of accident (to include type of construction equipment used, PPE used, etc.). Preserve the conditions and evidence on the accident site until the Government investigation team arrives on-site and Government investigation is conducted.

1.12.3 Monthly Exposure Reports

Monthly exposure reporting to the Contracting Officer is required to be attached to the monthly billing request. This report is a compilation of employee-hours worked each month for all site workers, both prime and subcontractor. The Contracting Officer will provide copies of any special forms.

1.12.4 Crane Reports

Submit crane inspection reports required in accordance with USACE EM 385-1-1, Appendix H and as specified herein with Daily Reports of Inspections.

1.12.5 Certificate of Compliance

Provide a Certificate of Compliance for each crane entering an activity under this contract (see Contracting Officer for a blank certificate). State within the certificate that the crane and rigging gear meet applicable OSHA regulations (with the Contractor citing which OSHA regulations are applicable, e.g., cranes used in construction, demolition, or maintenance comply with 29 CFR 1926 and USACE EM 385-1-1 section 16 and Appendix H. Certify on the Certificate of Compliance that the crane operator(s) is qualified and trained in the operation of the crane to be used. Also certify that all of its crane operators working on the DOD activity have been trained in the proper use of all safety devices (e.g., anti-two block devices). Post certifications on the crane.

1.13 FACILITY OCCUPANCY CLOSURE

Streets, walks, and other facilities occupied and used by the Government shall not be closed or obstructed without written permission from the Contracting Officer.

REPAIR AIRFIELD RAMP LIGHTS

1.14 SEVERE STORM PLAN

In the event of a severe storm warning, the Contractor must:

- a. Secure outside equipment and materials and place materials that could be damaged in protected areas.
- b. Check surrounding area, including roof, for loose material, equipment, debris, and other objects that could be blown away or against existing facilities.
- c. Ensure that temporary erosion controls are adequate.

PART 2 PRODUCTS

Not used.

2.1 FALL PROTECTION ANCHORAGE

Leave in place fall protection anchorage, conforming to ASSE/SAFE Z359.1, installed under the supervision of a qualified person in fall protection, for continued customer use and so identified by signage stating the capacity of the anchorage (strength and number of persons who may be tied-off to it at any one time).

PART 3 EXECUTION

3.1 CONSTRUCTION AND/OR OTHER WORK

Comply with USACE EM 385-1-1, NFPA 241, the APP, the AHA, Federal and/or State OSHA regulations, and other related submittals and activity fire and safety regulations. The most stringent standard prevails.

3.1.1 Hazardous Material Use

Each hazardous material must receive approval prior to being brought onto the job site or prior to any other use in connection with this contract. Allow a minimum of 10 working days for processing of the request for use of a hazardous material.

3.1.2 Hazardous Material Exclusions

Notwithstanding any other hazardous material used in this contract, radioactive materials or instruments capable of producing ionizing/non-ionizing radiation (with the exception of radioactive material and devices used in accordance with USACE EM 385-1-1 such as nuclear density meters for compaction testing and laboratory equipment with radioactive sources) as well as materials which contain asbestos, mercury or polychlorinated biphenyls, di-isocyanates, lead-based paint are prohibited. The Contracting Officer, upon written request by the Contractor, may consider exceptions to the use of any of the above excluded materials.

3.1.3 Unforeseen Hazardous Material

If material, not indicated, that may be hazardous to human health upon disturbance during construction operations is encountered, stop that portion of work and notify the Contracting Officer immediately. Within 14 calendar days the Government will determine if the material is hazardous.

REPAIR AIRFIELD RAMP LIGHTS

If material is not hazardous or poses no danger, the Government will direct the Contractor to proceed without change. If material is hazardous and handling of the material is necessary to accomplish the work, the Government will issue a modification pursuant to "FAR 52.243-4, Changes" and "FAR 52.236-2, Differing Site Conditions."

3.2 PRE-OUTAGE COORDINATION MEETING

Contractors are required to apply for utility outages at least 15 days in advance. As a minimum, the request should include the location of the outage, utilities being affected, duration of outage and any necessary sketches. Special requirements for electrical outage requests are contained elsewhere in this specification section. Once approved, and prior to beginning work on the utility system requiring shut down, attend a pre-outage coordination meeting with the Contracting Officer to review the scope of work and the lock-out/tag-out procedures for worker protection. No work will be performed on energized electrical circuits unless proof is provided that no other means exist.

3.3 SAFETY LOCKOUT/TAGOUT PROCEDURES

Contractor shall ensure that each employee is familiar with and complies with these procedures and 29 CFR 1910.147.

Contracting Officer will, at the Contractor's request, apply lockout/tagout tags and take other actions that, because of experience and knowledge, are known to be necessary to make the particular equipment safe to work on.

No person, regardless of position or authority, shall operate any switch, valve, or equipment that has an official lockout/tagout tag attached to it, nor shall such tag be removed except as provided in this section.

No person shall work on any equipment that requires a lockout/tagout tag unless he, his immediate supervisor, project leader, or a subordinate has in his possession the stubs of the required lockout/tagout tags.

When work is to be performed on electrical circuits, only qualified personnel shall perform work on electrical circuits.

A supervisor who is required to enter an area protected by a lockout/tagout tag will be considered a member of the protected group provided he notifies the holder of the tag stub each time he enters and departs from the protected area.

Identification markings on building light and power distribution circuits shall not be relied on for established safe work conditions.

Before clearance will be given on any equipment other than electrical (generally referred to as mechanical apparatus), the apparatus, valves, or systems shall be secured in a passive condition with the appropriate vents, pins, and locks.

Pressurized or vacuum systems shall be vented to relieve differential pressure completely.

Vent valves shall be tagged open during the course of the work.

Where dangerous gas or fluid systems are involved, or in areas where the

REPAIR AIRFIELD RAMP LIGHTS

environment may be oxygen deficient, system or areas shall be purged, ventilated, or otherwise made safe prior to entry.

3.3.1 Tag Placement

Lockout/tagout tags shall be completed in accordance with the regulations printed on the back thereof and attached to any device which, if operated, could cause an unsafe condition to exist.

If more than one group is to work on any circuit or equipment, the employee in charge of each group shall have a separate set of lockout/tagout tags completed and properly attached.

When it is required that certain equipment be tagged, the Government will review the characteristics of the various systems involved that affect the safety of the operations and the work to be done; take the necessary actions, including voltage and pressure checks, grounding, and venting, to make the system and equipment safe to work on; and apply such lockout/tagout tags to those switches, valves, vents, or other mechanical devices needed to preserve the safety provided. This operation is referred to as "Providing Safety Clearance."

3.3.2 Tag Removal

When any individual or group has completed its part of the work and is clear of the circuits or equipment, the supervisor, project leader, or individual for whom the equipment was tagged shall turn in his signed lockout/tagout tag stub to the Contracting Officer. That group's or individual's lockout/tagout tags on equipment may then be removed on authorization by the Contracting Officer.

3.4 FALL HAZARD PROTECTION AND PREVENTION PROGRAM

Establish a fall protection and prevention program, for the protection of all employees exposed to fall hazards. Within the program include company policy, identify responsibilities, education and training requirements, fall hazard identification, prevention and control measures, inspection, storage, care and maintenance of fall protection equipment and rescue and evacuation procedures.

3.4.1 Training

Institute a fall protection training program. As part of the Fall Hazard Protection and Prevention Program, provide training for each employee who might be exposed to fall hazards. Provide training by a competent person for fall protection in accordance with USACE EM 385-1-1, section 21.A.16.

3.4.2 Fall Protection Equipment and Systems

Enforce use of the fall protection equipment and systems designated for each specific work activity in the Fall Protection and Prevention Plan and/or AHA at all times when an employee is exposed to a fall hazard. Protect employees from fall hazards as specified in EM 385-1-1, section 21. In addition to the required fall protection systems, safety skiff, personal floatation devices, life rings etc., are required when working above or next to water in accordance with USACE EM 385-1-1, paragraphs 05.H. and 05.I. Personal fall arrest systems are required when working from an articulating or extendible boom, swing stages, or suspended platform. In addition, personal fall arrest systems are required when

REPAIR AIRFIELD RAMP LIGHTS

operating other equipment such as scissor lifts if the work platform is capable of being positioned outside the wheelbase. The need for tying-off in such equipment is to prevent ejection of the employee from the equipment during raising, lowering, or travel. Fall protection must comply with 29 CFR 1926.500, Subpart M, USACE EM 385-1-1 and ASSE/SAFE A10.32.

3.4.2.1 Personal Fall Arrest Equipment

Personal fall arrest equipment, systems, subsystems, and components shall meet ASSE/SAFE Z359.1. Only a full-body harness with a shock-absorbing lanyard or self-retracting lanyard is an acceptable personal fall arrest body support device. Body belts may only be used as a positioning device system (for uses such as steel reinforcing assembly and in addition to an approved fall arrest system). Harnesses shall have a fall arrest attachment affixed to the body support (usually a Dorsal D-ring) and specifically designated for attachment to the rest of the system. Only locking snap hooks and carabiners shall be used. Webbing, straps, and ropes shall be made of synthetic fiber. The maximum free fall distance when using fall arrest equipment shall not exceed 6 feet. The total fall distance and any swinging of the worker (pendulum-like motion) that can occur during a fall shall always be taken into consideration when attaching a person to a fall arrest system.

3.4.3 Fall Protection for Roofing Work

Implement fall protection controls based on the type of roof being constructed and work being performed. Evaluate the roof area to be accessed for its structural integrity including weight-bearing capabilities for the projected loading.

a. Low Sloped Roofs:

(1) For work within 1.8 m (6 feet) of an edge, on low-slope roofs, Protect personnel from falling by use of personal fall arrest systems, guardrails, or safety nets. A safety monitoring system is not adequate fall protection and is not authorized.

(2) For work greater than 1.8 m (6 feet) from an edge, erect and install warning lines in accordance with 29 CFR 1926.500 and USACE EM 385-1-1.

b. Steep-Sloped Roofs: Work on steep-sloped roofs requires a personal fall arrest system, guardrails with toe-boards, or safety nets. This requirement also includes residential or housing type construction.

3.4.4 Existing Anchorage

Certified (or re-certified) by a qualified person for fall protection eexisting anchorages, to be used for attachment of personal fall arrest equipmentin accordance with ASSE/SAFE Z359.1. Exiting horizontal lifeline anchorages must be certified (or re-certified) by a registered professional engineer with experience in designing horizontal lifeline systems.

3.4.5 Horizontal Lifelines

Design, install, certify and use under the supervision of a qualified person horizontal lifelines for fall protection as part of a complete fall arrest system which maintains a safety factor of 2 (29 CFR 1926.500).

REPAIR AIRFIELD RAMP LIGHTS

3.4.6 Guardrails and Safety Nets

Design, install and use guardrails and safety nets in accordance with EM 385-1-1 and 29 CFR 1926 Subpart M.

3.4.7 Rescue and Evacuation Procedures

When personal fall arrest systems are used, the contractor must ensure that the mishap victim can self-rescue or can be rescued promptly should a fall occur. Prepare a Rescue and Evacuation Plan and include a detailed discussion of the following: methods of rescue; methods of self-rescue; equipment used; training requirement; specialized training for the rescuers; procedures for requesting rescue and medical assistance; and transportation routes to a medical facility. Include the Rescue and Evacuation Plan within the Activity Hazard Analysis (AHA) for the phase of work, in the Fall Protection and Prevention (FP&P) Plan, and the Accident Prevention Plan (APP).

3.5 SCAFFOLDING

3.5.1 Stilts

The use of stilts for gaining additional height in construction, renovation, repair or maintenance work is prohibited.

3.6 EQUIPMENT

3.6.1 Material Handling Equipment

a. Material handling equipment such as forklifts shall not be modified with work platform attachments for supporting employees unless specifically delineated in the manufacturer's printed operating instructions.

b. The use of hooks on equipment for lifting of material must be in accordance with manufacturer's printed instructions.

c. Operators of forklifts or power industrial trucks shall be licensed in accordance with OSHA.

3.6.2 Weight Handling Equipment

a. Equip cranes and derricks as specified in EM 385-1-1, section 16.

b. Notify the Contracting Officer 15 days in advance of any cranes entering the activity so that necessary quality assurance spot checks can be coordinated. Prior to cranes entering federal activities, a Crane Access Permit must be obtained from the Contracting Officer. A copy of the permitting process will be provided at the Preconstruction Conference. Contractor's operator shall remain with the crane during the spot check.

c. Comply with the crane manufacturer's specifications and limitations for erection and operation of cranes and hoists used in support of the work. Perform erection under the supervision of a designated person (as defined in ASME B30.5). Perform all testing in accordance with the manufacturer's recommended procedures.

d. Comply with ASME B30.5 for mobile and locomotive cranes, ASME B30.22

REPAIR AIRFIELD RAMP LIGHTS

for articulating boom cranes, ASME B30.3 for construction tower cranes, and ASME B30.8 for floating cranes and floating derricks.

e. Under no circumstance shall a Contractor make a lift at or above 90% of the cranes rated capacity in any configuration.

f. When operating in the vicinity of overhead transmission lines, operators and riggers shall be alert to this special hazard and follow the requirements of USACE EM 385-1-1 section 11 and ASME B30.5 or ASME B30.22 as applicable.

g. Do not crane suspended personnel work platforms (baskets) unless the Contractor proves that using any other access to the work location would provide a greater hazard to the workers or is impossible. Do not lift personnel with a line hoist or friction crane.

h. Inspect, maintain, and recharge portable fire extinguishers as specified in NFPA 10, Standard for Portable Fire Extinguishers.

i. All employees must keep clear of loads about to be lifted and of suspended loads.

j. Use cribbing when performing lifts on outriggers.

k. The crane hook/block must be positioned directly over the load. Side loading of the crane is prohibited.

l. A physical barricade must be positioned to prevent personnel from entering the counterweight swing (tail swing) area of the crane.

m. Certification records which include the date of inspection, signature of the person performing the inspection, and the serial number or other identifier of the crane that was inspected shall always be available for review by Contracting Officer personnel.

n. Written reports listing the load test procedures used along with any repairs or alterations performed on the crane shall be available for review by Contracting Officer personnel.

o. Certify that all crane operators have been trained in proper use of all safety devices (e.g. anti-two block devices).

p. Take steps to ensure that wind speed does not contribute to loss of control of the load during lifting operations. Prior to conducting lifting operations set a maximum wind speed at which a crane can be safely operated based on the equipment being used, the load being lifted, experience of operators and riggers, and hazards on the work site. This maximum wind speed determination shall be included as part of the activity hazard analysis plan for that operation.

3.6.3 Equipment and Mechanized Equipment

a. Proof of qualifications for operator shall be kept on the project site for review.

b. Manufacture specifications or owner's manual for the equipment shall be on-site and reviewed for additional safety precautions or requirements that are sometimes not identified by OSHA or USACE EM 385-1-1. Incorporate such additional safety precautions or

REPAIR AIRFIELD RAMP LIGHTS

requirements into the AHAs.

3.6.4 USE OF EXPLOSIVES

Explosives shall not be used or brought to the project site without prior written approval from the Contracting Officer. Such approval shall not relieve the Contractor of responsibility for injury to persons or for damage to property due to blasting operations.

Storage of explosives, when permitted on Government property, shall be only where directed and in approved storage facilities. These facilities shall be kept locked at all times except for inspection, delivery, and withdrawal of explosives.

Explosive work shall be performed in accordance with NASA NSS 1740.12. This document is available at:

<http://www.hq.nasa.gov/office/codeq/doctree/871912.htm>

3.7 EXCAVATIONS

Perform soil classification by a competent person in accordance with 29 CFR 1926.

3.7.1 Utility Locations

Prior to digging, the appropriate digging permit must be obtained. All underground utilities in the work area must be positively identified by a private utility locating service in addition to any station locating service and coordinated with the station utility department. Any markings made during the utility investigation must be maintained throughout the contract.

3.7.2 Utility Location Verification

The Contractor must physically verify underground utility locations by hand digging using wood or fiberglass handled tools when any adjacent construction work is expected to come within three feet of the underground system. Digging within 2 feet of a known utility must not be performed by means of mechanical equipment; hand digging shall be used. If construction is parallel to an existing utility expose the utility by hand digging every 30.5 m (100 feet) if parallel within 1.5 m (5 feet) of the excavation.

3.7.3 Shoring Systems

Trench and shoring systems must be identified in the accepted safety plan and AHA. Manufacture tabulated data and specifications or registered engineer tabulated data for shoring or benching systems shall be readily available on-site for review. Job-made shoring or shielding must have the registered professional engineer stamp, specifications, and tabulated data. Extreme care must be used when excavating near direct burial electric underground cables.

3.7.4 Trenching Machinery

Operate trenching machines with digging chain drives only when the spotters/laborers are in plain view of the operator. Provide operator and spotters/laborers training on the hazards of the digging chain drives with emphasis on the distance that needs to be maintained when the digging chain

REPAIR AIRFIELD RAMP LIGHTS

is operating. Keep documentation of the training on file at the project site.

3.8 UTILITIES WITHIN CONCRETE SLABS

Utilities located within concrete slabs or pier structures, bridges, and the like, are extremely difficult to identify due to the reinforcing steel used in the construction of these structures. Whenever contract work involves concrete chipping, saw cutting, or core drilling, the existing utility location must be coordinated with station utility departments in addition to a private locating service. Outages to isolate utility systems must be used in circumstances where utilities are unable to be positively identified. The use of historical drawings does not alleviate the contractor from meeting this requirement.

3.9 ELECTRICAL

3.9.1 Conduct of Electrical Work

Underground electrical spaces must be certified safe for entry before entering to conduct work. Cables that will be cut must be positively identified and de-energized prior to performing each cut. Positive cable identification must be made prior to submitting any outage request for electrical systems. Arrangements are to be coordinated with the Contracting Officer and Station Utilities for identification. The Contracting Officer will not accept an outage request until the Contractor satisfactorily documents that the circuits have been clearly identified. Perform all high voltage cable cutting remotely using hydraulic cutting tool. When racking in or live switching of circuit breakers, no additional person other than the switch operator will be allowed in the space during the actual operation. Plan so that work near energized parts is minimized to the fullest extent possible. Use of electrical outages clear of any energized electrical sources is the preferred method. When working in energized substations, only qualified electrical workers will be permitted to enter. When work requires Contractor to work near energized circuits as defined by the NFPA 70, high voltage personnel must use personal protective equipment that includes, as a minimum, electrical hard hat, safety shoes, insulating gloves with leather protective sleeves, fire retarding shirts, coveralls, face shields, and safety glasses. In addition, provide electrical arc flash protection for personnel as required by NFPA 70E. Insulating blankets, hearing protection, and switching suits may also be required, depending on the specific job and as delineated in the Contractor's AHA.

3.9.2 Portable Extension Cords

Size portable extension cords in accordance with manufacturer ratings for the tool to be powered and protected from damage. Immediately removed from service all damaged extension cords. Portable extension cords shall meet the requirements of NFPA 70.

3.10 WORK IN CONFINED SPACES

Comply with the requirements in Section 06.I of USACE EM 385-1-1, OSHA 29 CFR 1910.146 and OSHA 29 CFR 1926.21(b)(6). Any potential for a hazard in the confined space requires a permit system to be used.

- a. Entry Procedures. Prohibit entry into a confined space by personnel for any purpose, including hot work, until the qualified

REPAIR AIRFIELD RAMP LIGHTS

person has conducted appropriate tests to ensure the confined or enclosed space is safe for the work intended and that all potential hazards are controlled or eliminated and documented. (See Section 06.I.06 of USACE EM 385-1-1 for entry procedures.) All hazards pertaining to the space shall be reviewed with each employee during review of the AHA.

b. Forced air ventilation is required for all confined space entry operations and the minimum air exchange requirements must be maintained to ensure exposure to any hazardous atmosphere is kept below its' action level.

c. Sewer wet wells require continuous atmosphere monitoring with audible alarm for toxic gas detection.

-- End of Section --

SECTION 03 30 53

MISCELLANEOUS CAST-IN-PLACE CONCRETE
04/08

PART 1 GENERAL

1.1 SUMMARY

Perform all work in accordance with ACI MCP SET Parts 2 and 3.

1.2 REFERENCES

The publications listed below form a part of this specification to the extent referenced. The publications are referred to within the text by the basic designation only.

ACI INTERNATIONAL (ACI)

ACI MCP SET (2008) Manual of Concrete Practice

ASTM INTERNATIONAL (ASTM)

ASTM A 185/A 185M (2007) Standard Specification for Steel Welded Wire Reinforcement, Plain, for Concrete

ASTM A 615/A 615M (2008b) Standard Specification for Deformed and Plain Carbon-Steel Bars for Concrete Reinforcement

ASTM C 1064/C 1064M (2008) Standard Test Method for Temperature of Freshly Mixed Hydraulic-Cement Concrete

ASTM C 143/C 143M (2008) Standard Test Method for Slump of Hydraulic-Cement Concrete

ASTM C 150 (2007) Standard Specification for Portland Cement

ASTM C 172 (2008) Standard Practice for Sampling Freshly Mixed Concrete

ASTM C 173/C 173M (2008) Standard Test Method for Air Content of Freshly Mixed Concrete by the Volumetric Method

ASTM C 231 (2008c) Standard Test Method for Air Content of Freshly Mixed Concrete by the Pressure Method

ASTM C 260 (2006) Standard Specification for Air-Entraining Admixtures for Concrete

ASTM C 309 (2007) Standard Specification for Liquid Membrane-Forming Compounds for Curing

REPAIR AIRFIELD RAMP LIGHTS

	Concrete
ASTM C 31/C 31M	(2008a) Standard Practice for Making and Curing Concrete Test Specimens in the Field
ASTM C 33	(2007) Standard Specification for Concrete Aggregates
ASTM C 39/C 39M	(2005e1e2) Standard Test Method for Compressive Strength of Cylindrical Concrete Specimens
ASTM C 494/C 494M	(2008a) Standard Specification for Chemical Admixtures for Concrete
ASTM C 618	(2008a) Standard Specification for Coal Fly Ash and Raw or Calcined Natural Pozzolan for Use in Concrete
ASTM C 685/C 685M	(2007) Concrete Made by Volumetric Batching and Continuous Mixing
ASTM C 94/C 94M	(2007) Standard Specification for Ready-Mixed Concrete
ASTM D 75	(2003) Standard Practice for Sampling Aggregates

U.S. ARMY CORPS OF ENGINEERS (USACE)

COE CRD-C 400	(1963) Requirements for Water for Use in Mixing or Curing Concrete
---------------	--

1.3 SYSTEM DESCRIPTION

The Government retains the option to sample and test aggregates and concrete to determine compliance with the specifications. Provide facilities and labor as may be necessary to assist the Government in procurement of representative test samples. Obtain samples of aggregates at the point of batching in accordance with ASTM D 75. Sample concrete in accordance with ASTM C 172. Determine slump and air content in accordance with ASTM C 143/C 143M and ASTM C 231, respectively, when cylinders are molded. Prepare, cure, and transport compression test specimens in accordance with ASTM C 31/C 31M. Test compression test specimens in accordance with ASTM C 39/C 39M. Take samples for strength tests not less than once each shift in which concrete is produced. Provide a minimum of five specimens from each sample; two to be tested at 28 days, two will be tested at 7 days and one hold sample.

1.3.1 Strength

Acceptance test results are the average strengths of two specimens tested at 28 days. The strength of the concrete is considered satisfactory so long as the average of three consecutive acceptance test results equal or exceed the specified compressive strength, f'c, and no individual acceptance test result falls below f'c by more than 500 psi.

REPAIR AIRFIELD RAMP LIGHTS

1.3.2 Construction Tolerances

Apply a Class "C" finish to all surfaces except those specified to receive a Class "D" finish. Apply a Class "D" finish to all post-construction surfaces which will be permanently concealed. Surface requirements for the classes of finish required are as specified in Part 4 of ACI MCP SET.

1.3.3 Concrete Mixture Proportions

Concrete mixture proportions are the responsibility of the Contractor. Mixture proportions shall include the dry weights of cementitious material(s); the nominal maximum size of the coarse aggregate; the specific gravities, absorptions, and saturated surface-dry weights of fine and coarse aggregates; the quantities, types, and names of admixtures; and quantity of water per cubic yard of concrete. Provide materials included in the mixture proportions of the same type and from the same source as will be used on the project. Specified compressive strength f'c shall be 3,500 psi at 28 days. The maximum nominal size coarse aggregate is 1 inch, in accordance with ACI MCP SET Part 3. The maximum water cement ratio is 0.45. Slump shall be between 2 and 5 inches. Provide air content between 4.5 and 7.5 percent for portion of concrete exposed to weather.

1.4 SUBMITTALS

Submit the following in accordance with Section 01 11 00 SPECIAL CONDITIONS, Paragraph 1.2:

SD-03 Product Data

Retarding Admixture

Conveying and Placing Concrete

Methods and equipment for transporting, handling, depositing, and consolidating the concrete prior to the first concrete placement.

Formwork

Formwork design prior to the first concrete placement.

Mix Design Data

Steel Reinforcement

Accessories

Curing Compound

Concrete

SD-06 Test Reports

Concrete Mixture Proportions; G

The mixture proportions that will produce concrete of the quality required, ten days prior to placement of concrete. Applicable test reports to verify that the concrete mixture proportions selected will produce concrete of the quality specified.

Compressive Strength Testing

Slump

REPAIR AIRFIELD RAMP LIGHTS

SD-07 Certificates

Cementitious Materials

Aggregates

Certificates of compliance stating that the material(s) meet the quality and grading requirements of the specifications under which it is furnished.

1.5 QUALITY ASSURANCE

Indicate specific locations of Concrete Placement, Forms, Steel Reinforcement, Accessories on installation drawings. and include, but not be limited to, square feet of concrete placements, thicknesses and widths, plan dimensions, and arrangement of cast-in-place concrete section.

PART 2 PRODUCTS

2.1 MATERIALS

2.1.1 Cementitious Materials

Provide cementitious materials that conform to the appropriate specifications listed:

2.1.1.1 Portland Cement

ASTM C 150, Type I.

2.1.1.2 Pozzolan

Provide pozzolan that conforms to ASTM C 618, Class C or F, including requirements of Tables 1A and 2A. Limit fly ash between 15 to 35 percent maximum cement replacement by weight.

2.1.2 Aggregates

Fine and coarse aggregates shall meet the quality and grading requirements of ASTM C 33 Class Designations 4M or better.

2.1.3 Admixtures

Admixtures to be used, when required or approved, shall comply with the appropriate specification listed. Retest chemical admixtures that have been in storage at the project site, for longer than 6 months or that have been subjected to freezing, at the expense of the Contractor at the request of the Contracting Officer and will be rejected if test results are not satisfactory.

2.1.3.1 Air-Entraining Admixture

Provide air-entraining admixture that meets the requirements of ASTM C 260, for concrete exposed to the weather.

2.1.3.2 Water-Reducing or Retarding Admixture

Provide water-reducing or retarding admixture meeting the requirements of

REPAIR AIRFIELD RAMP LIGHTS

ASTM C 494/C 494M, Type A, B, or D. High-range water reducing admixture Type F may be used only when approved, approval being contingent upon particular placement requirements as described in the Contractor's Quality Control Plan.

2.1.4 Water

Use fresh, clean, potable water for mixing and curing, free from injurious amounts of oil, acid, salt, or alkali, except that unpotable water may be used if it meets the requirements of COE CRD-C 400.

2.1.5 Reinforcing Steel

Provide reinforcing bars conforming to the requirements of ASTM A 615/A 615M, Grade 60. Welded steel wire fabric shall conform to the requirements of ASTM A 185/A 185M. Details of reinforcement not shown shall be in accordance with ACI MCP SET Part 3, Chapters 7 and 12.

2.1.6 Formwork

The design and engineering of the formwork as well as its construction, will be the responsibility of the Contractor.

2.1.7 Curing Materials

Provide curing materials conforming to the following requirements.

2.1.7.1 Membrane-Forming Curing Compound

ASTM C 309, Type 1-D or 2, Class A.

2.2 STEEL REINFORCEMENT

2.2.1 Deformed Steel Bars

Provide steel bars conforming to ASTM A 615/A 615M, Grade 60 ksi ACI MCP SET Parts 2 and 3.

2.2.2 Welded Wire Fabric

Provide welded wire fabric conforming to ASTM A 185/A 185M.

2.3 FORMS

Forms shall be of wood, steel, or other approved material and conform to ACI MCP SET, Parts 2 and 3.

2.4 ACCESSORIES

2.4.1 Curing Compound

Provide curing compound conforming to ASTM C 309.

REPAIR AIRFIELD RAMP LIGHTS

PART 3 EXECUTION

3.1 PREPARATION

3.1.1 General

Construct ramps and walkways, as necessary, to allow safe and expeditious access for concrete and workmen. Remove snow, ice, standing or flowing water, loose particles, debris, and foreign matter. Earth foundations shall be satisfactorily compacted. Ensure spare vibrators are available. The entire preparation shall be accepted by the Government prior to placing.

3.1.2 Embedded Items

Secure reinforcement in place after joints, anchors, and other embedded items have been positioned. Arrange internal ties so that when the forms are removed the metal part of the tie is not less than 2 inches from concrete surfaces permanently exposed to view or exposed to water on the finished structures. Embedded items shall be free of oil and other foreign matters such as loose coatings or rust, paint, and scale. The embedding of wood in concrete is permitted only when specifically authorized or directed. All equipment needed to place, consolidate, protect, and cure the concrete shall be at the placement site and in good operating condition.

3.1.3 Formwork Installation

Forms shall be properly aligned, adequately supported, and mortar-tight. Provide smooth form surfaces, free from irregularities, dents, sags, or holes when used for permanently exposed faces. Chamfer all exposed joints and edges, unless otherwise indicated.

3.1.4 Production of Concrete

3.1.4.1 Ready-Mixed Concrete

Provide ready-mixed concrete conforming to ASTM C 94/C 94M except as otherwise specified.

3.1.4.2 Concrete Made by Volumetric Batching and Continuous Mixing

Concrete made by volumetric batching and continuous mixing shall conform to ASTM C 685/C 685M.

3.2 CONVEYING AND PLACING CONCRETE

Perform conveying and placing concrete in conformance with the following requirements.

3.2.1 General

Concrete placement is not permitted when weather conditions prevent proper placement and consolidation without approval. When concrete is mixed and/or transported by a truck mixer, deliver the concrete to the site of the work completing the discharge within 1-1/2 hours. Convey concrete from the mixer to the forms as rapidly as practicable by methods which prevent segregation or loss of ingredients. Concrete shall be in place and consolidated within 15 minutes after discharge from the mixer. Deposit concrete as close as possible to its final position in the forms and regulate it so that it may be effectively consolidated in horizontal layers

REPAIR AIRFIELD RAMP LIGHTS

18 inches or less in thickness with a minimum of lateral movement. Carry on the placement at such a rate that the formation of cold joints will be prevented.

3.2.2 Consolidation

Consolidate each layer of concrete by internal vibrating equipment. External vibrating equipment may be used when authorized. Systematically accomplish internal vibration by inserting the vibrator through the fresh concrete in the layer below at a uniform spacing over the entire area of placement. The distance between insertions shall be approximately 1.5 times the radius of action of the vibrator and overlay the adjacent, just-vibrated area by approximately 4 inches. Ensure that the vibrator penetrates rapidly to the bottom of the layer and at least 6 inches into the layer below, if such a layer exists. Hold vibrator stationary until the concrete is consolidated and then withdraw it slowly at the rate of about 3 inches per second.

3.2.3 Cold-Weather Requirements

No concrete is to be mixed or placed when the ambient temperature is below 36 degrees F or if the ambient temperature is below 41 degrees F and falling. Provide suitable covering and other means as approved for maintaining the concrete at a temperature of at least 50 degrees F for not less than 72 hours after placing and at a temperature above freezing for the remainder of the curing period. Do not mix salt, chemicals, or other foreign materials with the concrete to prevent freezing. Remove and replace concrete damaged by freezing at the expense of the Contractor.

3.2.4 Hot-Weather Requirements

When the rate of evaporation of surface moisture, as determined by use of Figure 1 of ACI MCP SET Part 2, is expected to exceed 0.2 psf per hour, provisions for windbreaks, shading, fog spraying, or covering with a light-colored material shall be made in advance of placement, and such protective measures taken as quickly as finishing operations will allow.

3.2.5 Lifts in Concrete

Deposit concrete in horizontal layers not to exceed 24 inches in thickness. Carry on placement at a rate that prevents the formation of cold joints. Place slabs in one lift.

3.3 FORM REMOVAL

Do not remove forms before 24 hours after concrete placement, except as otherwise specifically authorized. Do not remove supporting forms and shoring until the concrete has cured for at least 5 days. When conditions require longer curing periods, forms shall remain in place.

3.4 FINISHING

3.4.1 General

Do not finish or repair concrete when either the concrete or the ambient temperature is below 50 degrees F.

REPAIR AIRFIELD RAMP LIGHTS

3.4.2 Finishing Formed Surfaces

Remove all fins and loose materials , and surface defects including filling of tie holes. Repair all honeycomb areas and other defects. Remove all unsound concrete from areas to be repaired. Surface defects greater than 1/2 inch in diameter and holes left by removal of tie rods in all surfaces not to receive additional concrete shall be reamed or chipped and filled with dry-pack mortar. Brush-coat the prepared area with an approved epoxy resin or latex bonding compound or with a neat cement grout after dampening and filling with mortar or concrete. The cement used in mortar or concrete for repairs to all surfaces permanently exposed to view shall be a blend of portland cement and white cement so that the final color when cured is the same as adjacent concrete.

3.5 CURING AND PROTECTION

Beginning immediately after placement, and continuing for at least 7 days, cure and protect all concrete from premature drying, extremes in temperature, rapid temperature change, freezing, mechanical damage, and exposure to rain or flowing water. Provide all materials and equipment needed for adequate curing and protection at the site of the placement prior to the start of concrete placement.

3.6 TESTS AND INSPECTIONS

3.6.1 General

The individuals who sample and test concrete, as required in this specification, must have demonstrated a knowledge and ability to perform the necessary test procedures equivalent to the ACI minimum guidelines for certification of Concrete Field Testing Technicians, Grade I.

3.6.2 Inspection Details and Frequency of Testing

3.6.2.1 Preparations for Placing

Inspect foundation, forms, and embedded items in sufficient time prior to each concrete placement by the Contractor to certify that it is ready to receive concrete.

3.6.2.2 Air Content

Check air content at least once during each shift that concrete is placed. Obtain samples in accordance with ASTM C 172 and tested in accordance with ASTM C 231.

3.6.2.3 Slump

Check slump once during each shift that concrete is produced. Obtain samples in accordance with ASTM C 172 and tested in accordance with ASTM C 143/C 143M.

3.6.2.4 Consolidation and Protection

Ensure that the concrete is properly consolidated, finished, protected, and cured.

REPAIR AIRFIELD RAMP LIGHTS

3.6.3 Action Required

3.6.3.1 Placing

Do not permit placing to begin until the availability of an adequate number of acceptable vibrators, which are in working order and have competent operators, has been verified. Do not continue placing if any pile is inadequately consolidated.

3.6.3.2 Air Content

Whenever an air content test result is outside the specification limits, adjust the dosage of the air-entrainment admixture prior to delivery of concrete to forms.

3.6.3.3 Slump

Whenever a slump test result is outside the specification limits, adjust the batch weights of water and fine aggregate prior to delivery of concrete to the forms. The adjustments are to be made so that the water-cement ratio does not exceed that specified in the submitted concrete mixture proportion.

3.6.4 Reports

Report the results of all tests and inspections conducted at the project site informally at the end of each shift. Submit written reports weekly. Deliver within 3 days after the end of each weekly reporting period. See Section 01 45 01 USACE QUALITY CONTROL.

3.7 FORM WORK

Form work shall conform to ACI MCP SET Parts 2 through 5.

3.7.1 Preparation of Form Surfaces

Forms shall be true to line and grade, mortar-tight, and sufficiently rigid to prevent objectionable deformation under load. Form surfaces for permanently exposed faces shall be smooth, free from irregularities, dents, sags, or holes. Chamfer exposed joints and exposed edges. Arrange internal ties so that when the forms are removed, the form ties are not less than 2 inches from concrete surfaces permanently exposed to view or exposed to water on the finished structure.

3.7.2 Form Coating

Coat forms, for exposed surfaces, with a nonstaining form release coating applied. Forms for unexposed surfaces may be wetted in lieu of coating immediately before the placing of concrete, except that in freezing weather form release coating shall be used.

3.7.3 Removal of Forms

Remove forms carefully to prevent damage to the concrete.

REPAIR AIRFIELD RAMP LIGHTS

3.8 STEEL REINFORCING

3.8.1 General

Reinforcement shall be free from loose, flaky rust and scale, and free from oil, grease, or other coating which might destroy or reduce the reinforcement's bond with the concrete.

3.8.2 Fabrication

Shop fabricate steel reinforcement in accordance with ACI MCP SET Parts 2 and 3. Shop details and bending shall be in accordance with ACI MCP SET Parts 2 and 3.

3.8.3 Splicing

Perform splices in accordance with ACI MCP SET Parts 2 and 3.

3.8.4 Supports

Secure reinforcement in place by the use of metal or concrete supports, spacers, or ties.

3.9 EMBEDDED ITEMS

Before placing concrete, take care to determine that all embedded items are firmly and securely fastened in place. Provide embedded items free of oil and other foreign matter, such as loose coatings of rust, paint and scale.

3.10 BILL OF LADING

Bill of Lading for each ready-mix concrete delivery shall be in accordance with ASTM C 94/C 94M.

3.11 FIELD TESTING

- a. Provide samples and test concrete for quality control during placement. Sampling of fresh concrete for testing shall be in accordance with ASTM C 172.
- b. Test concrete for compressive strength at 7 and 28 days for each design mix. Concrete test specimens shall conform to ASTM C 31/C 31M. Perform Compressive strength testing conforming to ASTM C 39/C 39M.
- c. Test Slump at the site of discharge for each design mix in accordance with ASTM C 143/C 143M.
- d. Test air content for air-entrained concrete in accordance with ASTM C 231. Test concrete using lightweight or test extremely porous aggregates in accordance with ASTM C 173/C 173M.
- e. Determine temperature of concrete at time of placement in accordance with ASTM C 1064/C 1064M.

-- End of Section --

REPAIR AIRFIELD RAMP LIGHTS

SECTION 26 05 00.00 40

COMMON WORK RESULTS FOR ELECTRICAL

11/08

PART 1 GENERAL

1.1 REFERENCES

The publications listed below form a part of this specification to the extent referenced. The publications are referred to within the text by the basic designation only.

ASTM INTERNATIONAL (ASTM)

ASTM D 709 (2001; R 2007) Laminated Thermosetting Materials

ELECTRONIC INDUSTRIES ALLIANCE (EIA)

EIA 480 (1981) Toggle Switches

INSTITUTE OF ELECTRICAL AND ELECTRONICS ENGINEERS (IEEE)

IEEE C57.12.28 (2005) Standard for Pad-Mounted Equipment - Enclosure Integrity

IEEE C57.12.29 (2005) Pad-Mounted Equipment - Enclosure Integrity for Coastal Environments

IEEE Std 100 (2000) The Authoritative Dictionary of IEEE Standards Terms

NATIONAL ELECTRICAL MANUFACTURERS ASSOCIATION (NEMA)

NEMA 250 (2003) Enclosures for Electrical Equipment (1000 Volts Maximum)

NEMA FB 1 (2007) Standard for Fittings, Cast Metal Boxes, and Conduit Bodies for Conduit, Electrical Metallic Tubing, and Cable

NEMA KS 1 (2001; R 2006) Enclosed and Miscellaneous Distribution Equipment Switches (600 Volts Maximum)

NEMA OS 1 (2003) Standard for Sheet-Steel Outlet Boxes, Device Boxes, Covers, and Box Supports

NEMA PB 1 (2006; Errata 2008) Standard for Panelboards

NEMA RN 1 (2005) Standard for Polyvinyl Chloride (PVC) Externally Coated Galvanized Rigid Steel Conduit and Intermediate Metal Conduit

REPAIR AIRFIELD RAMP LIGHTS

NEMA TC 2	(2003) Standard for Electrical Polyvinyl Chloride (PVC) Tubing and Conduit
NEMA TC 3	(2004) Standard for Polyvinyl Chloride PVC Fittings for Use With Rigid PVC Conduit and Tubing
NEMA WD 6	(2002; R 2008) Standard for Wiring Devices - Dimensional Requirements
NEMA Z535.1	(2006) Standard for Safety Colors
NATIONAL FIRE PROTECTION ASSOCIATION (NFPA)	
NFPA 70	(2007; AMD 1 2008) National Electrical Code - 2008 Edition
UNDERWRITERS LABORATORIES (UL)	
UL 1	(2005; Rev thru Jul 2007) Standard for Flexible Metal Conduit
UL 1242	(2006; Rev thru Jul 2007) Standard for Electrical Intermediate Metal Conduit -- Steel
UL 489	(2002; Rev thru Jun 2006) Standard for Molded-Case Circuit Breakers, Molded-Case Switches and Circuit-Breaker Enclosures
UL 6	(2007) Standard for Electrical Rigid Metal Conduit-Steel
UL 797	(2007) Standard for Electrical Metallic Tubing -- Steel
UL 870	(1995; Rev thru Jul 2003) Standard for Wireways, Auxiliary Gutters, and Associated Fittings

1.2 SUBMITTALS

Submit the following in accordance with Section 01 11 00 SPECIAL CONDITIONS, Paragraph 1.2:

SD-01 Preconstruction Submittals

Submit Material, Equipment, and Fixture Lists for the following:

Conduits, Raceway sand Fittings
Wire and Cable
Splices and Connectors
Switches
Receptacles
Outlets, Outlet Boxes, and Pull Boxes
Circuit Breakers
Panelboards

SD-03 Product Data

REPAIR AIRFIELD RAMP LIGHTS

Submit manufacturer's catalog data for the following items:

Conduits, Raceway and Fittings
Wire and Cable
Splices and Connectors
Switches
Receptacles
Outlets, Outlet Boxes, and Pull Boxes
Circuit Breakers
Panelboards
Spare Parts

Certification

Submittal for vertical assemblies will be reviewed by a licensed Mechanical, Civil or Structural Engineer to determine that the entire assembly will withstand 100 mph wind loading with a 1.3 gust factor.

SD-06 Test Reports

Continuity Test
Phase-Rotation Tests
Insulation Resistance Test

SD-08 Manufacturer's Instructions

Submit Manufacturer's Instructions.

1.3 PREVENTION OF CORROSION

Protect metallic materials against corrosion. Provide equipment enclosures with the standard finish by the manufacturer when used for most indoor installations. For harsh indoor environments (any area subjected to chemical and/or abrasive action), and all outdoor installations, refer to Section 09 96 00 HIGH-PERFORMANCE COATINGS. Do not use aluminum when in contact with earth or concrete and, where connected to dissimilar metal, protect by approved fittings and treatment. Ferrous metals such as, but not limited to, anchors, bolts, braces, boxes, bodies, clamps, fittings, guards, nuts, pins, rods, shims, thimbles, washers, and miscellaneous spare parts not of corrosion-resistant steel shall be hot-dip galvanized except where other equivalent protective treatment is specifically approved in writing.

1.4 DEFINITIONS

- a. Unless otherwise specified or indicated, electrical and electronics terms used in these specifications, and on the drawings, shall be as defined in IEEE Std 100.
- b. The technical sections referred to herein are those specification sections that describe products, installation procedures, and equipment operations and that refer to this section for detailed description of submittal types.
- c. Vertical assembly. A vertical assembly is a pole, tower or other such support, mounting hardware, arms, brackets and the load. Load can be a luminaire, siren, loudspeaker or other device. All

REPAIR AIRFIELD RAMP LIGHTS

components of a vertical assembly will be rated by the manufacturer to withstand 100 mph wind loading with a 1.3 gust factor.

1.5 GENERAL REQUIREMENTS

Submit Material, Equipment, and Fixture Lists for the following items showing manufacturer's style or catalog numbers, specification and drawing reference numbers, warranty information, and fabrication site.

Submit Manufacturer's Instructions including special provisions required to install equipment components and system packages. Special notices shall detail impedances, hazards and safety precautions.

Submit Certification required to install equipment components and system packages.

1.6 POSTED OPERATING INSTRUCTIONS

Provide for each system and principal item of equipment as specified in the technical sections for use by operation and maintenance personnel. The operating instructions shall include the following:

- a. Wiring diagrams, control diagrams, and control sequence for each principal system and item of equipment.
- b. Start up, proper adjustment, operating, lubrication, and shutdown procedures.
- c. Safety precautions.
- d. The procedure in the event of equipment failure.
- e. Other items of instruction as recommended by the manufacturer of each system or item of equipment.

Print or engrave operating instructions and frame under glass or in approved laminated plastic. Post instructions where directed. For operating instructions exposed to the weather, provide weather-resistant materials or weatherproof enclosures. Operating instructions shall not fade when exposed to sunlight and be secured to prevent easy removal or peeling.

1.7 MANUFACTURER'S NAMEPLATE

Each item of equipment shall have a nameplate bearing the manufacturer's name, address, model number, and serial number securely affixed in a conspicuous place; the nameplate of the distributing agent will not be acceptable.

1.8 FIELD FABRICATED NAMEPLATES

ASTM D 709. Provide laminated plastic nameplates for each equipment enclosure, relay, switch, and device; as specified in the technical sections or as indicated on the drawings. Each nameplate inscription shall identify the function and, when applicable, the position. Nameplates shall be melamine plastic, 0.125 inch thick, white with black center core. Surface shall be matte finish. Corners shall be square. Accurately align lettering and engrave into the core. Minimum size of nameplates shall be

REPAIR AIRFIELD RAMP LIGHTS

one by 2.5 inches. Lettering shall be a minimum of 0.25 inch high normal block style.

1.9 WARNING SIGNS

Provide warning signs for the enclosures of electrical equipment including substations, pad-mounted transformers, pad-mounted switches, generators, and switchgear having a nominal rating exceeding 600 volts.

- a. When the enclosure integrity of such equipment is specified to be in accordance with IEEE C57.12.28 or IEEE C57.12.29, such as for pad-mounted transformers and pad-mounted SF6 switches, provide self-adhesive warning signs on the outside of the high voltage compartment door(s). Sign shall be a decal and have nominal dimensions of 7 by 10 inches with the legend "DANGER HIGH VOLTAGE" printed in two lines of nominal 2 inch high letters. The word "DANGER" shall be in white letters on a red background and the words "HIGH VOLTAGE" shall be in black letters on a white background. Decal shall be Panduit No. PPS0710D72 or approved equal.
- b. When such equipment is guarded by a fence, mount signs on the fence. Provide metal signs having nominal dimensions of 14 by 10 inches with the legend "DANGER HIGH VOLTAGE KEEP OUT" printed in three lines of nominal 3 inch high white letters on a red and black field.

PART 2 PRODUCTS

2.1 MATERIALS

Materials and equipment to be provided shall be the standard cataloged products of manufacturers regularly engaged in the manufacture of the products.

2.1.1 Rigid Steel Conduit

Rigid steel conduit shall comply with UL 6 and be galvanized by the hot-dip process. Rigid steel conduit shall be polyvinylchloride (PVC) coated in accordance with NEMA RN 1, where underground and in corrosive areas, or must be painted with bitumastic.

Fittings for rigid steel conduit shall be threaded.

Gaskets shall be solid. Conduit fittings with blank covers shall have gaskets, except in clean, dry areas or at the lowest point of a conduit run where drainage is required.

Covers shall have captive screws and be accessible after the work has been completed.

2.1.2 Electrical Metallic Tubing (EMT)

EMT shall be in accordance with UL 797 and be zinc coated steel. Couplings and connectors shall be zinc-coated, raintight, gland compression with insulation throat. Crimp, spring, or setscrew type fittings are not acceptable.

REPAIR AIRFIELD RAMP LIGHTS

2.1.3 Flexible Metallic Conduit

Flexible metallic conduit shall comply with UL 1 and be galvanized steel.

Fittings for flexible metallic conduit shall be specifically designed for such conduit.

Provide liquidtight flexible metallic conduit with a protective jacket of PVC extruded over a flexible interlocked galvanized steel core to protect wiring against moisture, oil, chemicals, and corrosive fumes.

Specifically design fittings for liquidtight flexible metallic conduit for such conduit.

2.1.4 Intermediate Metal Conduit

Intermediate metal conduit shall comply with UL 1242 and be galvanized.

2.1.5 Rigid Nonmetallic Conduit

Rigid nonmetallic conduit shall comply with NEMA TC 2 and NEMA TC 3 with wall thickness not less than Schedule 40.

2.1.6 Wireways and Auxiliary Gutters

Wireway and auxiliary gutters shall be a minimum 4- by 4 inch trade size conforming to UL 870.

2.2 WIRE AND CABLE

Conductors installed in conduit shall be copper 600-volt type XHHW. All conductors AWG No. 8 and larger, shall be stranded. All conductors smaller than AWG No. 8 shall be solid.

Flexible cable shall be Type SO and contain a grounding conductor with green insulation.

Conductors installed in plenums shall be marked plenum rated.

2.3 SPLICES AND CONNECTORS

Make all splices in AWG No. 8 and smaller with approved indenter crimp-type connectors and compression tools.

Make all splices in AWG No. 6 and larger with indenter crimp-type connectors and compression tools. Joints shall be wrapped with an insulating tape that has an insulation and temperature rating equivalent to that of the conductor.

2.4 SWITCHES

2.4.1 Safety Switches

Safety switches shall comply with NEMA KS 1, and be the heavy-duty type with enclosure, voltage, current rating, number of poles, and fusing as indicated. Switch construction shall be such that, when the switch handle in the "ON" position, the cover or door cannot be opened. Cover release device shall be coinproof and be so constructed that an external tool shall be used to open the cover. Make provisions to lock the handle in the

REPAIR AIRFIELD RAMP LIGHTS

"OFF" position, but the switch shall not be capable of being locked in the "ON" position.

Provide switches of the quick-make, quick-break type. Approve terminal lugs for use with copper conductors.

Safety color coding for identification of safety switches shall conform to NEMA Z535.1.

2.4.2 Toggle Switches

Toggle switches shall comply with EIA 480, control incandescent, mercury, and fluorescent lighting fixtures and be of the heavy duty, general purpose, noninterchangeable flush-type.

Toggle switches shall be commercial grade toggle type, single-pole, two-position devices rated 20 amperes at 277 volts, 60 hertz alternating current (ac) only.

All toggle switches shall be products of the same manufacturer.

2.5 RECEPTACLES

Receptacles shall be commercial grade, 20A, 125 VAC, 2-pole, 3-wire duplex conforming to NEMA WD 6, NEMA 5-20R.

2.6 OUTLETS, OUTLET BOXES, AND PULL BOXES

Outlet boxes for use with conduit systems shall be in accordance with NEMA FB 1 and NEMA OS 1 and be not less than 1-1/2 inches deep. Furnish all pull and junction boxes with screw-fastened covers.

2.7 PANELBOARDS

Lighting and appliance branch circuit panelboards shall be the circuit-breaker type in accordance with NEMA PB 1. Bolt circuit breakers to the bus. Plug-in circuit breakers are not acceptable. Buses shall be copper of the rating indicated, with main lugs or main circuit breaker as indicated. Provide all panelboards for use on grounded ac systems with a full-capacity isolated neutral bus and a separate grounding bus bonded to the panelboard enclosure. Panelboard enclosures shall be NEMA 250, Type 4, in accordance with NEMA PB 1. Provide enclosure fronts with latchable hinged doors.

2.8 CIRCUIT BREAKERS

Circuit-breaker interrupting rating shall be calculated to exceed the available fault current and in no event less than 14,000 amperes root-mean-square (rms) symmetrical at 480 volts, respectively. Multipole circuit breakers shall be the common-trip type with a single handle. Molded case circuit breakers shall be bolt-on type conforming to UL 489.

2.9 LAMPS AND LIGHTING FIXTURES

Manufacturers and catalog numbers shown are indicative of the general type desired and are not intended to restrict the selection to fixtures of any particular manufacturer. Fixtures with the same salient features and equivalent light distribution and brightness characteristics, of equal finish and quality, are acceptable. Provide lamps of the proper type and

REPAIR AIRFIELD RAMP LIGHTS

wattage for each fixture.

Ballasts shall be high power factor and be energy efficient.

High intensity discharge (HID) lighting fixtures shall have prewired integral ballasts and cast aluminum housings complete with tempered glass lenses suitable for installation in damp or wet locations. Provide fixtures and lamps.

PART 3 EXECUTION

3.1 REPAIR OF EXISTING WORK

Repair of existing work, demolition, and modification of existing electrical distribution systems shall be preformed as follow:

3.1.1 Workmanship

Lay out work in advance. Exercise care where cutting, channeling, chasing, or drilling of floors, walls, partitions, ceilings, or other surfaces is necessary for proper installation, support, or anchorage of conduit, raceways, or other electrical work. Repair damage to buildings, piping, and equipment using skilled craftsmen of trades involved.

3.1.2 Existing Concealed Wiring to be Removed

Existing concealed wiring to be removed shall be disconnected from its source. Remove conductors; cut conduit flush with floor, underside of floor, and through walls; and seal openings.

3.1.3 Removal of Existing Electrical Distribution System

Removal of existing electrical distribution system equipment shall include equipment's associated wiring, including conductors, cables, exposed conduit, surface metal raceways, boxes, and fittings, back to equipment's power source or as indicated.

3.1.4 Continuation of Service

Maintain continuity of existing circuits of equipment to remain. Existing circuits of equipment shall remain energized. Circuits which are to remain but were disturbed during demolition shall have circuits wiring and power restored back to original condition.

3.2 CONDUITS, RACEWAYS AND FITTINGS

Conduit runs between outlet and outlet, between fitting and fitting, or between outlet and fitting shall not contain more than the equivalent of three 90-degree bends, including those bends located immediately at the outlet or fitting.

Do not install crushed or deformed conduit. Avoid trapped conduit runs where possible. Take care to prevent the lodgment of foreign material in the conduit, boxes, fittings, and equipment during the course of construction. Clear any clogged conduit of obstructions or be replaced.

Conduit and raceway runs concealed in or behind walls, above ceilings, or exposed on walls and ceilings 5 feet or more above finished floors and not subject to mechanical damage may be electrical metallic tubing (EMT).

REPAIR AIRFIELD RAMP LIGHTS

3.2.1 Rigid Steel Conduit

Make field-made bends and offsets with approved hickey or conduit bending machine. Conduit elbows larger than 2-1/2 inches shall be long radius.

Provide all conduit stubbed-up through concrete floors for connections to free-standing equipment with the exception of motor-control centers, cubicles, and other such items of equipment, with a flush coupling when the floor slab is of sufficient thickness. Otherwise, provide a floor box set flush with the finished floor. Conduits installed for future use shall be terminated with a coupling and plug set flush with the floor.

3.2.2 Electrical Metallic Tubing (EMT)

EMT shall be grounded in accordance with NFPA 70, using pressure grounding connectors especially designed for EMT.

3.2.3 Flexible Metallic Conduit

Use flexible metallic conduit to connect recessed fixtures from outlet boxes in ceilings, transformers, and other approved assemblies.

Bonding wires shall be used in flexible conduit as specified in NFPA 70, for all circuits. Flexible conduit shall not be considered a ground conductor.

Electrical connections to vibration-isolated equipment shall be made with flexible metallic conduit.

Liquidtight flexible metallic conduit shall be used in wet and oily locations and to complete the connection to motor-driven equipment.

3.2.4 Intermediate Conduit

Make all field-made bends and offsets with approved hickey or conduit bending machine. Use intermediate metal conduit only for indoor installations.

3.2.5 Rigid Nonmetallic Conduit

Rigid PVC conduit shall be installed per 33 70 02. 00 10 Electrical Distribution System, underground.

A green insulated copper grounding conductor shall be in conduit with conductors and be solidly connected to ground at each end. Grounding wires shall be sized in accordance with NFPA 70.

3.2.6 Wireway and Auxiliary Gutter

Straight sections and fittings shall be bolted together to provide a rigid, mechanical connection and electrical continuity. Dead ends of wireways and auxiliary gutters shall be closed. Plug all unused conduit openings.

Auxiliary gutters used to supplement wiring spaces for equipment not contained in a single enclosure shall contain no switches, overcurrent devices, appliances, or apparatus and be not more than 4 feet long.

REPAIR AIRFIELD RAMP LIGHTS

3.3 WIRING

Conductors up to and including AWG No. 2 shall be manufactured with colored insulating materials. Conductors larger than AWG No. 2 shall have ends identified with color plastic tape in outlet, pull, or junction boxes.

Splice in accordance with the NFPA 70. Provide conductor identification within each enclosure where a tap, splice, or termination is made and at the equipment terminal of each conductor. Terminal and conductor identification shall match as indicated.

Where several feeders pass through a common pullbox, the feeders shall be tagged to clearly indicate the electrical characteristics, circuit number, and panel designation.

3.4 SAFETY SWITCHES

Securely fasten switches to the supporting structure or wall, utilizing a minimum of four 1/4 inch bolts. Do not use sheet metal screws and small machine screws for mounting. Do not mount switches in an inaccessible location or where the passageway to the switch may become obstructed. Mounting height shall be 5 feet above floor level, when possible.

3.5 WIRING DEVICES

3.5.1 Wall Switches and Receptacles

Install wall switches and receptacles so that when device plates are applied, the plates will be aligned vertically to within 1/16 inch.

Ground terminal of each flush-mounted receptacle shall be bonded to the outlet box with an approved green bonding jumper when used with dry wall type construction.

3.5.2 Device Plates

Device plates for switches that are not within sight of the loads controlled shall be suitably engraved with a description of the loads.

Device plates and receptacle cover plates for receptacles other than 125-volt, single-phase, duplex, convenience outlets shall be suitably marked, showing the circuit number, voltage, frequency, phasing, and amperage available at the receptacle. Required marking shall consist of a self-adhesive label having 1/4 inch embossed letters.

Device plates for convenience outlets shall be similarly marked indicating the supply panel and circuit number.

3.6 PANELBOARDS

Securely mount panelboards so that the top operating handle does not exceed 72-inches above the finished floor. Do not mount equipment within 36 inches of the front of the panel. Directory card information shall be complete and legible.

3.7 IDENTIFICATION PLATES AND WARNINGS

Furnish and install identification plates for lighting and power panelboards, motor control centers, all line voltage heating and

REPAIR AIRFIELD RAMP LIGHTS

ventilating control panels, fire detector and sprinkler alarms, door bells, pilot lights, disconnect switches, manual starting switches, and magnetic starters. Process control devices and pilot lights shall have identification plates.

Furnish identification plates for all line voltage enclosed circuit breakers, identifying the equipment served, voltage, phase(s) and power source. Circuits 480 volts and above shall have conspicuously located warning signs in accordance with OSHA requirements.

3.8 PAINTING

Exposed conduit, supports, fittings, cabinets, pull boxes, and racks shall be thoroughly cleaned and painted as specified in Section 09 96 00 HIGH-PERFORMANCE COATINGS.

3.9 FIELD TESTING

Submit Test Reports in accordance with referenced standards in this section.

After completion of the installation and splicing, and prior to energizing the conductors, perform wire and cable continuity and insulation tests as herein specified before the conductors are energized.

Contractor shall provide all necessary test equipment, labor, and personnel to perform the tests, as herein specified.

Isolate completely all wire and cable from all extraneous electrical connections at cable terminations and joints. Substation and switchboard feeder breakers, disconnects in combination motor starters, circuit breakers in panel boards, and other disconnecting devices shall be used to isolate the circuits under test.

Perform Insulation-Resistance Test on each field-installed conductor with respect to ground and adjacent conductors. Applied potential shall be 500 volts dc for 300 volt rated cable and 1000 volts dc for 600 volt rated cable. Take readings after 1 minute and until the reading is constant for 15 seconds. Minimum insulation-resistance values shall not be less than 25 Megohms for 300 volt rated cable and 100 Megohms for 600 volt rated cable. For circuits with conductor sizes 8AWG and smaller insulation resistance testing is not required.

Perform Continuity Test to insure correct cable connection (i.e correct phase conductor, grounded conductor, and grounding conductor wiring) end-to-end. Any damages to existing or new electrical equipment resulting from contractor mis-wiring will be repaired and re-verified at contractor's expense. All repairs shall be approved by the CO prior to acceptance of the repair.

Conduct Phase-Rotation Tests on all three-phase circuits using a phase-rotation indicating instrument. Perform phase rotation of electrical connections to connected equipment clockwise, facing the source.

Final acceptance will depend upon the successful performance of wire and cable under test. Do not energize any conductor until the final test reports are reviewed and approved by the CO.

-- End of Section --

BLANK PAGE

REPAIR AIRFIELD RAMP LIGHTS

SECTION 26 09 23.00 40

LIGHTING CONTROL DEVICES

11/08

PART 1 GENERAL

1.1 REFERENCES

The publications listed below form a part of this specification to the extent referenced. The publications are referred to within the text by the basic designation only.

ILLUMINATING ENGINEERING SOCIETY OF NORTH AMERICA (IESNA)

IESNA LM-48 (2001) Guide for Calibration of Photoelectric Control Devices

NATIONAL ELECTRICAL MANUFACTURERS ASSOCIATION (NEMA)

NEMA ICS 1 (2000; R 2005; R 2008) Standard for Industrial Control and Systems General Requirements

NEMA ICS 2 (2000; Errata 2002; R 2005; Errata 2006) Standard for Industrial Control and Systems: Controllers, Contractors, and Overload Relays Rated Not More than 2000 Volts AC or 750 Volts DC: Part 8 - Disconnect Devices for Use in Industrial Control Equipment

NEMA ICS 6 (1993; R 2006) Standard for Industrial Controls and Systems Enclosures

UNDERWRITERS LABORATORIES (UL)

UL 773 (1995; Rev thru Mar 2002) Standard for Plug-In Locking Type Photocontrols for Use with Area Lighting

UL 773A (2006) Nonindustrial Photoelectric Switches for Lighting Control

1.2 GENERAL REQUIREMENTS

Submit Installation Drawings for light-sensitive control devices in accordance with the manufacturer's recommended instructions for installation.

1.3 SUBMITTALS

Submit the following in accordance with Section 01 11 00 SPECIAL CONDITIONS, Paragraph 1.2:

SD-03 Product Data

Submit manufacturer's catalog data for Photoconductive Control

REPAIR AIRFIELD RAMP LIGHTS

Devices.

Submit Installation Drawings for Light-Sensitive Control Devices in accordance with paragraph entitled, "General Requirements," of this section.

Switches; G

Fuses; G

Light Level Sensor; G

Lighting Contactor; G

Photocell Switch; G

Fiber Optic Equipment and Accessories; G

SD-06 Test Reports

Submit test reports for System Operation Tests in the presence of the Contracting Officer.

SD-08 Manufacturer's Instructions

Submit operational instructions for Light-Sensitive Control Devices consisting of the manufacturer's recommended procedures for operation.

SD-10 Operation and Maintenance Data

Lighting Control System, Data Package 5; G

1.4 QUALITY ASSURANCE

Personel installing Fiber Optic equipment, cable, and accessories shall be BKSI Registered Telecommunications Installers. Installation shall comply with Section 27 10 10 "Langley Air Force Base Telecommunications Building Cabling Systems Standards."

PART 2 PRODUCTS

2.1 PHOTOCONDUCTIVE CONTROL DEVICES

Provide photoconductive control devices in accordance with UL 773. Control lighting luminaires in banks by a single photo-control element mounted at each control enclosure. Mold housing for light-sensitive control devices from translucent butyrate or acrylic plastic materials and fasten to the base with screws. Provide physically and electrically interchangeable light sensitive control devices with three-pole, 3-wire locking plug and receptacle connections to the line, load, and neutral conductors of the lighting circuit.

Provide photoconductive control devices for natural daylight and darkness control of outdoor lighting luminaires including a photoconductive cell, thermal actuator, and snap-action switch in a weatherproof housing. Provide a control device which is, when attached to its mounting, weatherproof and constructed to exclude beating rain, snow, dust, and insects and capable of withstanding 96 percent relative humidity at 122

REPAIR AIRFIELD RAMP LIGHTS

degrees F for 48 hours under operating conditions.

Submit operation and maintenance data, Lighting Control System, Data Package 5, in accordance with Section 01 78 23 OPERATION AND MAINTENANCE DATA and as specified herein, showing all light fixtures, control modules, control zones, light level sensors, power packs, schematic diagrams and all interconnecting control wire, conduit, and associated hardware.

2.1.1 Photoconductive Limit Settings

Provide device which turns on within the limits of plus 100 to minus 50 percent of its setting, over a range of input voltage from 105 to 130 volts at rated frequency and ambient temperature, and at rated voltage and frequency over a range of temperature from minus 85 to 122 degrees F, with relative humidities up to 96-percent throughout the temperature range.

Adjust the device to operate within the limits of 0.8 to 1.2 foot-candles, but also capable of calibration of the turn-on light level over a minimum range from 0.5 to 3.0 foot-candles, and adaptable for calibration up to 10 foot-candles. Ratio of turn-off light level to turn-on light level is not to exceed 5.

2.1.2 Device Rating and Accuracy

Rate the devices at 120 or 277 volts, 60 hertz, with rated ambient temperature of 77 plus or minus 41 degrees F

Maintain instrument accuracy by proper calibration in accordance with IESNA LM-48.

2.2 LIGHTING CONTACTOR

Provide NEMA ICS 2, mechanically held contactor, rated 480 volts, 60 amperes, and 4 poles, with coils rated 120 volts. Provide in NEMA 4x stainless steel enclosure conforming to NEMA ICS 6. Provide contactor with silver alloy double-break contacts and coil clearing contacts for mechanically held contactor requiring no arcing contacts. Provide contactor with hand-off-automatic selector switch.

Assembly Combination Lighting Control Enclosure shall be UL 508, NEMA ICS 1, and NEMA ICS 2. Controllers shall have thermal overload protection in each phase and shall have one spare normally open and one spare normally closed auxiliary contact. Controller shall have hand/off/automatic selector switch. Connections to selector switch shall be such that only normal automatic regulatory control devices are bypassed when switch is in "hand" position. Safety control devices shall be connected in motor control circuit in "hand" and "automatic" positions. Control circuit connections to hand/off/automatic selector switch or to more than one automatic regulatory control device shall be made in accordance with indicated or manufacturer's approved wiring diagram. Selector switch shall have means for locking in any position. Cover of controller switch shall be interlocked with operating handle of switch so that cover cannot be opened unless handle of switch is in "off" position. Minimum short circuit withstand rating of combination motor controller shall be sized to exceed the calculated available fault current at the installed location.

2.2.1 Control Wiring

All control wire shall be stranded tinned copper switchboard wire with

REPAIR AIRFIELD RAMP LIGHTS

600-volt flame-retardant insulation Type SIS meeting UL 44, or Type MTW meeting UL 1063, and shall pass the VW-1 flame tests included in those standards. Hinge wire shall have Class K stranding. The minimum size of control wire shall be No. 14 AWG. Power wiring for 480-volt circuits and below shall be of the same type as control wiring and the minimum size shall be No. 12 AWG. Special attention shall be given to wiring and terminal arrangement on the terminal blocks to permit the individual conductors of each external cable to be terminated on adjacent terminal points.

2.2.2 Control Circuit Terminal Blocks

NEMA ICS 4. Control circuit terminal blocks for control wiring shall be molded or fabricated type with barriers, rated not less than 600 volts. The terminals shall be removable binding, fillister or washer head screw type, or of the stud type with contact and locking nuts. The terminals shall be not less than No. 10 in size and shall have sufficient length and space for connecting at least two indented terminals for 10 AWG conductors to each terminal. The terminal arrangement shall be subject to the approval of the Contracting Officer and not less than four (4) spare terminals or 10 percent, whichever is greater, shall be provided on each block or group of blocks. Modular, pull apart, terminal blocks will be acceptable provided they are of the channel or rail-mounted type. The Contractor shall submit data showing that the proposed alternate will accommodate the specified number of wires, are of adequate current-carrying capacity, and are constructed to assure positive contact between current-carrying parts.

2.2.3 Control Circuits

Control circuits shall have maximum voltage of 120 volts derived from control transformer in same enclosure. Transformers shall conform to UL 506, as applicable. Transformers, other than transformers in bridge circuits, shall have primaries wound for voltage available and secondaries wound for correct control circuit voltage. Size transformers so that 80 percent of rated capacity equals connected load. Provide disconnect switch on primary side. Provide fuses in each ungrounded primary feeder. One secondary lead shall be fused; other shall be grounded.

2.2.4 Pilot and Indicating Lights

Provide LED cluster lamps.

2.3 PHOTOCCELL SWITCH

Provide photocell switch conforming to UL 773 or UL 773A, hermetically sealed cadmium-sulfide or silicon diode type cell rated 120 volts ac, 60 Hz with single pole double-throw (spdt) contacts for mechanically held contactors rated 1000 watts designed to fail to the ON position. Provide switch which turns on at or below 3 footcandles and off at 4 to 10 footcandles. Provide time delay to prevent accidental switching from transient light sources. Provide a directional lens in front of the cell to prevent fixed light sources from creating a turnoff condition. Provide switch:

- a. In a U.V. stabilized polycarbonate housing with swivel arm and adjustable window slide, rated 1800 VA, minimum.

REPAIR AIRFIELD RAMP LIGHTS

2.4 FIBER OPTIC EQUIPMENT AND ACCESSORIES

2.4.1 Rack Mountable Card Chassis

1. Chassis system shall be compatible with standard EIA 19" electronic equipment mounting systems and be 4RU (7 inches) in height.
2. Side mounting rails shall be capable of mounting on the front or rear of the chassis.
3. The chassis shall have 21 slots and be capable of holding up to two power supplies, leaving 18 slots available with one power supply installed and 15 slots available with two power supplies installed.
4. The unit must be capable of operation over a temperature range of -40 degrees C to +74 degrees C and 0% to 95% non-condensing humidity.
5. Chassis shall permit the installation or removal of cards with the power applied without affecting other cards in the chassis.
6. The chassis shall support a software management system for monitoring and maintenance purposes.
7. The chassis shall include three monitoring LED's:
 - a. Power: Illuminate green if all installed power supplies are operating within prescribed limits. Illuminate red if any power supply has an out of tolerance condition.
 - b. System: Illuminate green if none of the functioning cards in the chassis have a fault. Fault condition shall be indicated to the system chassis by an open collector alarm circuit on each installed card. Illuminates red if any card displays a fault.
 - c. Network: Blinks when an installed poll response network card is polled by the management system.
8. Power Supply:
 - a. Input: 100-240 VAC at 50 to 60 Hz.
 - b. Output: 6 VDC, current output shall be sufficient to supply all installed cards plus 25%.
 - c. Power supply DC output shall be isolated by Schottky diode.
 - d. Power supply shall include contact closure alarm when the voltage output is out of specified range.
9. Rack shall be cooled by vertical flow-through ventilation.

2.4.2 Miniature 2-Card Chassis

1. Miniature chassis shall have two slots capable of accepting standard 4 RU (7 inch) cards.
2. Chassis shall be powered by an external 6 VDC, 2 amp power supply.
3. Chassis and cards shall be capable of operation over a temperature

REPAIR AIRFIELD RAMP LIGHTS

range of -40 degrees C to +74 degrees C and 0% to 95% non-condensing humidity.

4. Chassis shall permit the installation or removal of cards with the power applied without affecting other cards in the chassis.

5. The chassis shall support a software management system for monitoring and maintenance purposes.

6. The chassis shall be able to mount to a backpanel or other flat surface within another enclosure without inhibiting the installation or removal of cards.

2.4.3 Discrete Signal Mux/DeMux

1. One Mux shall be installed in the Air Operations Building. Coordinate with Langley DOIM.

2. One DeMux shall be installed in each High Mast Lighting Control Enclosure.

3. Multiplexer (Mux) card shall transport up to eight bi-directional data or contact closure signals via one optical fiber.

4. Unit shall rack mount in 19 inch chassis using one or two slots.

5. Mux shall accept up to eight contact closure signals, transport into a single mode fiber optic signal. DeMux shall receive singlemode fiber optic signal and transport back into original contact closure configuration.

6. Unit shall be powered by 6 VDC from the chassis back plane.

7. The Mux/Demux shall be singlemode with an optical budget of 25 dB at 1310 and 1550 nm.

8. Range for single mode fiber shall be greater than or equal to 50 km.

9. The card must be capable of operation over a temperature range of -40 degrees C to +74 degrees C and 0% to 95% non-condensing humidity.

10. The card shall include status indication for loop, sync, and power.

2.4.4 High Mast Lighting Control

Stand Alone Optical Start Transceiver

1. Unit shall have manufacturer's standard enclosure with standard shelf.

2. Transceiver shall operate over a temperature range of - 34 degrees C to + 74 degrees C and 0 percent to 95 percent non-condensing humidity.

3. The transceiver shall support a software management system for monitoring and maintenance purposes.

4. The transceiver shall support full or half duplex, a synchronous

REPAIR AIRFIELD RAMP LIGHTS

RS-232, RS-422, and RS-485 data transmission.

5. The transceiver shall include at least three monitoring LED's.

a. Power: Illuminate green if all operations of the power supply are within the prescribed limits.

b. Data: TXD or RXD shall illuminate when data is being transmitted or received.

6. Power Supply:

a. Input: 100-120 volts AC, 50 to 60 Hz.

b. Output: 9 volts DC.

7. Unit shall be cooled by vertical flow-through ventilation.

2.5 DISCONNECT SWITCHES

NEMA KS 1. Provide heavy duty-type switches. Fused switches shall utilize Class R fuseholders and fuses, unless indicated otherwise. Provide switches in the NEMA 4x SS Lighting Contractor, enclosure per NEMA ICS 6.

2.6 FUSES

NEMA FU 1. Provide complete set of fuses for each fusible switch. Time-current characteristics curves of fuses serving motors or connected in series with circuit breakers or other circuit protective devices shall be coordinated for proper operation. Submit coordination data for approval. Fuses shall have voltage rating not less than circuit voltage.

2.6.1 Fuseholders

Provide in accordance with UL 512.

2.6.2 Cartridge Fuses, Current Limiting Type (Class R)

UL 198M, Class RK-5 time-delay type. Associated fuseholders shall be Class R only.

Where fuse protection is specifically recommended by the equipment manufacturer, provide fused switches in lieu of non-fused switches indicated.

2.7 EQUIPMENT IDENTIFICATION

2.7.1 Manufacturer's Nameplate

Provide each item of equipment with a nameplate bearing the manufacturer's name, address, model number, and serial number securely affixed in an inconspicuous place; the nameplate of the distributing agent is not acceptable.

2.7.2 Labels

Provide labeled control devices, clearly marked for operation of specific lighting functions according to type. Note the following devices characteristics in the format "Use Only _____":

REPAIR AIRFIELD RAMP LIGHTS

Make markings related to control device type clear and locate to be readily visible to service personnel, but unseen from normal viewing angles when devices are in place.

Label fiber optic cable equipment conforming to ANSI/TIA/EIA-606 (A) standards and Section 27 10 10 "Langley Air Force Base Telecommunications Building Cabling System Standards." In addition, provide the following:

Labels shall be machine-printed. Hand-lettered labels shall not be acceptable.

Provide detailed wiring plans showing locations, type, and cable marking of all cables.

PART 3 EXECUTION

3.1 INSTALLATION

3.1.1 Photoconductive Control Devices

Install control devices in accordance with the manufacturer's installation instructions.

3.1.2 Magnetic Contactors

Provide magnetic contactors mechanically held, electrically operated, conforming to NEMA ICS 1 and NEMA ICS 2, suitable for 480 volts, 3 phase, 60 Hz, with coil voltage of 120 volts. Provide with maximum continuous ampere rating and number of poles as indicated on drawings. Provide enclosures for contactors mounted outdoors conforming to NEMA ICS 6, Type 4x stainless steel. Provide each contactor with a spare, normally open auxiliary contact.

Coordinate terminal lugs with the wire size. Securely fasten switches to the supporting structure or wall using not less than four 1/4 inch bolts. The use of sheet metal screws is not allowed.

3.2 FIELD TESTING

Demonstrate that photoconductive control devices operate satisfactorily in the presence of the Contracting Officer.

Perform System Operation Tests in accordance with referenced standards in this section.

3.3 TESTING

Test optical cable with a light source and power meter utilizing procedures as stated in ANSI/TIA/EIA-526-14A: OFSTP-14A Optical Power Loss Measurements of Installed Multimode Fiber Cable Plant and ANSI/TIA/EIA-526-7 Measurement of Optical Power Loss of Installed Singlemode Fiber Cable Plant. Measured results shall be plus/minus 1 dB of submitted loss budget calculations. If loss figures are outside this range, test cable with optical time domain reflectometer to determine cause of variation. Correct improper splices and replace damaged cables.

Where any portion of system does not meet the specifications, correct

REPAIR AIRFIELD RAMP LIGHTS

deviation and repeat applicable testing at no additional cost to the Contracting Officer.

-- End of Section --

BLANK PAGE

REPAIR AIRFIELD RAMP LIGHTS

SECTION 26 56 00

EXTERIOR LIGHTING

07/06

PART 1 GENERAL

1.1 REFERENCES

The publications listed below form a part of this specification to the extent referenced. The publications are referred to in the text by the basic designation only.

AMERICAN ASSOCIATION OF STATE HIGHWAY AND TRANSPORTATION OFFICIALS
(AASHTO)

AASHTO LTS (2001; Am 2002, Am 2003, Am 2006) Standard Specifications for Structural Supports for Highway Signs, Luminaires and Traffic Signals

ASTM INTERNATIONAL (ASTM)

ASTM A 153/A 153M (2005) Standard Specification for Zinc Coating (Hot-Dip) on Iron and Steel Hardware

ILLUMINATING ENGINEERING SOCIETY OF NORTH AMERICA (IESNA)

IESNA HB-9 (2000; Errata 2004; Errata 2005) IES Lighting Handbook

INSTITUTE OF ELECTRICAL AND ELECTRONICS ENGINEERS (IEEE)

IEEE C2 (2007; Errata 2007; INT 2008) National Electrical Safety Code

IEEE Std 100 (2000) The Authoritative Dictionary of IEEE Standards Terms

NATIONAL ELECTRICAL MANUFACTURERS ASSOCIATION (NEMA)

NEMA 250 (2003) Enclosures for Electrical Equipment (1000 Volts Maximum)

NEMA C136.10 (2006) American National Standard for Roadway Lighting Equipment-Locking-Type Photocontrol Devices and Mating Receptacles - Physical and Electrical Interchangeability and Testing

NEMA C78.43 (2007) Standard for Electric Lamps - Single-Ended Metal-Halide Lamps

NEMA C82.4 (2002) Ballasts for High-Intensity-Discharge and Low-Pressure Sodium Lamps (Multiple-Supply Type)

REPAIR AIRFIELD RAMP LIGHTS

NEMA ICS 2 (2000; Errata 2002; R 2005; Errata 2006)
Standard for Industrial Control and
Systems: Controllers, Contractors, and
Overload Relays Rated Not More than 2000
Volts AC or 750 Volts DC: Part 8 -
Disconnect Devices for Use in Industrial
Control Equipment

NEMA ICS 6 (1993; R 2006) Standard for Industrial
Controls and Systems Enclosures

NATIONAL FIRE PROTECTION ASSOCIATION (NFPA)

NFPA 70 (2007; AMD 1 2008) National Electrical
Code - 2008 Edition

UNDERWRITERS LABORATORIES (UL)

UL 1029 (1994; Rev thru Dec 2007) Standard for
Safety High-Intensity-Discharge Lamp
Ballasts

UL 1598 (2008; Rev thru Nov 2008) Luminaires

UL 773 (1995; Rev thru Mar 2002) Standard for
Plug-In Locking Type Photocontrols for Use
with Area Lighting

UL 773A (2006) Nonindustrial Photoelectric
Switches for Lighting Control

1.2 DEFINITIONS

- a. Unless otherwise specified or indicated, electrical and electronics terms used in these specifications, and on the drawings, shall be as defined in IEEE Std 100.
- b. Average life is the time after which 50 percent will have failed and 50 percent will have survived under normal conditions.
- c. Groundline section is that portion between one foot above and 2 feet below the groundline.

1.3 SUBMITTALS

Submit the following in accordance with Section 01 11 00 SPECIAL
CONDITIONS, Paragraph 1.2:

SD-02 Shop Drawings

Luminaire drawings; G

Luminaire Mounting Frame; G

Lowering Device Assembly; G

Poles; G

SD-03 Product Data

REPAIR AIRFIELD RAMP LIGHTS

Energy Efficiency; G

Luminaires; G

Lamps; G

Ballasts; G

Lighting contactor; G

Photocell switch; G

Steel poles; G

Brackets

SD-05 Design Data

Design Data for luminaires; G

Lighting Calculations; G

SD-06 Test Reports

Operating test

Submit operating test results as stated in paragraph entitled "Field Quality Control."

SD-08 Manufacturer's Instructions

Poles

Submit instructions prior to installation.

SD-10 Operation and Maintenance Data

Operational Service

Submit documentation that includes contact information, summary of procedures, and the limitations and conditions applicable to the project. Indicate manufacturer's commitment to reclaim materials for recycling and/or reuse.

1.4 QUALITY ASSURANCE

1.4.1 Drawing Requirements

1.4.1.1 Luminaire Drawings

Include dimensions, effective projected area (EPA), accessories, and installation and construction details. Photometric data, including zonal lumen data, average and minimum ratio, aiming diagram, and computerized candlepower distribution data shall accompany shop drawings.

1.4.1.2 Poles

Include dimensions, wind load determined in accordance with AASHTO LTS,

REPAIR AIRFIELD RAMP LIGHTS

pole deflection, pole class, and other applicable information.

1.4.2 Design Data for Luminaires

- a. Distribution data according to IESNA classification type as defined in IESNA HB-9.
- b. Computerized horizontal illumination levels in footcandles at ground level, taken every 10 feet. Include average maintained footcandle level and maximum and minimum ratio.
- c. Amount of shielding on luminaires.

1.4.3 Lighting Calculations

- a. Provide light level calculations to demonstrate that the required exterior levels are met.
- b. Provide a site plan of the east and west apron which indicates the calculated light level. The site plan shall indicate lighting levels on a grid system at 20 foot intervals.
- c. Calculations shall be generated utilizing the fixtures, poles and placement in the submitted product data.
- d. Lighting level calculations shall indicate maintained (not initial) footcandle levels.
- e. The minimum exterior lighting level for the east apron shall be 0.4 footcandles, with a maintained average light level of 1.0 footcandle and a maximum-to-average uniformity ratio of 4.0 or less. The minimum light level for the west apron shall be 0.3 footcandles, with a maintained average light level of 0.7 footcandles and a uniformity ratio of 4.0 or less.

1.4.4 Regulatory Requirements

In each of the publications referred to herein, consider the advisory provisions to be mandatory, as though the word, "shall" had been substituted for "should" wherever it appears. Interpret references in these publications to the "authority having jurisdiction," or words of similar meaning, to mean the Contracting Officer. Equipment, materials, installation, and workmanship shall be in accordance with the mandatory and advisory provisions of NFPA 70 unless more stringent requirements are specified or indicated.

1.4.5 Standard Products

Provide materials and equipment that are products of manufacturers regularly engaged in the production of such products which are of equal material, design and workmanship. Products shall have been in satisfactory commercial or industrial use for 2 years prior to bid opening. The 2-year period shall include applications of equipment and materials under similar circumstances and of similar size. The product shall have been on sale on the commercial market through advertisements, manufacturers' catalogs, or brochures during the 2-year period. Where two or more items of the same class of equipment are required, these items shall be products of a single manufacturer; however, the component parts of the item need not be the products of the same manufacturer unless stated in this section.

REPAIR AIRFIELD RAMP LIGHTS

1.4.5.1 Alternative Qualifications

Products having less than a 2-year field service record will be acceptable if a certified record of satisfactory field operation for not less than 6000 hours, exclusive of the manufacturers' factory or laboratory tests, is furnished.

1.4.5.2 Material and Equipment Manufacturing Date

Products manufactured more than 3 years prior to date of delivery to site shall not be used, unless specified otherwise.

1.5 DELIVERY, STORAGE, AND HANDLING

1.5 Steel Poles

Do not store poles on ground. Support poles so they are at least one foot above ground level and growing vegetation. Do not remove factory-applied pole wrappings until just before installing pole.

1.6 WARRANTY

The equipment items shall be supported by service organizations which are reasonably convenient to the equipment installation in order to render satisfactory service to the equipment on a regular and emergency basis during the warranty period of the contract.

PART 2 PRODUCTS

2.1 PRODUCT COORDINATION

Products and materials not considered to be lighting equipment or lighting fixture accessories are specified in Section 33 70 02.00 10 ELECTRICAL DISTRIBUTION SYSTEM, UNDERGROUND.

2.2 LUMINAIRES

UL 1598. Provide luminaires as indicated. Provide luminaires complete with lamps of number, type, and wattage indicated. Details, shapes, and dimensions are indicative of the general type desired, but are not intended to restrict selection to luminaires of a particular manufacturer. Luminaires of similar designs, light distribution and brightness characteristics, and of equal finish and quality will be acceptable as approved.

2.2.1 Lamps

2.2.1.1 Metal-Halide Lamps

Provide luminaires with prismatic tempered glass lens.

a. Single-ended, wattage as indicated, conforming to NEMA C78.43

Lamps shall have Luminaire Efficiency Ratings (LER) as follows:

a. Upward efficiency of 0%

1. 1000+ watts: minimum 77 LER for closed fixture

REPAIR AIRFIELD RAMP LIGHTS

b. Upward efficiency of 1%-10%

1. 1000+ watts: minimum 88 LER for open fixture

2.2.2 Ballasts for High-Intensity-Discharge (HID) Luminaires

UL 1029 and NEMA C82.4, and shall be constant wattage autotransformer (CWA) or regulator, high power-factor type (minimum 90%). Provide single-lamp ballasts which shall have a minimum starting temperature of minus 30 degrees C. Ballasts shall be:

- a. Designed to operate on voltage system to which they are connected.
- b. Constructed so that open circuit operation will not reduce the average life.

HID ballasts shall have a solid-state igniter/starter with an average life in the pulsing mode of 10,000 hours at the intended ambient temperature. Igniter case temperature shall not exceed 90 degrees C.

2.3 LIGHTING CONTACTOR

NEMA ICS 2, mechanically held contactor. Contacts shall be rated 480 volts, 60 amperers. Rate contactor as indicated. Provide in NEMA 4x stainless steel enclosure conforming to NEMA ICS 6. Contactor shall have silver alloy double-break contacts and coil clearing contacts for mechanically held contactor and shall require no arcing contacts. Provide contactor with hand-off-automatic selector switch.

2.4 PHOTOCELL SWITCH

UL 773 or UL 773A, hermetically sealed cadmium-sulfide or silicon diode type cell single pole double-throw (spdt) contacts for mechanically held contactors rated 1000 watts designed to fail to the ON position. Switch shall turn on at or below 3 footcandles and off at 4 to 10 footcandles. A time delay shall prevent accidental switching from transient light sources. Provide a directional lens in front of the cell to prevent fixed light sources from creating a turnoff condition. Provide switch:

- a. In a high-impact-resistant, noncorroding and nonconductive molded plastic housing with a locking-type receptacle conforming to NEMA C136.10 and rated 1800 VA, minimum.

2.5 POLES

Provide poles designed for wind loading of 100 miles per hour determined in accordance with AASHTO LTS while supporting luminaires and all other appurtenances indicated. The effective projected areas of luminaires and appurtenances used in calculations shall be specific for the actual products provided on each pole. Poles shall be anchor-base type designed for use with underground supply conductors. Poles shall have oval-shaped handhole having a minimum clear opening of 2.5 by 5 inches. Handhole cover shall be secured by stainless steel captive screws. Metal poles shall have an internal grounding connection accessible from the handhole near the bottom of each pole. Scratched, stained, chipped, or dented poles shall not be installed.

REPAIR AIRFIELD RAMP LIGHTS

2.5.1 Steel Poles for High Mast Lighting

2.5.1.1 High Mast Poles

- a. Structural characteristics shall comply with AASHTO LTS-4. Poles shall be designed for wind loading of 100 mph with a gust factor of 1.3.
- b. The pole shaft shall be round or 16 sided polygon in cross section and shall be fabricated of high strength steel with a minimum yield strength of 50,000 psi and conforming to the requirements of ASTM A 572. Material of greater than 50,000 psi may be used, but only 50,000 psi may be used in the pole calculations. All material shall be a single thickness steel plate with no laminations. The pole shaft shall be cold formed and shall have not more than two longitudinal 60% penetration welds and no circumferential welds. Each section shall be uniformly tapered and shall be joined to form the pole shaft assembly be telescoping over the next lower section a minimum of 1.5 times the outside diameter of the top of the lower section.
- c. The base plate shall be a cold formed ring of steel with a yield strength of 50,000 psi before forming. The base plate shall be 2 inches thick by 5 inches wide minimum and be drilled for the required anchor bolts. The surface around each hole shall be milled flat and smooth to receive the anchor bolt nut. Flame cutting of the base plate shall not be allowed.
- d. The pole shaft shall be fitted with an integral base fabricated of formed panels assembled by a means of longitudinal welds. The base shall attach to the shaft with a 100 percent penetration circumferential welds. The base shall taper to a round bottom allowing ample room to house the winch and totally conceal the required number of anchor bolts. The integral base plate shall be attached to the skirt by means of two circumferential fillet welds. A reinforced access opening of ample size to allow for servicing and maintenance shall be provided with the skirt. A flush mounted door cover shall be secured with a minimum of four screws.
- e. The pole top shall be fitted with a channel or flange for mounting the head assembly to the lowering system. Pole and lowering system shall be compatible.
- f. The pole, complete with lowering device and luminaires in place, shall be capable of withstanding a sustained wind velocity of not less than 100 mph, with gust wind velocity of 1.3 times the sustained wind velocity. The wind velocity and pole stresses shall be calculated in accordance with AASHTO 1975 Standard specifications.
- g. The pole shaft and base shall be cleared of grease, dirt, and weld splatter and galvanized in accordance with ASTM A 123.
- h. Provide air terminal at top of pole as required for lightning protection system.
- i. Provide FAA approved medium dual obstruction light beacon at the top of each pole indicated, per FAA AC 70/7460-1K, "Obstruction

REPAIR AIRFIELD RAMP LIGHTS

Marking and Lighting", Chapters 4, 8, and 12. Obstruction light shall include a steady burning red light for nighttime use, a flashing white light for daytime use and the sensor and controls required to operate the beacon. The flashing strobe shall be synchronized so as to flash simultaneously with all other obstruction lights installed under this contract.

- j. Grounding and Bonding Lugs: Welded 1/2 inch threaded lug, complying with requirements in Section 33 71 02.00 10 "Electrical Distribution System, Underground", listed for attaching grounding and bonding conductors of type and size listed in that Section, and accessible through handhole.

2.5.1.2 Lowering Device

- a. Arrange system to lower luminaire assembly to a servicing position within 3 feet of finished grade in winds up to 20 miles per hour and to provide for manual plug connection to electrical power in the lowered position for testing.
- b. The lowering device shall be a cable hoisting system consisting of a galvanized steel head assembly, galvanized steel luminaire ring and junction box, galvanized steel winch drums and corrosive resistant winching system, and a portable power unit.
- c. The head assembly shall be manufactured of galvanized steel and shall consist of formed channel(s) bolted to the top of the pole shaft with four galvanized steel bolts, nuts, and lockwashers. The channel(s) shall support a minimum of four cable sheaves 6 inch in diameter, shall be provided with a special cable keeper to assure proper cable guidance, and two pilot guides to secure the horizontal position of the luminaire ring. The power cable sheaves shall be made of cast aluminum a minimum of 16 inch in diameter. All sheaves shall have permanently lubricated bronze bearings and stainless steel axle pins. A cable keeper shall be provided to prevent the power cable from working out of the sheave.
- d. Luminaire ring assembly:
 - 1. The luminaire ring assembly shall be fabricated of galvanized steel and consist of the luminaire ring, hoisting cable terminator tubes, and weatherproof junction box(es), all of galvanized steel. The inner portion of the ring shall be equipped with a PVC shock absorbing tube protecting the pole and the luminaires during the raising and lowering operation. The ring shall be supplied with galvanized steel mounting brackets for the luminaire mounting frame assembly. The power cord(s) shall be terminated into the luminaire ring by a deluxe Kellems type grip. The luminaire ring shall be a totally enclosed wireway. The ring shall be raised, supported, and lowered by two 1/4 inch stainless steel 7 by 19 strand cables, each with a hoisting strength of 6000 pounds.
 - 2. The hoisting cables shall be continuous from the luminaire ring to the winch drum and of sufficient length to be 2 times the length of the pole shaft plus 20 feet.
 - 3. The luminaire assembly shall be held firm to the masthead assembly by two compression springs or latching barrels at the end of the hoisting cables and within the stainless steel support

REPAIR AIRFIELD RAMP LIGHTS

cable terminal tubes. The springs or barrels shall hold the weight of the luminaire ring assembly and the luminaire plus 300 pounds, and shall support the luminaire ring and unload the hoisting cables and winch when not in operation of lowering or raising the ring assembly.

4. The power cord shall be type W, with four conductors plus ground, size as indicated, and provided with a 30 A, 600 V twist lock weatherproof male connection. The power cable shall be tethered between the hoisting cables with a galvanized steel harness.

5. Two galvanized steel chains and grippers shall secure the hoisting cables to the base of the pole while in the static load position. The ultimate support of the luminaire ring shall not be dependent upon the winch assembly, nor shall there be latches at the top of the pole or in the masthead assembly.

6. Ultimate support of the luminaire ring shall not be sacrificed by individual or total spring or barrel failure.

2.5.1.3 Winch and Power Unit

- a. The portable winch/motor assembly shall have an ultimate strength of five times the lifted load. The winch assembly shall consist of a gear speed reducer. The gear housing shall be cast aluminum or other non-corrosive material. The assembly shall also consist of an output shaft and a steel drum supported at both ends and a stainless steel cable keeper designed to aid the correct spooling of the winch cable. The input or drive pulley shall be equipped with a safety brake when either the motor drive belt or the motor is removed. Raising speed of the luminaire ring shall be a minimum of 10 feet per minute.
- b. The portable motor power unit shall consist of a TEFC NEMA 56 C face motor, reversible with brake attached. The power unit shall be mounted to the winch with an integral bracket and a V-drive belt. The motor shall be equipped with a power cord and a weatherproof connector to mate with the power supply cord connector. The motor shall be operated by a push button or drum switch control on a 20 foot long cord.
- c. Motor assembly shall include a step down transformer from 480 volts to motor supply voltage and mounted on a two wheel cart.
- d. Provide one winch and power unit.

2.6 POLE FOUNDATIONS

Anchor bolts shall be steel rod having a minimum yield strength of 50,000 psi; the top 12 inches of the rod shall be galvanized in accordance with ASTM A 153/A 153M. Concrete shall be as specified in Section 03 30 53 MISCELLANEOUS CAST-IN-PLACE CONCRETE.

2.7 EQUIPMENT IDENTIFICATION

2.7.1 Manufacturer's Nameplate

Each item of equipment shall have a nameplate bearing the manufacturer's

REPAIR AIRFIELD RAMP LIGHTS

name, address, model number, and serial number securely affixed in a conspicuous place; the nameplate of the distributing agent will not be acceptable.

2.7.2 Labels

Provide labeled luminaires in accordance with UL 1598 requirements. Luminaires shall be clearly marked for operation of specific lamps and ballasts according to proper lamp type. The following lamp characteristics shall be noted in the format "Use Only _____":

- a. Lamp type, wattage, bulb type (ED17, BD56, etc.) and coating (clear or coated) for HID luminaires.
- b. ANSI ballast type (M98, M57, etc.) for HID luminaires.
- c. Correlated color temperature (CCT) and color rendering index (CRI) for all luminaires.

Markings related to lamp type shall be clear and located to be readily visible to service personnel, but unseen from normal viewing angles when lamps are in place. Ballasts shall have clear markings indicating multi-level outputs and indicate proper terminals for the various outputs.

2.8 FACTORY APPLIED FINISH

Electrical equipment shall have factory-applied painting systems which shall, as a minimum, meet the requirements of NEMA 250 corrosion-resistance test.

PART 3 EXECUTION

3.1 INSTALLATION

Electrical installations shall conform to IEEE C2, NFPA 70, and to the requirements specified herein.

3.1.1 Steel Poles

Provide pole foundations with galvanized steel anchor bolts, threaded at the top end and bent 90 degrees at the bottom end. Provide galvanized nuts and washers for anchor bolts. Concrete for anchor bases shall be as specified in Section 03 30 53 MISCELLANEOUS CAST-IN-PLACE CONCRETE. Polyvinyl chloride (PVC) conduit ells and ground rods shall be as specified in Section 33 70 02.00 10 ELECTRICAL DISTRIBUTION SYSTEM, UNDERGROUND. Thoroughly compact backfill with compacting arranged to prevent pressure between conductor, jacket, or sheath and the end of conduit ell. Adjust poles as necessary to provide a permanent vertical position with the Luminaire Mounting Frame in proper position for luminaire location.

3.1.2 Photocell Switch Aiming

Aim switch according to manufacturer's recommendations. Set adjustable window slide for 3 footcandles photocell turn-on.

3.1.3 GROUNDING

Ground noncurrent-carrying parts of equipment including metal poles, luminaires, mounting arms, brackets, and metallic enclosures as specified

REPAIR AIRFIELD RAMP LIGHTS

in Section 33 70 02.00 10 ELECTRICAL DISTRIBUTION SYSTEM, UNDERGROUND.
Where copper grounding conductor is connected to a metal other than copper,
provide specially treated or lined connectors suitable for this purpose.

3.1.4 FIELD APPLIED PAINTING

Paint electrical equipment as required to match finish of adjacent surfaces
or to meet the indicated or specified safety criteria.

3.2 FIELD QUALITY CONTROL

Upon completion of installation, verify that equipment is properly
installed, connected, and adjusted. Conduct an operating test to show that
the equipment operates in accordance with the requirements of this section.

-- End of Section --

BLANK PAGE

LANGLEY AIR FORCE BASE TELECOMMUNICATIONS BUILDING CABLING SYSTEMS STANDARDS 27 10 10

2 June 2008

This standard supersedes Langley AFB Premise Wiring Distribution Systems Standard dated prior to 2 June 2008. This standard also supersedes Contract Specifications Section 16710 and Section 27 10 00 dated prior to 2 June 2008.

FOREWORD The Langley Air Force Base (LAFB) Telecommunications Building Cabling System (TBCS) Standard applies to the Military Construction Projects, Civil Engineering Renovation Building Projects, in accordance with Engineering Technical Letter (ETL) 02-12, Unified Facilities Criteria (UFC) 3-580-01, and technical references provided in this standard. The LAFB TBCS Standard will be used for Military Construction and renovation projects and work for other customers where appropriate. Recommended changes with supporting rationale should be sent to 1 CS/SCX for consideration.

The intent of this standard is to:

- (1). Ensure the system is complete and ready for customer occupancy.
- (2). Prevent facility defacement that would occur if communications infrastructure were not integrated into the facility design and acquisition process.
- (3). Comply with technical architectures and basic standards to ensure compatibility, flexibility, and long-term customer support.
- (4). Provide standardization thereby reducing the need and cost of future modifications that would result from changes in facility occupancy or user reorganization.
- (5). Eliminate funding disconnects that result from fragmenting appropriations sources for communications infrastructure acquisition.
- (6). Realize beneficial effects of enhanced maintenance effort and training qualification by providing standardized communications throughout Langley AFB.

DISTRIBUTION:

1st Communications Squadron
1st Contracting Squadron
1st Civil Engineering Squadron
U.S. Army Corps of Engineer

TABLE OF CONTENTS

PART 1. GENERAL	1
1.1 REFERENCES	1
1.2. ACRONYMS AND ABBREVIATIONS	2
1.3. SYSTEM DESCRIPTION	3
1.4. QUALIFICATIONS	4
1.4.1. Telecommunications Qualification	4
1.4.2. Minimum Manufacturer Qualifications	4
1.5. SUBMITTALS	4
1.5.1.1. Product Data	5
1.5.1.2. Standard Products	5
1.5.1.3. Spare Parts	5
1.5.2.1. Premises Distribution System Shop Drawings	5
1.5.2.2. Telecommunications Drawings	6
1.5.3. Instructions	7
1.5.4. Statements	7
1.5.4.1. Test Plan	7
1.5.5. Reports	7
1.5.6. Certificates	7
1.6. DELIVERY AND STORAGE	7
1.7. OPERATION AND MAINTENANCE MANUALS	8
1.8. RECORD KEEPING AND DOCUMENTATION	8
PART 2 PRODUCTS	8
2.1. MATERIALS AND EQUIPMENT	8
2.2. UNSHIELDED TWISTED PAIR CABLE SYSTEM	8
2.2.5. Cable Insulation	8
2.2.6.1. Riser/Backbone Cable	8
2.2.6.2. Horizontal Cable	9
2.2.7. Connecting Hardware	9
2.2.7.4. Telecommunications Outlets	9
2.2.7.5. Unshielded Twisted Pair Patch Panels	10
2.2.7.6. Terminal Blocks	10
2.2.8. Patch Cables	11
2.3. FIBER OPTIC CABLE (FOC) SYSTEM	11
2.3.1. Fiber Optic Cabling	11
2.3.2. Connecting Hardware	11
2.3.2.4. Innerduct	12
2.3.2.5. Fiber Optic (FO) Patch Cables	12
2.4. EQUIPMENT RACKS	12
2.4.1. Floor Mounted Open Frame	13
2.4.2. Wall Mounted Swing Cabinet	13

2.4.3. Cable Management	13
2.5. EQUIPMENT MOUNTING BACKBOARD	13
TABLE OF CONTENTS (CONT.)	
2.6. TELECOMMUNICATIONS OUTLET BOXES	14
2.7. TELECOMMUNICATIONS ROOM REQUIREMENTS	14
2.8. Miscellaneous Products	15
2.8.1. Surface Mounted Non Metallic Raceway	15
2.8.2. Tele/Power (Utility) Pole	15
2.8.3. Firestop	16
PART 3 EXECUTION	16
3.1. INSTALLATION	16
3.1.1. Horizontal Distribution Cable	16
3.1.2. Riser Backbone Cable	17
3.1.3. Telecommunication Outlets	17
3.1.4. Terminal Blocks	18
3.1.5. Patch Panels	19
3.1.6. Telecommunications Equipment Racks	19
3.1.7. Telecommunications Equipment Cabinets	19
3.1.8. Rack Mounted Equipment	20
3.1.9.1. Ladder and Wire Cable Tray	20
3.1.9.2. Conduit	20
3.1.9.3. Pull Boxes	21
3.1.9.4. Raceway	21
3.2. TERMINATIONS	21
3.2.1. Unshielded Twisted Pair Cable	21
3.2.2. Fiber Optic Cable (FOC)	21
3.2.3.1. Systems Furniture Wiring	21
3.2.3.3. Communications (Utility) Pole	22
3.2.3.4. Multi-User Telecommunication Outlet Assembly (MUTOA)	22
3.2.3.5. Consolidation Point (CP)	22
3.2.3.6. Utility Rooms and Closets	23
3.2.3.7. Elevators	23
3.2.3.8. Safety, Courtesy, & Convenience	23
3.2.3.9. Building Automation Systems	23
3.3. BONDING AND GROUNDING	23
3.4. ADDITIONAL MATERIALS	24
3.5. ADMINISTRATION AND LABELING	24
3.6. COMMUNICATION CABLING INSPECTION AND TESTING	25
3.6.1. Inspection	25
3.6.2. CABLE TESTING	26
3.7. ACCEPTABILITY	27
3.8. TEST REPORTS	27
FIGURES	28

PART 1. GENERAL

1.1 REFERENCES

The most current issue of the publications listed below form a part of this specification to the extent referenced. The publications are referred to in the text by basic designation only.

TELECOMMUNICATIONS INDUSTRIES ASSOCIATION (TIA)

Telecommunications Industry Association (TIA)
2500 Wilson Blvd., Suite 300 Arlington, VA 22201
ph: (703) 907-7700 fx: (703) 907-7727
<http://www.tiaonline.org/>

TIA-526-7	Measurement of Optical Power Loss of Installed Single-Mode Fiber Cable Plant – OFSTP-7
TIA-526-14-A	Optical Power Loss Measurements of Installed Multimode Fiber Cable Plant – OFSTP-14
TIA/EIA-568-B.1	Commercial Building Telecommunications Cabling Standard Part 1: General Requirements
TIA/EIA-568-B.2	Commercial Building Telecommunications Cabling Standard Part 2: Balanced Twisted-Pair Cabling Components
TIA/EIA-568-B.3	Optical Fiber Cabling Components Standard
TIA-569-B	Commercial Building Standard for Telecommunications Pathways and Spaces
TIA-570-B	Residential Telecommunications Infrastructure Standard
TIA-598-C	Optical Fiber Cable Color Coding
TIA/EIA-606	Administration Standard for Commercial Telecommunications Infrastructure
J-STD-607-A	Commercial Building Grounding (Earthing) and Bonding Requirements for Telecommunications
TIA-758-A	Customer-owned Outside Plant Telecommunications Infrastructure Standard
EIA-TSB 67	Transmission Performance Specifications for Field Testing of Unshielded Twisted Pair Cabling Systems
EIA-TSB-75	Additional Horizontal Cabling Practices for Open Offices

INSULATED CABLE ENGINEERS ASSOCIATION (ICEA)

IHS
15 Inverness Way East, Englewood, CO 80112
ph:(800) 854-7179, fax: (303) 397-2740
Email: global@ihs.com
Website: <http://store.ihs.com>

ICEA S-80-576	Communications Wire and Cable for Wiring of Premises
---------------	--

NATIONAL FIRE PROTECTION ASSOCIATION (NFPA)

NFPA (National Fire Protection Association),
1 Batterymarch Park Quincy, MA 02269-9101
ph: (617) 770-3000 fax: (617) 770-0700
www.nfpa.org

NFPA 70	National Electrical Code
NFPA 780	Standard for the Installation of Lightning Protection Systems

MILITARY STANDARD (MIL-STD)

MIL-STD-188-124B Grounding, Bonding and Shielding

1.2. ACRONYMS AND ABBREVIATIONS

ADA	Americans with Disabilities Act
ADN	Area Distribution Node
AFF	Above Finished Floor
AMEP	Architectural, Mechanical, Electrical, and Plumbing
AMP	Ampere
ANSI	American National Standards Institute
AWG	American Wire Gauge
BCES	Base Civil Engineering Squadron
BCSO	Base Communications Systems Officer
BICSI	Building Industry Consulting Service, International, Inc.
BTCS	Building Telecommunications Cabling Systems
CAT	Category
CD-ROM	Compact Disc - Read Only Memory
cm	centimeters
CMP	Communications Plenum Cable
CO	Contracting Officer (USAF)
CS	Communications Squadron
CP	Consolidation Point
dB	Decibel
dB/KM	Decibels per Kilometer
DC	Direct Current
DDC	Direct Digital Controller
EES	Earth Electrode Subsystem
EIA	Electronics Industry Alliance
ELFEXT	Equal Level Far End Crosstalk
EMCS	Emergency Monitoring and Control System
EMT	Electrical Metallic Tubing
F	Fahrenheit
FO	Fiber Optic
FOC	Fiber Optic Cable
ft	Foot or Feet
GE	Grounding Equalizer
HVAC	Heating, Ventilation and Air Conditioning
ICEA	Insulated Cable Engineering Association
IDC	Insulation Displacement Connector
IDF	Intermediate Distribution Frame
ID	Identification
in	Inches

1.2. ACRONYMS AND ABBREVIATIONS (cont.)

LAFB	Langley Air Force Base
LAN	Local Area Network
lb/f	pounds per foot
lx	lux
m	Meter
MDF	Main Distribution Frame
MHz	Megahertz
MILCON	Military Construction
mm	millimeter
MUTOA	Multi-User Telecommunication Outlet Assembly
NEC	National Electrical Code
NESC	National Electrical Safety Code
NEXT	Near End Cross Talk
NFPA	National Fire Protection Association, Inc.
O&M	Operations and Maintenance
OEM	Original Equipment Manufacturer
OSP	Outside Plant
PM	Project Manager
PSELFEXT	Power Sum Equal Far End Cross Talk
PSNEXT	Power Sum Near End Cross Talk
RCDD	Registered Communications Distribution Designer
RUS	Rural Utilities Service
SC	Subscriber Connector (Fiber Optic Connector)
SME	Subject Matter Expert (USAF)
ST	Straight Tip (Fiber Optic Connector)
TBB	Telecommunications Bonding Backbone
TEF	Telecommunications Entrance Facility
TGB	Telecommunications Grounding Busbar
TIA	Telecommunications Industry Association
TMGB	Telecommunications Main Grounding Busbar
TR	Telecommunications Room
UL	Underwriters Laboratory, Inc.
USACE	United States Army Corps of Engineers
UTP	Unshielded Twisted Pair
VAC	Volts Alternating Current

1.3. **SYSTEM DESCRIPTION** The premises wiring distribution system shall consist of permanently installed backbone and horizontal cabling, horizontal and backbone pathways, service entrance facilities, and work area pathways, telecommunications outlet assemblies, conduit, raceway, and hardware for terminating and interconnecting to transport telecommunications (eg. telephone) and data (eg. Local Area Network) signals between equipment items in a building. The premises wiring distribution system shall be provided as a complete system, to include complete telecommunication room (TR) with

dedicated climate control and full wire pathway support from entry into TR and wire management system on equipment racks/cabinets. This will also include complete telecommunications grounding/bonding backbone system. The entire premises wiring distribution system shall be provided in accordance with above listed references and specifications outlined in this standard.

1.3.1. (Reserved)

1.3.2. **RELATED REQUIREMENTS - LIST OTHER SECTIONS THAT APPLY TO THIS SECTION WITH ADDITIONS AND MODIFICATIONS SPECIFIED HEREIN.**

1.3.3. Insulated Cable Engineers Association (ICEA) and American National Standards Institute (ANSI) specifications are listed in the references, and can be purchased at <http://global.ihs.com>.

1.4. QUALIFICATIONS

1.4.1. **Telecommunications Qualification** All work under this section shall be performed by and all equipment shall be furnished and installed by a certified Telecommunications Contractor, hereafter referred to as the Contractor. The Contractor shall have the following qualifications in the Telecommunications Systems installation. Qualifications shall be provided for: the telecommunications system contractor, the telecommunications system installer, and the supervisor (if different from the installer). A minimum of 30 days prior to installation, submit documentation of the experience of the telecommunications contractor and of the key personnel.

1.4.1.1. The Contractor shall be a firm which is regularly and professionally engaged in the business of the application, installation, and testing of the specified telecommunications systems and equipment. The telecommunications contractor shall demonstrate experience in providing successful telecommunications systems of like magnitude within the past three years. Submit documentation for a minimum of three and a maximum of five successful telecommunications system installations for the telecommunications contractor.

1.4.1.2. The Contractor shall have all design proposals, shop drawings, and installation plans prepared by a Registered Communications Distribution Designer (RCDD) and certified as compliant with Building Industry Consulting Services International (BICSI) design practices, American National Standards Institute (ANSI), Telecommunications Industry Association (TIA) standards, and the specifications outlined in this standard by.

1.4.1.3. All supervisors and installers shall have factory certification from each equipment manufacturer that they are qualified to install and test the provided products. General electrical trade staff (electricians) shall not be used for the installation of the premise wiring distribution system cables and associated hardware unless.

1.4.1.3.1. All supervisors assigned to the installation of this system or any of its components shall have a minimum Level 2 Installer certification from BICSI with a minimum of five (5) years experience in systems of same size and complexity.

1.4.1.3.2. All installers assigned to the installation of this system or any of its components shall have a minimum Level 1 Installer certification from BICSI with a minimum of three (3) years experience in the installation of the specified copper and fiber optic cable (FOC) and their components.

1.4.2. **Minimum Manufacturer Qualifications** The equipment and hardware provided under this contract shall be from manufacturers that have a minimum of three (3) years experience in producing the types of systems and equipment specified.

1.5. **SUBMITTALS** Government approval is required for submittals. The following shall be submitted to the Contracting Officer (USAF) for review and approval by the Base Communications Systems Officer (BCSO). Any and all equipment ordered by the Contractor without the explicitly written approval from the Government is at the Contractor's own risk of compliance with the requirements of this project.

1.5.1. **Data**

1.5.1.1. **Product Data** Provide complete product data on all system equipment, components and cabling, racks/cabinets, patch panels, telecommunications outlets/connector assemblies, outlet boxes, conduit, cable tray, cable supports, equipment support frame, cable management, cross connects, grounding, fiber optic patch panels, etc.

1.5.1.1.1. Submittals shall include the manufacturer's name, trade name, place of manufacture, and catalog model or number. Include performance and characteristic curves.

1.5.1.1.2. Submittals shall also include applicable federal, military, industry, and technical society publication references. Should manufacturer's data require supplemental information for clarification, the supplemental information shall be submitted to the CO for concurrence by the BCSO.

1.5.1.2. **Standard Products** Provide materials and equipment that are products of manufacturers regularly engaged in the production of such products which are of equal material, design and workmanship. Products shall have been in satisfactory commercial or industry use for two years prior to bid opening. The two-year period shall include applications of equipment and materials under similar circumstances and of similar size. The product shall have been on sale on the commercial market through advertisements, manufacturers' catalogs, or brochures during the two-year period. Where two or more items of the same class of equipment are required, these items shall be products of a single manufacturer; however, the component parts of the item need not be the products of the same manufacturer unless specifically identified by the CO.

1.5.1.2.1. **Alternative Qualifications** Products having less than a two-year field service record will be acceptable if a certified record of satisfactory field operation for not less than 6000 hours, exclusive of the manufacturers' factory or laboratory tests, is furnished.

1.5.1.2.2. **Material and Equipment Manufacturing Date** Products manufactured more than three years prior to date of delivery to site shall not be used, unless specified otherwise.

1.5.1.3. **Spare Parts** Spare parts, tools, and test equipment provided under this contract, along with an inventory of these spare parts, tools, and test equipment, shall be submitted to CO for review and approval by the BCSO. The inventory data shall include a complete list of parts and supplies, with current unit prices and source of supply, and a list of spare parts recommended for stocking.

1.5.2. **Drawings**

1.5.2.1. **Premises Distribution System Shop Drawings** Shop (Installation) Drawings shall be provided for the installed wiring system infrastructure per EIA ANSI/TIA/EIA-606. Submit Shop Drawings a minimum of ANSI D (17-in. x 22-in.) drawing format using a minimum scale of 1/8 inch per foot. Shop drawings shall graphically document the telecommunications infrastructure to be installed. They shall illustrate relevant infrastructure elements and describe the means of installation. Detail drawings shall contain complete wiring and schematic diagrams and other details required to demonstrate that the system has been coordinated and will function properly as a system.

1.5.2.1.1. Drawings shall include vertical riser diagrams, equipment rack details (to include complete wire management support systems in the TRs), elevation drawings of TR wall, outlet face plate details for all outlet configurations, size and types of cables, conduits, and cable trays.

1.5.2.1.2. Drawings shall show proposed layout and anchorage of equipment and appurtenances and equipment relationship to other parts of the work including clearance for maintenance and operation.

1.5.2.1.3. The drawings shall show the location of all cable terminations and location and routing of all backbone cables, vertical riser cables, horizontal cables, elevation drawings of TR wall, outlet face plate details for all outlet configurations, size and types of cables, conduits, and cable trays.

1.5.2.1.4. Drawings shall indicate equipment rack details (to include complete wire management support systems and equipment elevation), proposed layout and anchorage of equipment.

1.5.2.1.5. Drawings shall indicate adequate clearance for operation, maintenance, and replacement of operating equipment devices.

1.5.2.1.6. Drawings shall show details of other items that must be shown to ensure a coordinated installation. Submittals shall also include applicable federal, military, industry, and technical society publication references.

1.5.2.1.7. The Telecommunications Contractor will receive design approval from the CO with concurrence from the BCSO prior to installation.

1.5.2.2. **Telecommunications Drawings** Provide Registered Communications Distribution Designer (RCDD) approved, Telecommunications Drawings in accordance with EIA ANSI/TIA/EIA-606. Detail drawings, size ANSI E (34-in. x 44-in.) drawing format, shall include the identifier for each termination and cable shall appear on the drawings. Drawings shall depict final telecommunications installed wiring system infrastructure. The drawings shall provide details required to prove that the telecommunications infrastructure system shall properly support connectivity from the telecommunications entrance facility and telecommunications equipment room, through the distribution system(s), to the telecommunications work area outlets.

1.5.2.2.1. The Contractor shall provide two copies of completed as-built drawings in hardcopy format and one electronic copy on CD-ROM in Autocad format prior to final acceptance.

1.5.2.2.2. Provide a plastic laminated schematic of the as-installed telecommunications cable system showing cabling, distribution system(s), and telecommunications spaces keyed to floor plans by room number. Mount the laminated schematic in each TR as directed by the Contracting Officer (CO).

1.5.2.2.3. The following drawings shall be provided as required:

1.5.2.2.3.1. **T0 – Campus or Site Plans** - Exterior Pathways and Campus Backbones Shows physical and logical connections from the perspective of an entire campus, such as actual building locations, exterior pathways and campus backbone cabling on plan view drawings, major system nodes, and related connections on the logical system drawings.

1.5.2.2.3.2. **T1 – Layout of complete building per floor** - Building Area/Serving Zone Boundaries, Backbone Systems, and Horizontal Pathways Layout of complete building per floor. The drawing indicates location of building areas, serving zones, vertical backbone diagrams, TRs, access points, pathways, grounding system, and other systems that need to be viewed from the complete building perspective.

1.5.2.2.3.3. **T2 - Serving Zones/Building Area Drawings** - Drop Locations and Cable Identification (ID) shows a building area or serving zone. These drawings show drop locations, TRs, access points and detail call outs for common equipment rooms and other congested areas.

1.5.2.2.3.4. **T3 – Telecommunications Rooms (TRs)** - Plan Views - Tech and architectural, mechanical, electrical, and plumbing (AMEP) /Elevations - Racks and Walls Elevations Detailed look at TR. Drawing

indicates technology layout (racks, ladder-racks, etc.), mechanical/electrical layout, rack elevation and backboard elevation. May also be an enlargement of a congested area of a T1 or T2 drawing.

1.5.2.2.3.5. **T4 – Typical Detail Drawings** - Faceplate Labeling, Firestopping, Americans with Disabilities Act (ADA), Safety, etc. Detailed drawings of symbols and typicals such as faceplate labeling, faceplate types, installation procedures, detail racking, and raceways.

1.5.2.2.3.6. **T5 – Schedules** (spreadsheets) to show information for cut-overs and cable plant management.

1.5.3. Instructions

1.5.3.1. **Manufacturer's Recommendations** Where installation procedures, or any part thereof, are required to be in accordance with the recommendations of the manufacturer of the material being installed, printed copies of these recommendations, prior to installation shall be provided. Installation of the item will not be allowed to proceed until the recommendations are received and approved.

1.5.4. Statements

1.5.4.1. **Test Plan** Provide a complete and detailed test plan for the telecommunications cabling system(s) including a complete list of test equipment for the UTP components and accessories submitted 60 days prior to the proposed test date. The test plans shall define the tests required to ensure that the system meets technical, operational and performance specifications. The test plan must be approved before the start of any testing. The test plan shall identify the capabilities and functions to be tested, and include detailed instructions for the setup and execution of each test and procedures for evaluation and documentation of the results.

1.5.4.2. **Qualifications** The qualifications of the Manufacturer, Contractor, and the Installer to perform the work specified herein shall be provided. This shall include proof of the minimum qualifications specified herein.

1.5.5. Reports

1.5.5.1. **Test Reports** Test reports shall be provided in booklet form with witness signatures verifying execution of tests. Reports shall show the field tests performed to verify compliance with the specified performance criteria. Test reports shall include record of the physical parameters verified during testing. Test reports shall be submitted within 7 days after completion of testing and prior to final acceptance of the project to the CO for review and approval by the BCSO for Quality Assurance Inspection purposes.

1.5.6. Certificates

1.5.6.1. **Premises Distribution System** The Contractor shall have all design proposals, shop drawings, and installation plans certified as compliant with Building Industry Consulting Services International (BICSI) design practices, American National Standards Institute (ANSI), Telecommunications Industry Association (TIA) standards, and the specifications outlined in this standard by a Registered Communications Distribution Designer (RCDD).

1.5.6.2. **Materials and Equipment** Where materials and equipment are specified to conform, be constructed, or tested to meet specific requirements, certification that the items conform to such requirements must be provided. Certification by a nationally recognized testing laboratory that a representative sample has been tested to meet the requirements, or a published catalog specification statement to the effect that the item meets the referenced standard, will be acceptable as evidence that the item conforms. Compliance with these requirements does not relieve the Contractor from compliance with other requirements of the specification.

1.5.6.3. **Installers** The Contractor shall submit certification to the CO, for review and approval by the BCSO, that all the installers are factory certified to install and test the provided products.

1.6. **DELIVERY AND STORAGE** Equipment delivered and placed in storage shall be stored with protection from the weather, humidity and temperature variation, dirt and dust, or other contamination.

1.7. **OPERATION AND MAINTENANCE MANUALS** Commercial off the shelf manuals shall be furnished for operation, installation, configuration, and maintenance for all products provided as a part of the premises distribution system. Specification sheets for all cable, connectors, and other equipment shall be provided.

1.8. RECORD KEEPING AND DOCUMENTATION

1.8.1 **Cables** The Contractor shall be responsible for recording and providing, to the CO, all test data within 7 days of system final testing. A record of all installed cable shall be provided in hard copy format per ANSI TIA/EIA-606. The cable records shall include the required data fields for each cable and complete end-to-end circuit report for each complete circuit from the assigned outlet to the entry facility per ANSI TIA/EIA-606. For all FOC, power meter test results shall be provided in a hard copy format. All twisted pair copper cables shall have a disk copy output of the test results with station ID assigned.

1.8.2. **Termination Hardware** A record of all installed patch panels and outlets shall be provided in hard copy format per ANSI TIA/EIA-606. The hardware records shall include only the required data fields per ANSI TIA/EIA-606.

PART 2 PRODUCTS

2.1. **MATERIALS AND EQUIPMENT** Materials and equipment shall be the standard products of a manufacturer regularly engaged in the manufacture of the products and shall be the manufacturer's latest standard design that has been in satisfactory use for at least 1 year prior to installation. Materials and equipment shall conform to the respective publications and other requirements specified below and to the applicable requirements of NFPA 70.

2.2. UNSHIELDED TWISTED PAIR CABLE SYSTEM

2.2.1. Use only cable that has passed the Underwriters Laboratory (UL) LAN certification program and is labeled with UL acceptable markings indicating performance level of cable.

2.2.2. Conductors shall be solid untinned copper 24 AWG.

2.2.3. Cable shall be rated Plenum (CMP) per NFPA 70.

2.2.4. Cable shall be label-verified.

2.2.5. Cable Insulation

2.2.5.1. For each individual horizontal cable, the insulation, material used on each pair shall be exactly the same in all physical, electrical, and chemical respects.

2.2.5.2. The use of plenum rated cable is required for both plenum and non-plenum environments.

2.2.5.3. Plenum rated cable shall be type 4x0, where all four pairs are insulated. Type 3x1 and 2x2 are not acceptable.

2.2.6. Unshielded Twisted Pair Cables

2.2.6.1. Riser/Backbone Cable Multi-pair voice backbone cable must meet the requirements of Insulated Cable Engineers Association (ICEA) S-80-576 and TIA/EIA-568-B.2 for riser rated unshielded twisted pair cable.

2.2.6.2. Horizontal Cable

2.2.6.2.1. Horizontal cable shall meet the requirements of EIA ANSI/TIA/EIA-568-b.1 for horizontal cable. The category for cable, jacks, termination blocks, and patch panels must be the same throughout each circuit and system.

2.2.6.2.2. Horizontal cable shall be Category 5e or better unshielded twisted pair (UTP) cable must be installed to each standard 8-pin modular connector provisioned at the outlet.

2.2.6.2.3. All horizontal cables to be installed on any particular installation will be from the same manufacturer.

2.2.6.2.4. Cable color will be the same throughout the particular facility. The only exception to this will be, if multiple comm. closets are to be installed in a particular facility, these closet distribution cables may be separate colors to differentiate the difference of comm. closet distribution. Recommended colors for distribution cables are white, gray, or blue.

2.2.7. Connecting Hardware

2.2.7.1. Hardware shall be in accordance with and EIA ANSI/TIA/EIA-568-b.2.

2.2.7.2. Connecting and cross-connecting hardware shall be the same category rating as the cable it serves.

2.2.7.3. Connecting and cross-connecting hardware shall be typically provided as type 110 insulation displacement connection termination unless alternative is specified by the BCSO. In some cases, 66-Block style of terminating blocks may be required.

2.2.7.4. Telecommunications Outlets

2.2.7.4.1. Outlet Faceplate

2.2.7.4.1.1. Outlet Faceplates shall be a 4 or 6 port single gang faceplate with screw cover, labels, and a curved, designer appearance. Each faceplate accepts individual connector modules for all copper and (if used) FOC.

2.2.7.4.1.2. Standard administrative outlets may, by specific user request, use single gang outlet faceplates in conjunction with a reducing ring. For single gang outlet boxes, use a single gang outlet faceplate with appropriate connector locations and, if required, mounting lugs for wall phones.

2.2.7.4.1.3. Outlet Faceplates shall provide a system for attaching and protecting outlet labels. Adhesive labeled are not to be used on outlet faceplates. Outlets shall be labeled according to the LAFB standard labeling scheme (reference figure 1).

2.2.7.4.1.4. Outlet Faceplates shall be provided and coincide with the surrounding decor.

2.2.7.4.2. Copper Outlet/Connector

2.2.7.4.2.1. All outlets shall utilize interchangeable connector modules that mount side by side to facilitate moves, adds and changes. Connector modules shall be available to support high performance copper and fiber cabling systems. All outlets shall be manufactured from high impact thermoplastic material with an U.L. flammability rating of 94HB or better.

2.2.7.4.2.2. All connectors must be 8-pin/8-position insulation displacement terminations wired per T568A in accordance with EIA ANSI/TIA/EIA-568-b.1. Category 3 (Cat 3) rated connectors shall not be used.

2.2.7.4.2.3. Outlet/connector and plugs shall be the same category as the cable they terminate and shall meet the requirements of EIA ANSI/TIA/EIA-568-b.2.

2.2.7.4.2.4. Outlet termination shall be type 110 insulation displacement connection.

2.2.7.4.2.5. Outlet/connector and plugs shall be unkeyed.

2.2.7.4.3. Outlet Types

2.2.7.4.3.1. Outlet configurations must comply with this standard, TIA/EIA-568-B, and TIA/EIA-569-B.

2.2.7.4.3.2. Outlet assemblies used for administrative facilities and administrative spaces shall consist of modular jacks assembled in a quadra-plex outlet configuration in single gang covers.

2.2.7.4.3.3. The quadra-plex outlet type does not cover all possible user required configurations. Each outlet type shall be depicted and referenced on the shop drawings (reference Fig. 6 for sketches of commonly used outlet types).

2.2.7.4.4. Standard of quality for Telecommunications Outlets shall be Hellermann Tyton or equivalent.

2.2.7.5. Unshielded Twisted Pair Patch Panels

2.2.7.5.1. Patch panels shall be category rated for the UTP system being installed, and arranged in rows or columns on 19-in (475 mm) rack mounted panels.

2.2.7.5.2. Provide a maximum panel size of 48 jacks (preferably with jacks grouped in fours if available).

2.2.7.5.3. Patch Panels shall consist of eight-position, unkeyed modular jacks, with rear mounted type 110 insulation displacement connectors (IDC).

2.2.7.5.4. Jack pin/pair configuration shall be T568A per ANSI/TIA/EIA-568-b1.

2.2.7.5.5. Copper cables must not be split between multiple modular connectors.

2.2.7.5.6. Provide a minimum spare capacity of 10%.

2.2.7.5.7. Panels shall be labeled in accordance with LAFB standard labeling scheme, matched to the corresponding work area outlet.

2.2.7.6. Terminal Blocks

2.2.7.6.1. Terminal blocks shall be category rated for the UTP system being installed and typically used to terminate backbone cables to equipment racks/cabinets.

2.2.7.6.2. Insulation displacement connectors (IDC) shall terminate 24 AWG solid copper wire as a minimum.

2.2.7.6.3. Terminal Blocks shall be connected in sequential pairs so that horizontal cable and connected jumper wires are on separate connected terminals.

2.2.7.6.4. Rack Mounted Terminal Blocks

2.2.7.6.4.1. Terminal blocks shall be rack mounted wire termination units consisting of insulation displacement connectors (IDC) mounted in plastic blocks, frames or housings.

2.2.7.6.4.2. Blocks shall be type 110 IDC that meet the requirements of ANSI/TIA/EIA-568-b.2.

2.2.7.6.4.3. Blocks shall include cable management hardware above and below.

2.2.7.6.5. **Wall Mounted Terminal Blocks**

2.2.7.6.5.1. Terminal blocks shall be wall mounted wire termination units consisting of insulation displacement connectors mounted in plastic blocks, frames or housings.

2.2.7.6.5.2. Blocks shall be type 66 split 50 blocks, typically mounted on a telecommunications backboard to allow interface to voice service demarcations.

2.2.7.6.5.3. In certain applications with BSCO approval, type 110 IDC blocks may be used, meeting the requirements of ANSI/TIA/EIA-568-b.2 for the applicable category rating.

2.2.8. **Patch Cables**

2.2.8.1. Patch cables shall be cable assemblies consisting of flexible, twisted pair wire of the same category rating as the system they serve and shall meet the requirements of EIA ANSI/TIA/EIA-568-b.

2.2.8.2 Use only cable that has passed the Underwriters Laboratory (UL) LAN certification program and is labeled with UL acceptable markings indicating performance level of cable.

2.2.8.3. Copper patch cables must be 4-pair, 24 AWG, stranded UTP cable, with 8-pin modular connectors at each end.

2.2.8.4. Patch cables shall be wired straight through; pin numbers shall be identical at each end and shall be paired to match T568A patch panel jack wiring per EIA ANSI/TIA/EIA-568-b.1.

2.2.8.5. Provide sufficient copper patch cables, of various appropriate lengths, to terminate all copper patch panel appearances.

2.2.8.5.1. Provide blue patch cables for voice service.

2.2.8.5.2. Provide green patch cables for network service.

2.2.8.5.3. Provide 16ft gray station cables to terminate all copper work area outlet locations.

2.2.8.6. Patch cables shall be keyed (non-booted) and factory assembled.

2.2.8.7. Provide blue patch cords, solid conductor with an eight-position plug on at least one end, for analog service connectivity to the rack-mounted punch block.

2.3. **FIBER OPTIC CABLE (FOC) SYSTEM**

2.3.1. **Fiber Optic Cabling** Multimode fiber optic backbone cable shall be run from Main Distribution Frame (MDF) to Intermediate Distribution Frame (IDF) for networking connectivity to government identified demarcation point.

2.3.1.1. Numerical aperture for each fiber shall be a minimum of 0.275.

2.3.1.2. Cable construction shall be tight-buffered type.

2.3.1.3. Maximum attenuation for indoor multi-mode fiber-optic cabling shall meet the ANSI/TIA/EIA-568-B.3 Specifications for 12 strand, 62.5/125 micrometer multimode graded index optical fiber cable.

2.3.1.4. All horizontal fiber optic cable shall be run in Innerduct or shall be have an armor jacket.

2.3.1.5. Use only cable that has passed the Underwriters Laboratory (UL) LAN certification program and is labeled with UL acceptable markings indicating performance level of cable.

2.3.1.6. Cable shall be rated Plenum (OFNP) per NFPA 70.

2.3.1.7. Cable shall be imprinted with fiber count and aggregate length at regular intervals.

2.3.1.8. Individual fibers shall be color coded for identification.

2.3.2. Connecting Hardware

2.3.2.1. Fiber Optic (FO) Outlet/connector

2.3.2.1.1. Terminate all FO work area cables in dual 568SC connectors unless may be substituted as required by the user with approval from the CO and concurrence by the BCSO.

2.3.2.1.2. Provide FO connectors in accordance with the paragraph entitled "Fiber Optic (FO) Terminations" in this standard.

2.3.2.1.3. The default choice for FO outlet/connector must be TIA/EIA "SC" type (568SC), with a maximum insertion loss of .5 db.

2.3.2.1.4. Multimode FO Connectors shall meet performance requirements of EIA ANSI/TIA/EIA-568-b.3. and EIA ANSI/TIA/EIA-526-14A.

2.3.2.1.5. Connectors shall be field installable.

2.3.2.1.6. Connectors shall utilize adhesive for fiber attachment to ferrule.

2.3.2.1.7. Connectors shall terminate fiber sizes as required for service.

2.3.2.2. Fiber Optic (FO) Termination

2.3.2.2.1. Contractor should not use ST style adapters for new construction unless specifically required for interface with existing equipment reused on installations. Check with activity for specific requirements for ST adapters.

2.3.2.2.2. Provide FO adapters and connectors in accordance with TIA/EIA-604.

2.3.2.3. Fiber Optic (FO) Patch Panels

2.3.2.3.1. Patch panels shall be a complete system of components by a single manufacturer, and shall provide termination, splice storage, routing, radius limiting, cable fastening, storage, and cross-connection.

2.3.2.3.2. Patch panels shall be 19-in. rack mounted panels unless otherwise specified in by the CO.

2.3.2.3.3. Patch panel connectors and couplers shall be SC type for termination for connectivity in patch panels, with ceramic ferrule material with a maximum insertion loss of .5 db.

2.3.2.3.4. Patch panel connectors and couplers must be the same type and configuration as used elsewhere in the system.

2.3.2.3.5. Utilize 568SC duplex connectors on 19-in. (475 mm) rack mounted panels, unless otherwise directed.

2.3.2.3.6. Provide a maximum panel size of 12 SC or 24 ST ports for fiber panels.

2.3.2.4. Innerduct

2.3.2.4.1. Innerduct shall be U.L. Listed, non-metallic corrugated flexible raceway used to protect and route fiber-optic cables in the horizontal cable routes.

2.3.2.4.2. Innerduct shall be plenum rated in accordance with the NPFA 70.

2.3.2.4.3. All couplers and adapters shall be of the same manufacturer as the Innerduct and shall be installed in accordance with manufacturer's specifications.

2.3.2.5. Fiber Optic (FO) Patch Cables shall be provided by other unless specified by the CO.

2.4. EQUIPMENT RACKS

2.4.1. Floor Mounted Open Frame

2.4.1.1. Equipment racks must be floor mounted, standard 19-in. (475 mm) aluminum relay racks, uprights shall be 3-in. deep, 1 ¼-in. wide, drilled and tapped #12-24 in a half-inch pattern.

2.4.1.2. Racks shall be provided with a standard top crossmember, and predrilled base plate to allow floor fastening.

2.4.1.3. Open frame equipment racks shall be 7-ft in height and clear coated.

2.4.1.4. Wall mounted racks may be utilized in small buildings or for small systems.

2.4.2. Wall Mounted Swing Cabinet

2.4.2.1. Wall Mounted Swing Cabinet shall have smoke-colored plexiglass front door, hinged, with dual key locks.

2.4.2.2. The cabinet main chassis shall be hinged to the back of the enclosure, allowing access to the back of the systems being installed.

2.4.2.3. The cabinet main chassis shall be secured to the back enclosure with dual key locks and a latch system.

2.4.2.4. Both front and rear hinging systems shall be universal allowing the frame to be mounted to open from the left or the right.

2.4.2.5. The cabinet sides shall be vented.

2.4.2.6. The cabinet shall provide standard 19-in. mounting rails, adjustable front to back, drilled and tapped for both #10-32 and #12-24 a half-inch pattern.

2.4.2.7. Cabinet shall be equipped with cooling fans with protective safety covers.

2.4.2.8. Cabinet must be at least 24-in. deep to support equipment dimensions.

2.4.2.9. Cable access ports shall be provided on the top and the bottom of the enclosure with plugs included.

2.4.3. Cable Management

2.4.3.1. Cable management shall be specifically manufactured for the purpose of routing cables, wires and patch cords horizontally and vertically on standard 19-inch equipment racks.

2.4.3.2. Cable management shall consist of a type that utilizes duct fingers with snap on, hinged covers.

2.4.3.3. Cable management shall mount to racks by screws and/or nuts and lockwashers.

2.4.3.4. Cable management shall be provided above, below and to both sides of each patch panel on the standard 19-inch equipment rack(s).

2.4.3.5. Vertical cable management will be provided between and to the ends of equipment racks, and provide front and rear vertical cable management.

2.4.3.6. Cable management will be provided in the rear of the rack, utilizing duct fingers with snap on, hinged cover style, or stand-off bars.

2.4.3.7. Velcro ties shall be utilized for binding of horizontal distribution wires within the telecommunications room trays and wire management systems.

2.5. EQUIPMENT MOUNTING BACKBOARD A minimum of one wall shall be covered with rigidly fixed ¾-in. (20mm) A-C rated plywood. Plywood backboards shall be void free, 4-ft by 8-ft. Plywood must be fire-rated or painted with gray colored fire resistive paint on all six sides. Anchoring and mounting techniques of plywood used to support backbone riser cables shall be sufficient to support a minimum of 1500 pounds of weight. In no cases shall the heads of mounting screws protrude past the face of the plywood.

2.6. TELECOMMUNICATIONS OUTLET BOXES Electrical boxes for telecommunication outlets shall be 4-11/16-in. (119 mm) square by 2-1/8-in. (54 mm) deep with minimum 3/8-in. deep single or two gang plaster ring as shown in provided design drawings. All outlet boxes are to receive Quad jack installation unless otherwise indicated. Provide a minimum 1-in. (27 mm) conduit stubbed above the false ceiling or to the cable tray.

2.7. TELECOMMUNICATIONS ROOM REQUIREMENTS TRs shall be designed and provisioned according to the requirements in ANSI/EIA/TIA-569-A.

2.7.1 Telecommunications Room Sizing TRs must be an appropriate size to accommodate the proposed cable/LAN distribution system and associated connectivity equipment for any given facility and/or facility floor. The minimum size TR for system installation is 8-ft by 10-ft, avoiding irregular sized TRs, such as narrow rooms or odd shapes. If any additional equipment/racks are placed in a TR, the TR must be enlarged to accommodate.

2.7.2. Sizing for Tenant Equipment Provide adequate space in TRs to facilitate tenant owned telecommunications system support equipment requirements in tenant installed freestanding cabinets or racks.

2.7.3. Clearance and Spacing A minimum safety clearance distance of 36-in. shall be maintained between wall, or any wall mounted devices, and the equipment to be installed in the communications rack assembly.

2.7.4. Dedicated Space TRs must be dedicated spaces not shared with other functions (i.e., electrical rooms, mechanical rooms, etc).

2.7.5. Environmental Requirements Connecting hardware shall be rated for operation under ambient conditions of 32 to 140 degrees F and in the range of 0 to 95 percent relative humidity, non condensing. The optimal temperature range for each TR shall be 65 - 77 degrees F to support Network accreditation requirements.

2.7.6. Room Climate Control Each TR must be independently climate controlled, capable of providing year round ambient temperature control (24 hours/day, 365 days/year) to protect all installed electronic equipment.

2.7.6.1. Dedicated Ventilation Air Conditioning systems support must be provided for each TR.

2.7.6.2. Systems must be of an appropriate capacity to self-support the room, taking into account the heat load of proposed equipment installation requirements.

2.7.6.3. Ventilation Air Conditioning systems must not take up any floor space within the TR.

2.7.6.4. A dedicated 20 Amp circuit for the use of Ventilation Air Conditioning system.

2.7.6.5. TRs must be provided with positive atmospheric pressure to exclude dust.

2.7.7. **Room Interior Finishes** Floors, walls, and ceilings must be treated to eliminate dust. Finishes shall be light in color to enhance room lighting.

2.7.8. **Room Lighting** Light fixtures must be mounted a minimum of 9-ft (3m) above the finished floor and provide a minimum of 50 foot candles (500 lx) of illumination measured 3-ft (1m) above the finished floor. Light fixtures shall be positioned to provide maximum lighting to the room (placing light fixtures directly over cable trays or equipment racks should be avoided because the lighting will be obstructed).

2.7.9. **Room Door** TR doors must be a minimum of 36" (1m) wide, 80" (2m) tall, without doorsill, hinged to open outward into the hallway, or additional room square footage must be added to the floor space to accommodate interior door swing. TR doors must be fitted with a lock to control access to the room. The TR door lock shall be keyed with the standard CES/COMM Maintenance Key (typically known as an MTM key).

2.7.10. **Room Contaminants** Information system equipment must not be installed in spaces where moisture, liquid or gaseous spillage, or other contaminants may be present.

2.7.11. **Power Requirements** Provide a minimum of two dedicated un-switched 20-amp, 120-VAC duplex receptacle power outlets, each on a separate branch circuit, for telecommunication equipment. Increase these minimum requirements as necessary to meet equipment loads. Provide a dedicated 20-amp circuit and a quadraplex receptacle for each 19 in (480 mm) rack or cabinet. Additional convenience receptacles must be provided at 6 ft (1800 mm) intervals around the perimeter walls.

2.7.12. **Telecommunications Outlets** Two (2) Telecommunications Quadra-plex outlets shall be provided in the TR, on the walls parallel to the equipment rack line-up.

2.8. Miscellaneous Products

2.8.1. Surface Mounted Non Metallic Raceway

2.8.1.1. All surface raceway shall be of a single channel design or dual channel when electrical wiring is run in the raceway. Raceway shall be manufactured from impact-resistant material, or metallic, with a flammability rating of U.L. 94V-0.

2.8.1.2. Contractor is to match color as close as possible the aesthetics of the office environment of the installation site. Raceway finish shall be pure color and will resist scratches and dents and will not peel or corrode. Contractor must receive approval from the CO prior to installation of surface raceway.

2.8.1.3. All surface raceway shall have a full compliment of bend radius control and standard fittings including, but not limited to: elbows (internal & external), couplings for joining raceway sections, blank end fittings for closing open ends of the raceway, and tee fittings.

2.8.1.4. All surface raceway shall incorporate a minimum 1" bend radius as recommended for Category 6 UTP & fiber optic cables.

2.8.1.5. Contractor must prove that other components such as surface boxes, faceplates, etc. are of the same manufacturer and compatible with the surface raceway provided.

2.8.1.6. Standard of quality shall be Hellermann Tyton or equivalent.

2.8.2. **Tele/Power (Utility) Pole** Provide a Tele/Power Pole System to extend communication cabling to points of use to support systems furniture. Tele/Power Pole System shall consist of pole multi-outlet assemblies, and appropriate fittings and accessories as required for a complete assembly.

2.8.2.1. The Tele/Power Pole must be constructed specifically for use with the systems furniture.

2.8.2.2. If electrical service is to be shared in the Tele/Power Pole, a dual compartment with a metallic barrier separating telecommunications cables from electrical cables must be provided in accordance with NFPA 70.

2.8.2.3. The Tele/Power Pole shall be provided with knockouts for a minimum of two (2) duplex, eight-position, surface-mount jacks

2.8.2.4. Surface mount boxes mounted to power poles are not acceptable.

2.8.2.5. The contractor is required to seek final approval from the CO in conjunction with the BCSO on the selection of a Tele/Power pole type and color.

2.8.3. **Firestop** The contractor shall Fire stop all sleeves and conduit openings after the cable installation is complete in accordance with applicable fire and safety code and manufacturer specifications.

PART 3 EXECUTION

3.1. **INSTALLATION** System components and appurtenances shall be installed in accordance with NFPA 70, manufacturer's instructions and as shown. Necessary interconnections, services, and adjustments required for a complete and operable signal distribution system, from the facility's government provided outside plant demarcation point, shall be provided. Components shall be labeled in accordance with EIA ANSI/TIA/EIA-606 and LAFB standard labeling scheme. Penetrations in fire-rated construction shall be fire stopped in accordance with specifications. Conduits, outlets and raceways shall be installed in accordance with EIA ANSI/TIA/EIA-569-A, Telecommunications Pathways and Spaces. Wiring shall be installed in accordance with EIA ANSI/TIA/EIA-568-b.1, b.2. Wiring, terminal blocks, and outlets shall be marked in accordance with EIA ANSI/TIA/EIA-606. Cables shall not be installed in the same cable tray, utility compartment, or floor trench compartment with AC power cables. Cables not installed in conduit or wireways shall be properly secured, per industry standard, and neat in appearance and, if installed in plenums or other spaces used for environmental air, shall comply with NFPA 70 requirements for this type of installation. Cable tray installation shall be provided for complete wire support within the TR, from room entrance to overhead rack area, providing complete cable support, when overhead wire installation methods are utilized.

3.1.1. Horizontal Distribution Cable

3.1.1.1. Horizontal cable length must be limited to 295-ft (90m) from patch panel termination in the TR to the work area outlet termination in accordance with TIA/EIA-568-B.1. All horizontal wiring must be designed in a star-configuration as defined in TIA/EIA-568-B.1.

3.1.1.1.1. The maximum pulling tensions for 4-pair 24 AWG horizontal UTP cables shall not exceed 25 lbf to avoid stretching the conductors during installation.

3.1.1.1.2. Cable management precautions shall be observed to include the elimination of cable stress as caused by tension in suspended cable runs and tightly cinched cable bundles.

3.1.1.1.3. Cable shall not be stressed such that twisting, stretching or kinking of cable during installation.

Cable shall not be spliced.

3.1.1.1.4. Cables shall be installed in conduit, cable trays, or other industry approved hanger assemblies as EIA ANSI/TIA/EIA-568-b.2 recommends.

3.1.1.1.5. Cable shall not be run through structural members or in contact with pipes, ducts, or other potentially damaging items.

3.1.1.1.6. Placement of cable parallel to power conductors shall be avoided, if possible; a minimum separation of 12-in. shall be maintained when such placement cannot be avoided.

3.1.1.1.7. Minimum bending radius shall not be exceeded during installation or once installed.

3.1.1.1.8. Cable ties shall not be excessively tightened such that the transmission characteristics of the cable are altered.

3.1.1.1.9. Cable and conductors shall sweep into termination areas.

3.1.1.1.10. Cable and conductors shall not bend at right angles.

3.1.1.2. Horizontal Distribution Cable Termination

3.1.1.2.1. The amount of untwisting in a pair as a result of termination to connecting hardware shall not exceed 0.5-in. for UTP cables from IDC.

3.1.1.2.2. An additional practice that shall be followed to reduce untwisting of pairs, is to strip back only as much cable jacket as required to terminate on connecting hardware.

3.1.1.2.3. When there are multiple system type drops to individual workstations, relative position for each system shall be maintained on each system termination block or patch panel.

3.1.1.2.4. Also, in spaces with UTP terminations, cable bend radi shall not be less than four times the cable diameter for horizontal cable and shall not be less than ten times the cable diameter for multi-pair cable.

3.1.1.3. **Raised Floors** Cable 6-ft long shall be neatly coiled in a figure-eight configuration not less than 12-in. in diameter below each feed point in raised floor areas, if applicable.

3.1.1.4. Horizontal Distribution Maintenance Loop

3.1.1.4.1. Maintenance loop or slack required for modification or re-termination of horizontal cabling shall be no less than 10-ft (3m), at the distribution closet and no less than 24-in. (30cm) at the outlet.

3.1.1.4.2. Maintenance loop shall be provided on the cable tray above the equipment racks in the TR Slack at the user termination shall not be placed in the outlet box, but shall be installed at the nearest practical point to the outlet box (i.e. above the ceiling prior to entering the wall).

3.1.1.4.3. Slack at the user termination shall be provided in a figure eight configuration.

3.1.2. Riser and Backbone Cable

3.1.2.1. Vertical cable support intervals shall be in accordance with manufacturers' recommendations. Cable bend radius shall not be less that ten times the outside diameter of the cable during and after installation.

3.1.2.2. Maximum tensile strength rating of the cable shall not be exceeded.

3.1.2.3. Cable shall not be spliced.

3.1.2.4. Maintenance loop or slack required for modification or re-termination of backbone cabling shall be no less than 10-ft (3m), at both ends of termination.

3.1.2.5. Provide at least two backbone cable pairs for every outlet connected to the TR served by the backbone cable.

3.1.2.6. The building backbone must have no more than two hierarchical levels of cross-connects.

3.1.2.7. The copper backbone cable originating in the main TR or main cross connect must be terminated in each TR insulation displacement, wiring blocks mounted on the telecommunications backboard.

3.1.2.8. All backbone wiring must be designed in a star-configuration as defined in TIA/EIA-568-B.1.

3.1.3. Telecommunication Outlets

3.1.3.1. Outlet Faceplates

3.1.3.1.1. Faceplates shall be clean and free of paint, marks, or smudges.

3.1.3.1.2. Faceplates shall be installed parallel to the floor and other linear décor and not crooked.

3.1.3.1.3. Use a full (double gang) faceplate for standard administrative outlet locations, with connectors for all copper and (if used) FOC.

3.1.3.1.4. Standard administrative outlets may, by specific user request, use single gang outlet faceplates in conjunction with a reducing ring.

3.1.3.1.5. For single gang outlet boxes, use a single gang outlet faceplate with appropriate connector locations and, if required, mounting lugs for wall phones.

3.1.3.1.6. As a minimum each jack shall be labeled as to its function and a unique number to identify cable link, as per LAFB standard labeling scheme.

3.1.3.2. Outlet Location and Density

3.1.3.2.1. Outlet locations, when placed on a fixed wall, shall be located 18" Above Finished Floor (AFF) or at a height equal to existing electrical outlets in the room, when applicable.

3.1.3.2.2. Outlet densities for all administrative facilities and administrative spaces shall be equipped with one standard telecommunications outlet for each 48 square feet (4.5 square meters) of net office space.

3.1.3.2.3. Outlet densities and locations for all special-purpose spaces and non-administrative facilities must be determined by the user and approved by the CO in conjunction with the BCSO and must follow the guidelines in TIA/EIA-569-B.

3.1.3.2.4. Special consideration shall be given to the placement of outlets to accommodate systems furniture designs.

3.1.3.2.5. When placing outlets in a raised floor setting, jacks shall be placed in recessed floor gang boxes that provide appropriate accessibility and protection of outlets.

3.1.3.3. **Pull Cords** Pull cords shall be installed in all conduits serving telecommunications outlets, which do not initially have FOC installed.

3.1.4. Terminal Blocks

3.1.4.1. Terminal blocks shall be mounted on orderly rows and columns.

3.1.4.2. Adequate vertical and horizontal wire routing areas shall be provided between groups of blocks.

3.1.4.3. Terminal Blocks shall include cable management hardware on either side at the corners of the terminal block mounted horizontally and one mounted vertically a few inches below each row of blocks.

3.1.4.4. Wall mounted 66-type terminal blocks shall be utilized at the Main Distribution Frame (MDF) or Demarcation Point for outside plant copper cross connect capability.

3.1.4.5. Rack mounted 110 IDC terminal blocks will be used as the Intermediate Distribution Frame (IDF) point (Patch Panel end) for copper backbone cable cross connects.

3.1.4.6. Cable Management Hardware for wall mounted terminal blocks is usually provided as "D" rings type. Cable Management Hardware shall be sized for the application provided. Wire spools shall not be used for cable distribution systems serving greater than 100-pairs.

3.1.5. Patch Panels

3.1.5.1. Unshielded Twisted Pair Patch Panels

3.1.5.1.1. Patch panels shall be mounted in equipment racks with sufficient modular jacks to accommodate the installed cable plant plus 25 percent spares for future expansion.

3.1.5.1.2. Cable management will be provided above, below, between, and to both sides of each panel, to include the front and rear of rack, and patch Panel assembly.

3.1.5.2. Fiber Optic (FO) Patch Panels

3.1.5.2.1. Patch panels shall be mounted in the top of the center equipment rack or cabinet (under the OSP fiber patch panel or with space reserved for the OSP fiber patch panel), with sufficient ports to accommodate the installed cable plant.

3.1.5.2.2. A slack loop of fiber shall be provided within each panel. Loop shall be 3-ft in length or longer if recommended by the manufacturer.

3.1.5.2.3. The outer jacket of each cable entering a patch panel shall be secured to the panel to prevent movement of the fibers within the panel, using clamps or brackets specifically manufactured for that purpose.

3.1.5.2.4. FO Patch Panels providing facility service shall be installed at the top (or sufficient space reserved if provided by other) with backbone FO Patch Panels provided under the OSP FO Patch Panel.

3.1.5.2.5. Each fiber shall be terminated to the Contractor supplied patch panel, using applicable connectors. No fiber will be left un-terminated.

3.1.5.2.6. Panels shall be labeled per LAFB standard labeling scheme.

3.1.5.3. Fiber Optic Cables (FOC)

3.1.5.3.1. Terminate all FO work area cables in dual 568SC connectors unless may be substituted as required by the user with approval from CO and concurrence from the BCSO.

3.1.5.3.2. All FO backbone cable must be terminated in cabinet/rack-mounted patch panels, at each end.

3.1.6. Telecommunications Equipment Racks

3.1.6.1. Floor Mounted Equipment Racks

3.1.6.1.1. Open frame equipment racks shall be bolted to the floor.

3.1.6.1.2. Cable management shall be bolted or screwed to racks.

3.1.6.1.3. Racks shall be installed level, and ganged racks shall be bolted together (with cable management mounted in between racks).

3.1.6.1.4. Open frame equipment racks shall be secured per industry standards to prevent racking or swaying.

3.1.6.1.5. AC outlets shall be provided in the equipment rack to prevent tripping, one quad outlet dedicated 20 Amp line assembly, per every two equipment racks provided and labeled with the applicable circuit breaker number.

3.1.6.1.6. Equipment racks shall be located at or near the center of the TR.

3.1.6.1.7. Equipment racks must provide a minimum 36-in. (900 mm) space both in front and in back of the rack, behind any installed equipment, and a minimum side clearance of 24-in. (600 mm) on end racks.

3.1.6.1.8. In smaller TRs, equipment racks may be floor mounted adjacent to a wall.

3.1.6.1.9. Provide 100% spare rack capacity based on the amount of rack capacity utilized by the patch panels provided.

3.1.6.1.10. Spare racks must be provided for the mounting of government purchased and installed LAN equipment.

3.1.6.2. Wall Mounted Equipment Racks

3.1.6.2.1. Wall mounted, swing out racks shall be provided in special instances where TR floor space does not allow proper safety clearance per NPFA 70.

3.1.6.2.2. Wall mounted racks shall be secured to the mounting surface to prevent fully loaded racks from separating from the mounting surface.

3.1.6.2.3. No more than two wall mounted racks shall be installed in the same ganged rack assembly.

3.1.6.2.4. Ganged wall mounted racks shall be hinged to the inside of the ganged racks to allow fully loaded racks to swing open.

3.1.6.2.5. Proper safety clearance must be provided in front of the equipment rack and when the rack is opened for access to the back of the systems with the chassis opened.

3.1.7. Telecommunications Equipment Cabinets

3.1.7.1. Floor Mounted Equipment Cabinets

3.1.7.1.1. Equipment cabinets shall be provided in special instances where physical security is required, to mount secure or mission critical equipment, in circumstances where controlled access is desired, distribution in military housing, or by specific user request.

3.1.7.1.2. Cable may be terminated in an enclosed 19-in. (475mm) cabinet to provide enhanced protection for terminations and patching facilities.

3.1.7.1.3. Cabinets must provide, at a minimum, sufficient space for current and anticipated future equipment requirements.

3.1.7.1.4. Equipment cabinets may be floor or wall mounted and should be logically grouped based on the purpose of the equipment they enclose.

3.1.7.1.5. Cooling fans must be provided in all equipment cabinets.

3.1.7.1.6. Cabinets shall be installed level, and ganged cabinets shall have adjacent side panels removed.

3.1.7.1.7. Equipment Cabinets shall be secured per industry standards.

3.1.7.1.8. Proper safety clearance must be provided in front and back of the equipment cabinet.

3.1.7.2. **Wall Mounted Equipment Cabinets**

3.1.7.2.1. Wall mounted, swing out cabinets shall be provided in small applications and special instances where TR floor space does not allow proper safety clearance per NPFA 70.

3.1.7.2.2. Wall mounted cabinets shall be secured to the mounting surface to prevent fully loaded racks from separating from the mounting surface.

3.1.7.2.3. Wall mounted cabinets shall be mounted to manufacture specifications and industry standards.

3.1.7.2.4. Proper safety clearance must be provided in front of the equipment cabinet and when the cabinet is opened for access to the back of the systems with the chassis in opened.

3.1.7.2.5. The cabinet height shall be sized to support premise wiring distribution system requirements with 25% spare capacity.

3.1.7.2.6. AC outlets shall be provided in the cabinet to provide power for equipment, one quad outlet dedicated 20 Amp line assembly, per every cabinet provided.

3.1.8. **Rack Mounted Equipment** Equipment to be rack mounted shall be securely fastened to racks by means of the manufacturers recommended fasteners.

3.1.9 **Building Infrastructure** In new construction, particularly in large administrative or medical facility buildings, cable distribution systems must use the cable tray (or duct) and conduit systems as described. In new construction involving small, mixed use (non administrative) facilities, or construction projects involving renovation of existing buildings, use of "J" hooks, flexible cable tray, and alternative support systems specifically certified for horizontal cable is permissible.

3.1.9.1. **Ladder and Wire Cable Tray**

3.1.9.1.1. Ladder type or welded wire cable tray must be used in the TR to provide distribution between the telephone backboard, equipment racks, backbone conduits, and the distribution cable tray.

3.1.9.1.2. Cable trays shall be designed to accommodate a maximum calculated fill ratio of 50% to a maximum inside depth of 6 in (150 mm).

3.1.9.1.3. Provide 12-in. of clearance above cable trays for future access.

3.1.9.1.4. Coordination with other disciplines must take place to insure proper clearances are provided.

3.1.9.2. **Conduit**

3.1.9.2.1. Electrical Metallic Tubing (EMT) Conduit for standard outlets must be a minimum of 1-in. (27mm) EMT conduit.

3.1.9.2.2. No more than four, four-pair cables may be in a 1-in. (27mm) conduit.

3.1.9.2.3. Conduit bend radii must be coordinated with cable bend radius.

3.1.9.2.4. Conduit entries at outlet and junction boxes must be arranged so that cables passing through the box must enter and exit at opposite sides of the box.

3.1.9.2.5. An optimal conduit fill ratio of 40% should be accommodated for conduit. Under no circumstances should the designer exceed a fill ratio of 50%.

3.1.9.2.6. Do not use metal flex conduit for telecommunications wiring except when installing floor-access boxes in a raised floor, where floor-access box must be relocated within a specified service area: i.e., 15-20 foot radius typical.

3.1.9.3. Pull Boxes

3.1.9.3.1. Pull boxes must be placed in conduit runs where a continuous conduit length exceeds 100-ft, or where there are more than two 90-degree bends.

3.1.9.3.2. Pull boxes must be placed in straight runs of conduit and not be used in lieu of a bend.

3.1.9.4. Raceway

3.1.9.4.1. Surface mounted non-metallic raceway may be used in renovation projects where access to the walls for installation of conduit and outlet boxes is not possible, or where historical requirements prohibit the alteration of the building structure.

3.1.9.4.2. Securely install all surface raceway by using proper installation screws into walls. Screws shall be within 2-in. of the top and bottom of each end and shall have mounting screws at 18-in. intervals.

3.1.9.5. Innerduct installed shall include pre-installed pull tape.

3.2. **TERMINATIONS** All cables shall be neatly “dressed out” in equipment rooms. Cable and conductors shall sweep into termination areas. Cable and conductors shall not bend at right angles. When there are multiple system type drops to individual workstations, relative position for each system shall be maintained on each system termination block or patch panel. Also, in spaces with UTP terminations, cable bend radii shall not be less than four times the cable diameter for horizontal cable and shall not be less than ten times the cable diameter for multi-pair cable.

3.2.1. Unshielded Twisted Pair Cable

3.2.1.1. Each pair shall be terminated on appropriate outlets, terminal blocks or patch panels.

3.2.1.2. No cable shall be un-terminated or contain un-terminated elements.

3.2.1.3. Pairs shall remain twisted together to within the proper distance from the termination as specified in EIA ANSI/TIA/EIA-568-b.2.

3.2.1.4. An additional practice that shall be followed to reduce untwisting of pairs, is to strip back only as much cable jacket as required to terminate on connecting hardware.

3.2.1.5. Conductors shall not be damaged when removing insulation. Wire insulation shall not be damaged when removing outer jacket.

3.2.2 **Fiber Optic Cable (FOC)** Each fiber shall be terminated to the Contractor supplied patch panel, using applicable connectors. No fiber will be left un-terminated.

3.2.3. Open Office Wiring

3.2.3.1. Systems Furniture Wiring

3.2.3.1.1. Systems furniture wiring connections must be designed in accordance with TIA/EIA-568-B and TIA/EIA-569-B.

3.2.3.1.2. Systems furniture wiring designed must be approved by the CO and concurrence from the BCSO.

3.2.3.1.3. Systems Furniture must provide a dedicated channel/pathways for routing communications cables.

3.2.3.1.4. Systems Furniture communications channels must provide easy access to install and maintain communications cables.

3.2.3.1.5. Communications cable must be protected at all transition points, and that metallic separation is provided between telecommunication and power wiring in the power pole and/or systems furniture track in accordance with TIA/EIA-569-B 10.3 and Article 800-52 of NFPA 70.

3.2.3.1.6. Direct connection, from the TR patch panel to the communications outlet in the systems furniture, must not be used.

3.2.3.1.7. Use, to the maximum extent possible, communications outlets installed on permanent structures, such as walls or pillars, to provide communications service to systems furniture.

3.2.3.1.8. A minimum of two communications outlets per single occupancy systems furniture cubicle must be provided. However, additional outlets must be provided to accommodate network printers, fax machines, copiers, secure telephones, and other specialized systems/devices. As a general rule, provide a ratio of 2.25 communications outlet capacity per single occupancy systems furniture cubicle to support these specialized systems/devices when the exact quantity or location is not provided.

3.2.3.1.9. Use tele/power poles or similar assemblies to provide communications service to systems furniture which can not be serviced, or is impractical to service, from communications outlets provided on a permanent structure.

3.2.3.3. **Communications (Utility) Pole**

3.2.3.3.1. The Communications pole must be constructed specifically for use with the systems furniture being installed or provided and shall be equivalent in size, structure, materials, and color as existing poles.

3.2.3.3.2. Communications poles shall be secured to the floor and ceiling per manufacture standards and provide the ability to be relocated at a later date.

3.2.3.3.3. Provide 10ft of slack as a maintenance loop coiled in a figure-eight and secured above the ceiling over the communications pole.

3.2.3.3.4. Provide knockouts for a minimum of two (2) duplex, eight-position, surface-mount jacks. Surface mount boxes mounted to power poles are not acceptable.

3.2.3.4. **Multi-User Telecommunication Outlet Assembly (MUTOA)** MUTOAs may be provided in an open office environment that is planned to be frequently reconfigured so that each furniture cluster is served by at least one MUTOA. MUTOAs may be provided in an open work area MUTOA application and design must follow the guidance of TIA/EIA-568-B.1.

3.2.3.4.1. MUTOAs shall be located in fully accessible, permanent locations such as building columns, and permanent walls. MUTOAs shall not be located in ceiling spaces, or obstructed areas. MUTOAs shall not be installed in furniture unless that unit of furniture is permanently secured to the building structure.

3.2.3.4.2. The MUTOA must be limited to serving a maximum of twelve (12) users. Measurements for Systems Furniture must take into account the dimensions of the MUTOAs planned to be provided in a given open office environment. Spare capacity should be considered when sizing the MUTOA.

3.2.3.4.3. Do not exceed the horizontal cable length requirements. The maximum lengths for copper cabling in the context of MUTOAs and open office furniture, shall meet the requirements of ANSI/TIA/EIA-568-B-2.

3.2.3.5. **Consolidation Point (CP)** CPs may be provided in an open office environment where it would be most advantageous to utilize an interconnection point within the horizontal cabling. CPs should be located in an open work area so that each furniture cluster is served by at least one CP.

3.2.3.5.1. CPs shall be located in fully accessible, permanent locations such as building columns, and permanent walls. CPs shall not be located in ceiling spaces, or obstructed areas. CPs shall not be installed in furniture unless that unit of furniture is permanently secured to the building structure.

3.2.3.5.2. CPs shall be provided in accordance with TIA/EIA-568-B.2 or TIA/EIA-568-B.3 utilizing compliant connecting hardware rated for at least 200 cycles of reconnection.

3.2.3.5.3. No more than one consolidation point shall be used in the same horizontal cable run. A transition point and consolidation point shall not be used in the same horizontal-cabling link.

3.2.3.5.4. The CP must be limited to serving a maximum of twelve (12) work areas. Do not exceed the horizontal cable length requirements. Spare capacity should be considered when sizing the CP.

3.2.3.6. **Utility Rooms and Closets** All utility rooms and closets, such as electrical, mechanical and telecommunications, must be wired with at least one wall mounted telecommunications outlet, with a mounting lug face plate.

3.2.3.7. **Elevators** For buildings with elevators, a four-pair copper cable with an eight-position modular outlet adapter must be installed for each elevator. The exact location of the outlet assembly must be verified with the elevator installer or Contractor.

3.2.3.8. **Safety, Courtesy, & Convenience** Provide wall outlets at all logical locations to support safety, courtesy, & convenience. Examples for safety include: dormitory dayrooms, laundry room; examples for courtesy include: building lobby, entrance, or waiting area; examples for convenience include: break rooms, rear (unmanned) entrances.

3.2.3.9. **Building Automation Systems** Provide wall outlets at specified locations to support building automation systems as identified by Civil Engineering planners. For example, one such outlet may be a direct digital controller (DDC) outlet (or Environmental Management Control System (EMCS)) for the HVAC system.

3.3. BONDING AND GROUNDING

3.3.1. **Telecommunications Room Signal Ground** All unclassified TRs must be connected to the building earth electrode subsystem (EES) in accordance with J-STD-607-A.

3.3.1.1. The Telecommunications Main Grounding Busbar (TMGB) shall be tied to the building EES with a two-hole compression lug fittings and at least a #2 AWG Telecommunications Bonding Backbone (TBB).

3.3.1.2. TMGB with stand off insulators shall be tied to the Telecommunications Grounding Busbar (TGB) with a two-hole compression lug fittings and at least a #4 AWG TBB.

3.3.1.3. The size of the grounding electrode conductor of a grounded system shall be at least a #6 AWG TBB and sized in accordance with J-STD-607-A.

3.3.1.4. The signal grounding system shall not interconnect with the fault protection and lightning protection sub-systems within the building.

3.3.1.5. Bonding and grounding system shall be tested per ANSI/TIA/EIA and NFPA 70 standards.

3.3.1.6. Bonding and grounding system shall be labeled per ANSI/TIA/EIA and LAFB standard labeling scheme.

3.3.1.7. All telecommunications racks and supporting structures (cable trays, ladders, conduits and baskets) within a TR must be bonded to the TGB or TMGB as defined in J-STD-607-A.

3.3.2. Telecommunications Rack and Supporting Structure

3.3.2.1. All telecommunications racks and supporting structures (cable trays, ladders, conduits and baskets) within a TR must be bonded to the TR signal ground ring or bus bar as defined in and TIA/EIA-569-B (TGB or TMGB as defined in J-STD-607-A).

3.3.2.2. The Equipment Racks shall be bonded together using Compression Lugs and green-jacketed 6 AWG Stranded Copper.

3.3.2.3. Equipment racks shall be connected to the electrical safety ground only if a separate earth ground is not available.

3.3.2.4. Deviations to these standards shall be submitted to the CO for review and approval by the BCSO.

3.3.3. Cable Entrance Grounding

3.3.3.1. All metallic shields and strength members for outside plant cable entering a building must be connected to the lightning protection ground system.

3.3.3.2. The designer must ensure that the lightning protection is in accordance with MIL-STD-188-124B and NFPA 780, Standard for the Installation of Lightning Protection Systems, latest issue.

3.4. ADDITIONAL MATERIALS The Contractor shall provide the following additional materials, required for facility startup, to the BCSO:

3.4.1. One(1) set of any and all special tools required to establish a cross connect and to change and/or maintain a terminal block.

3.4.2. Patch cords as defined in paragraph entitled "Patch Cables" in Part 2 of this standard.

3.4.3. Any materials or parts left over at the end of the project or turned over as part of the complete system shall be identified to the CO in the form of a complete inventory and provided to the BCSO with approval from the CO.

3.5. ADMINISTRATION AND LABELING

3.5.1. Labeling

3.5.1.1. All telecommunications systems labeling shall be done in accordance with LAFB standard labeling scheme provided as a technical exhibit to this specification (reference figure 1 of this standard) and TIA/EIA-606-A.

3.5.1.2. All outlets and patch panel positions must be labeled as to their function and with a unique identifier code.

3.5.1.3. All devices, outlet locations, and designations must also appear on the system drawings.

3.5.1.4. Labeling must be a minimum of 1/4-in. (6mm) high.

3.5.1.5. Handwritten labels must not be used for the final configuration.

3.5.2. Outlet/Connector Markings

3.5.2.1. As a minimum each jack shall be labeled as to its function and a unique number to identify cable link, as per LAFB standard labeling scheme.

3.5.2.2. Each communications outlet must have a unique identifying number in accordance with TIA/EIA 606-A.

3.5.2.3. In the TR, this unique identifying number must be associated with the position on the patch panel or cross-connect to which the outlet is connected.

3.5.2.4. Each horizontal cable must be labeled both at the outlet and patch panel or cross-connect position in the communications closet.

3.5.3. Telecommunications Patch Panel Labeling

3.5.3.1. Patch panel labeling must be done in accordance with TIA/EIA 606. Each position must be labeled with a unique designator corresponding to the outlet location.

3.5.3.2. FO port labeling must be done in accordance with TIA/EIA 606. The left or top connection should be labeled "A." The right or bottom connection should be labeled "B."

3.5.3.3. Color-coding in accordance with TIA/EIA-606-A may be added to the labeling.

3.5.4. Distribution System Labeling

3.5.4.1. The distribution system is described in TIA/EIA-606-A for pathways.

3.5.4.2. All transitions and changes in distribution system size and type must be labeled.

3.5.4.3. Each cabinet must be labeled at the top with a unique designation.

3.6. COMMUNICATION CABLING INSPECTION AND TESTING

3.6.1. Inspection

3.6.1.1. System inspection shall be provided through performance of pre-installation, in-progress and final inspections by the CO in conjunction with the BCSO (or authorized representative), at intervals provided below. Contractor is responsible to notify the CO and BCSO when installation has reached the below installation phases:

3.6.1.1.1. **(35 Percent)** will primarily consist of communication closet set-up, pathways and spaces, and cable support.

3.6.1.1.2. **(50 Percent)** will consist of cable handling and pulling techniques, adherence to industry standards, and code compliance.

3.6.1.1.3. **(75 Percent)** consists of termination techniques, review of testing procedures and test plan, and documentation.

3.6.1.1.3.1. Each item of installed equipment shall be checked to insure appropriate UL certification markings.

3.6.1.1.3.2. This inspection shall verify cabling terminations in TRs and at workstations adhere to color code for proper pin assignments and cabling connections are in compliance with ANSI/EIA/TIA standards.

3.6.1.1.3.3. Visually confirm proper cable category marking of cabling, outlets/connectors and patch cords.

3.6.1.1.3.4. There will be no 100% inspection until all areas up to the 75% inspection have been completed and the inspectors have reviewed testing documentation.

3.6.1.1.4. **(100 Percent)** Acceptance Inspection consists of documentation, final testing and test data, discrepancy review, operability testing, and final acceptance. This inspection shall verify that the equipment provided adheres to the installation requirements of this document. The interim inspection

will be conducted by a factory-certified representative and witnessed by a Government Representative Subject Matter Expert (SME) appointed by the BCSO and approved by the CO.

3.6.1.2. The Contractor shall notify the CO, in writing, of the estimated date the Contractor expects to be ready for the interim inspection, at least 20 working days before the requested inspection date.

3.6.1.3 The Contractor and/or the SME, shall perform in progress inspections, which shall include visual inspections of equipment condition, wiring, splicing, cabling, mounting and placement of equipment, miscellaneous hardware, and adherence to safety procedures. These inspections shall ensure compliance with the specified installation criteria.

3.6.1.4. The Contractor shall perform FO field inspection tests via attenuation measurements on factory reels and provide results along with manufacturer certification for factory reel tests to the CO. All FOCs shall be tested on the reels prior to installation. Remove failed cable reels from project site upon attenuation test failure.

3.6.1.4. Results of any inspection shall be provided to the CO and PM. If major or multiple deficiencies are discovered, a second interim inspection may be required before permitting the Contractor to continue with the system installation. The CO and/or the PM shall determine if an additional inspection is required, or if the Contractor will be allowed to proceed with the installation. In either case, re-inspection of the deficiencies noted during the interim inspection(s), will be part of the proof of performance test. The interim inspection shall not affect the Systems' completion date. The CO shall provide all test documents to the BCSO to become a part of the Systems record documentation.

3.6.1.6. The Contractor shall conduct a final inspection that encompasses all phases of the installed project. This inspection shall be conducted to verify all phases of the contract have been completed according to the specifications and that proper installation practices have been followed.

3.6.1.7. The Contractor shall provide, as part of the final inspection, a review of the as-installed telecommunications drawings (otherwise known as "as-built drawings") to the CO to be reviewed and approved by the BCSO upon completion of the installation. The SME and/or CO will participate in and witness the final inspection of the communication cabling system.

3.6.2 **CABLE TESTING** The Contractor shall perform the cable tests and provide complete detailed reports of all tests, for all cables and components, specified as follows and as herein:

3.6.2.1. **Acceptance Test** The Contractor shall schedule an acceptance test date and give the CO 30 days written notice prior to the date the acceptance test is expected to begin. The System shall be tested in the presence of a Government Representative and an OEM certified representative. The System shall be tested utilizing the approved test equipment to certify proof of performance and Life Safety compliance. The test shall verify that the total System meets the requirements of this specification. The notification of the acceptance test shall include the expected length (in time) of the test.

3.6.2.2. **Copper Backbone Verification Tests**

3.6.2.2.1. UTP Backbone copper cabling shall be tested for DC loop resistance, shorts, opens, intermittent faults, and polarity between conductors, and between conductors and shield if cable has overall shield.

3.6.2.2.2. Backbone wiring must be tested end-to-end, including termination devices, from terminal block to terminal block, in the respective TRs.

3.6.2.2.3. Test operation of shorting bars in connection blocks.

3.6.2.2.4. Test cables after termination but not cross-connected.

3.6.2.3. **Fiber Backbone Verification Tests**

3.6.2.3.1. For multimode FOC, perform optical fiber end-to-end attenuation tests at the 850 nm and 1300 nm windows in both directions, in accordance with TIA/EIA-568-B.3 and TIA-526-14-A using optical power meter and light source method for multimode FOC. All connectors shall be tested and the loss measured in dB and shall have a loss limit that complies with ANSI/TIA/EIA-526-14A.

3.6.2.3.2. For single-mode FOC, perform optical fiber end-to-end attenuation tests in accordance with TIA/EIA-568-B.3 and TIA-526-7 using optical power meter and light source method for single-mode FOC. All connectors shall be tested and the loss measured in dB and shall have a loss limit that complies with ANSI/TIA/EIA-526-7A.

3.6.2.4. **Performance Testing**

3.6.2.4.1. Perform the applicable Category 5e or greater tests, using the appropriately rated test set, for each outlet in accordance with ANSI/EIA/TIA-568-B.1 and ANSI/EIA/TIA-568-B.2.

3.6.2.4.1.1. Testing shall use the Permanent Link Test procedure of EIA ANSI/TIA/EIA-568-b.2. for all horizontal copper cables.

3.6.2.4.1.2. Additional testing shall be required for MUTOA and CP applications to provide the Channel length is not exceeded.

3.6.2.4.1.3. Test shall include the following: wire map, length, insertion loss, return loss, NEXT, PSNEXT, ELFEXT, PSELFEXT, propagation delay and delay skew.

3.6.2.4.1.4. All installed CAT 5e cable shall be tested for attenuation loss at 100 MHz and results reported in dB.

3.6.2.4.1.5. All installed Cat 6 cable shall be tested for attenuation loss at 250 MHz and results reported in dB.

3.6.2.4.2. FO Links: Perform end-to-end FOC link tests for each outlet in accordance with ANSI/EIA/TIA-568-B.3. All FO links shall be tested and the loss measured in dB/KM.

3.6.2.4.3. FO connectors must be visually inspected for scratches, pits or chips and must be re-terminated if any of these conditions exist. No cost shall be incurred by the government for the replacement of deficient cables.

3.6.2.5. After testing is completed, all circuits shall be restored to their pre-test state (i.e. reconnected, re-terminated, etc.)

3.6.2.6. The Contractor shall ensure that all telecommunications cable, installed as part of a project, be tested to the commercial standards for that cable system. All test results and certifications must be provided in a report upon completion of construction to the CO for review and approval by the BCSO responsible for system O&M.

3.6.2.7. Tests must be performed from both ends of each circuit. End to end testing is defined from the equipment end through the cross connect to the terminal end.

3.6.2.8 All "auto-test" results obtained from the cable tester shall be supplied in both hard copy and on disk to the CO and authorized representative.

3.6.2.9. All telecommunications cable tests shall be completed and all errors corrected before any other tests are started. Cables, which contain failed circuits, shall be replaced and retested to verify the standard is met.

3.6.2.10. **Grounding System** All grounds and bonds shall be tested for continuity according to EIA ANSI/TIA/EIA-607. Resistance to ground testing shall be accomplished on the ground electrode system in accordance with Technical Order 31.10.24, Part two, Chapter 6 and NFPA 70, sections 250-81, 250-83 and 250-86 and must be no less than five (5) Ohms. This standard shall apply to new and existing facilities. Test results shall be reported in hard copy format. The ground shall be labeled or tagged in accordance with EIA/TIA 606.

3.7. ACCEPTABILITY

3.7.1. **Tolerance Limits** The Contractor shall be responsible for immediate corrections to the communications cabling systems that shall bring it into full compliance with requirements that are revealed by these inspections. Following correction, a re-examination of previous non-compliant items will be conducted at the discretion of the CO.

3.7.2. **Additional Testing** After installation is complete, in addition to any other required testing, and at such times as the CO or his authorized representative directs, the Contractor shall conduct an operating test for approval. The installation shall be demonstrated to be in accordance with the requirements of this specification. Any defects revealed shall; be promptly corrected at no cost to the government and the tests re-conducted.

3.8. TEST REPORTS

3.8.1. The Contractor shall be responsible for recording and providing to the CO, all test data. Copies of all test results shall be submitted the CO or his authorized representative for review and remain the property of the Government for their records.

3.8.2 For all FOCs, power meter test results shall be provided hard copy and correspond to a labeled FOC.

3.8.3. All twisted pair copper cable shall be provided in hard copy format and as a disk copy output of the test results with the station ID assigned.

3.8.4. All test results shall be provided to the CO prior to Quality Assurance Inspection for acceptance of Premises Wire Distribution System installation.

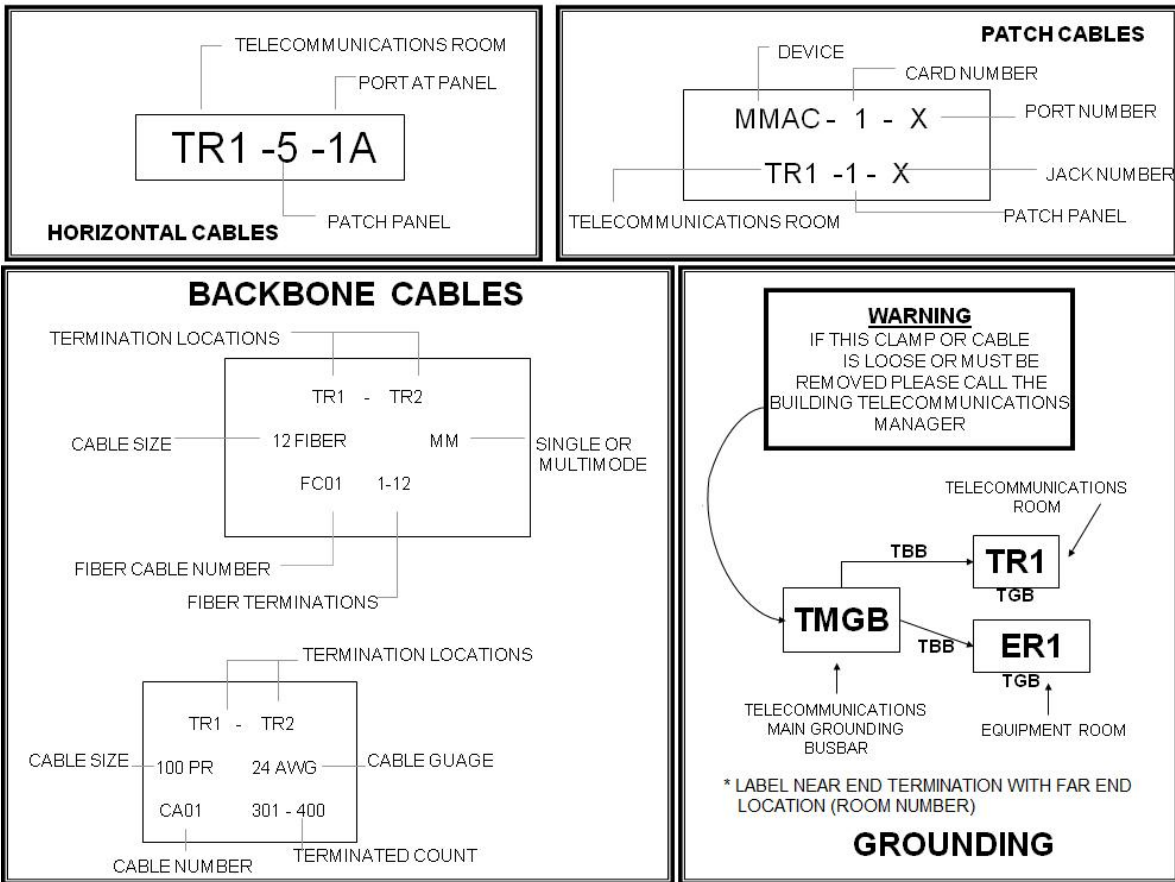
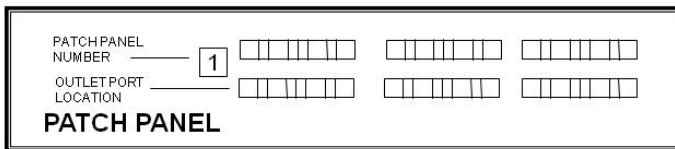
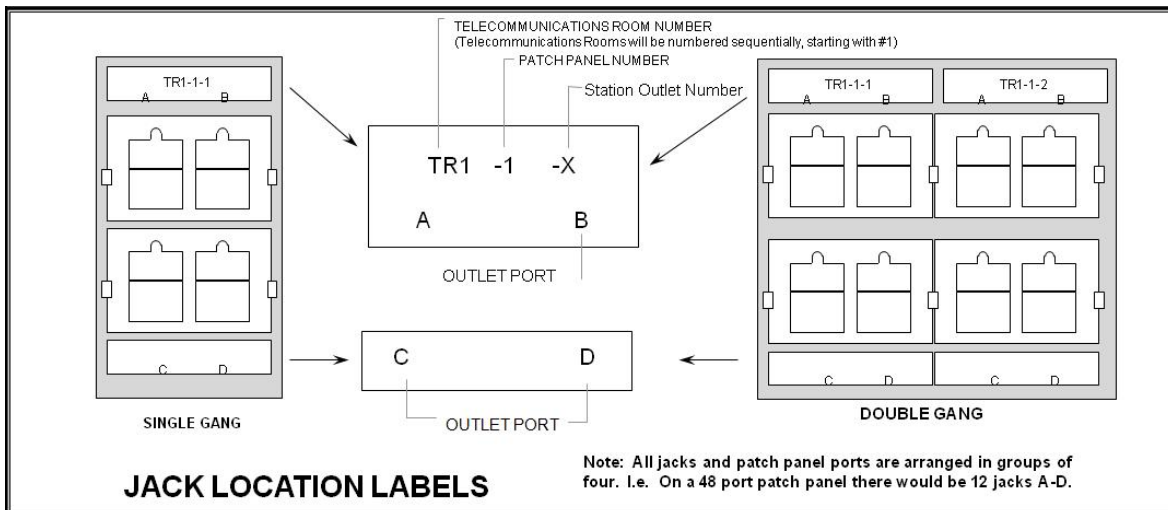

Figure 1 – LAFB Standard Labeling Scheme (sheet 1 of 2)



Jacks shall be arranged and labeled according to their location in a room. They shall be arranged clockwise in ascending order around the room while standing in the doorway looking into the room. Floor jack number arrangement should work in clockwise order, looking out the TR doorway. The 1CS labeling scheme adheres to the requirements outlined in the TIA/EIA 606 telecommunication standard.

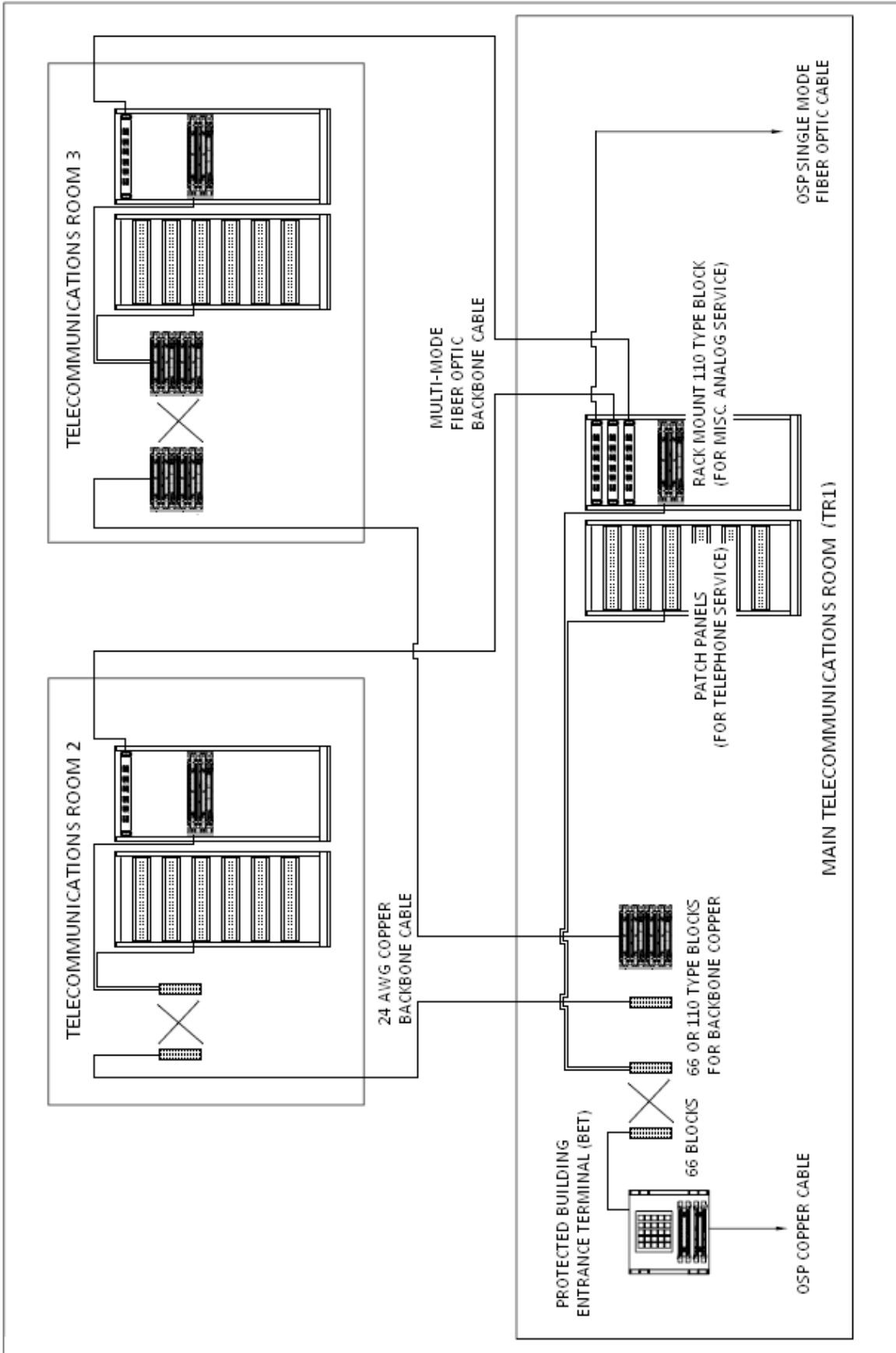

Figure 2 - Typical Telecommunications Room Entrance and Backbone Diagram

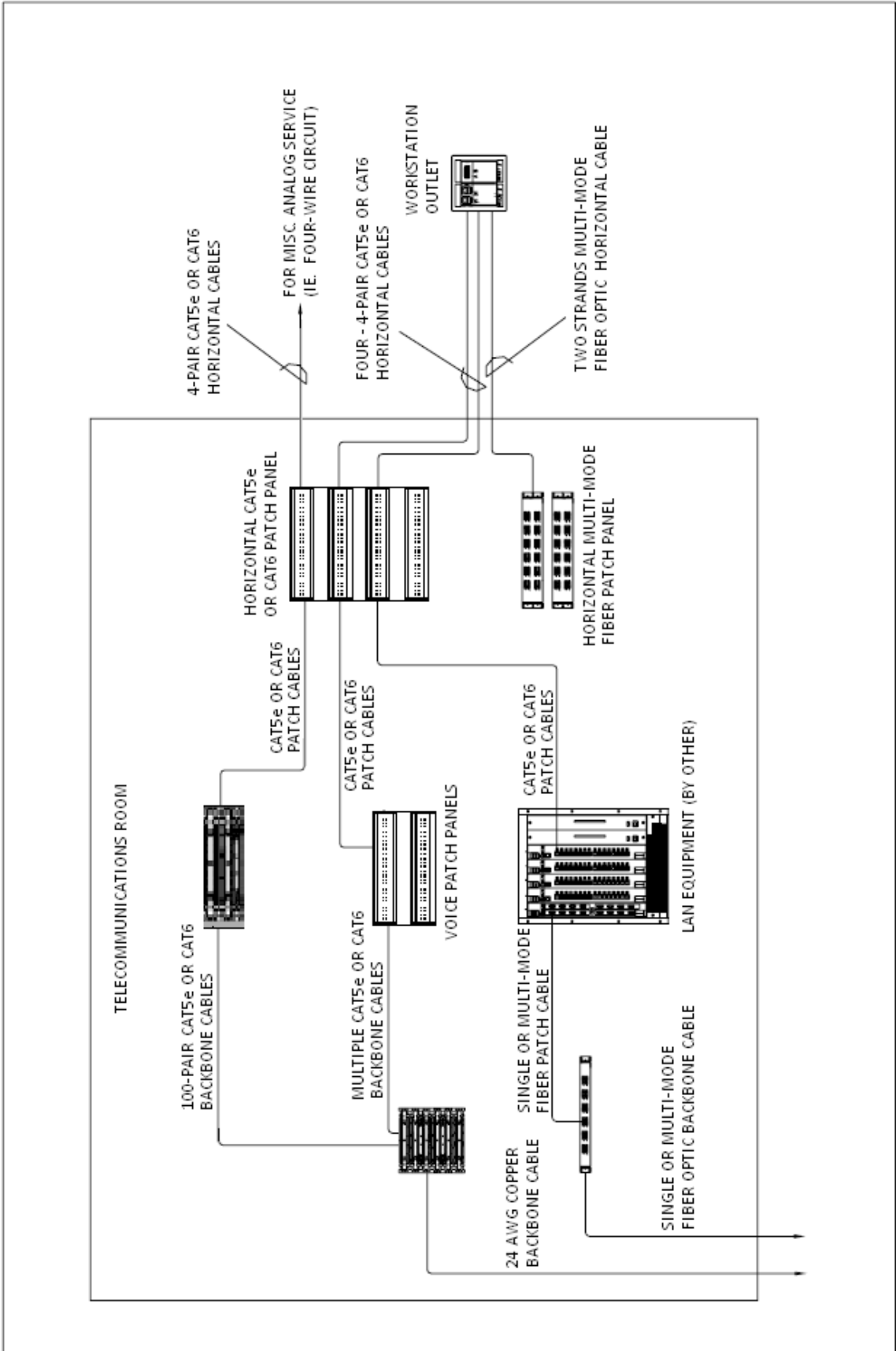

Figure 3 - Typical Telecommunications Room Horizontal Distribution Diagram

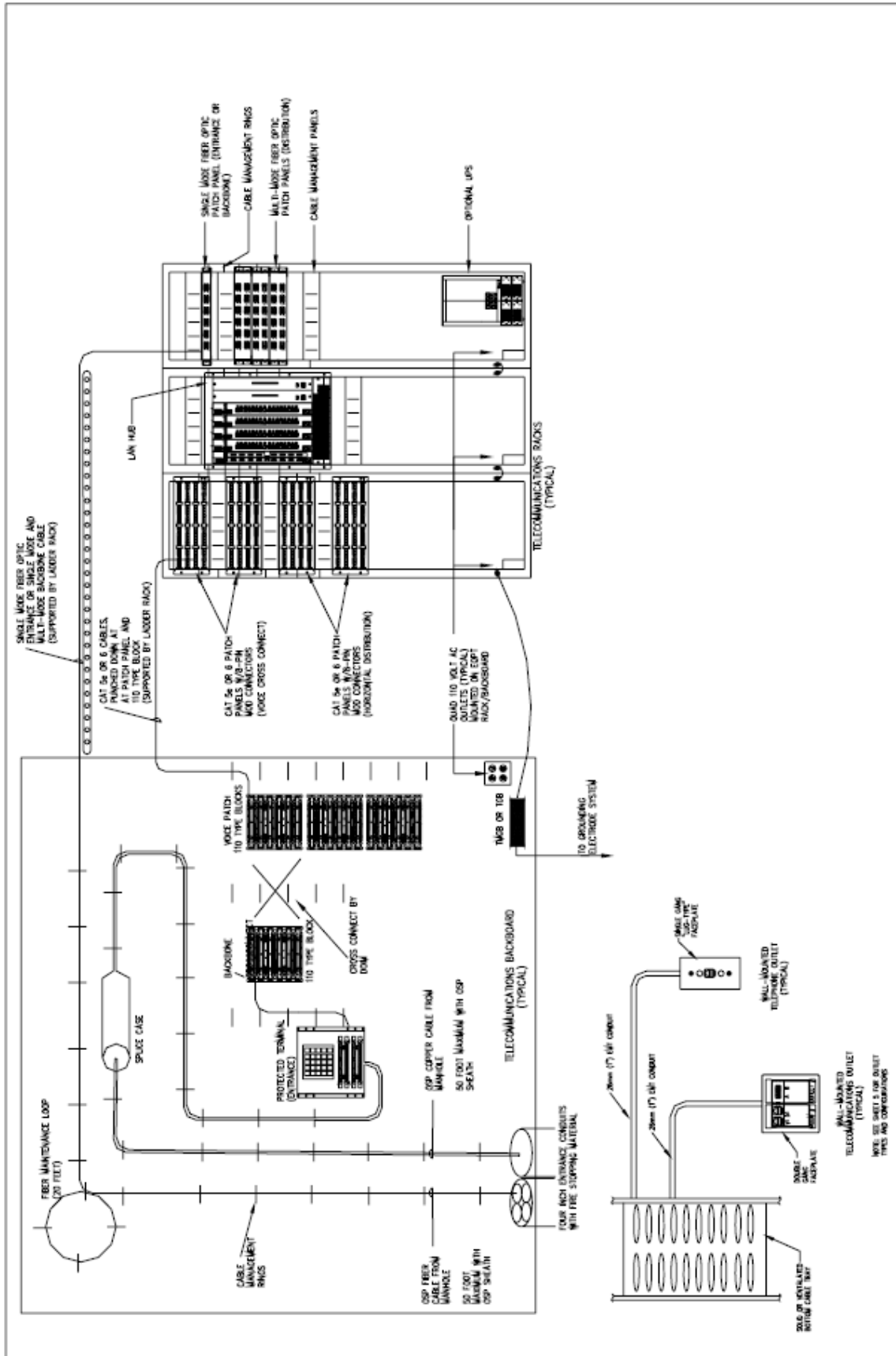
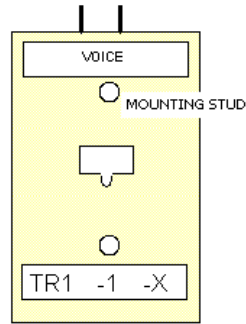

Figure 5 - Typical Telecommunications Room Standard Premise Wiring Distribution

3/4" C STUBBED ABOVE
CEILING - ONE (1) 4-PAIR,
24 AWG, UTP CAT5E CABLE



SINGLE OUTLET DETAIL TYPICAL

MARK (▼xx")

(NO SCALE)

xx" DENOTES HEIGHT OF OUTLET AFF

NOTE: Cabling for Single Outlets shall be terminated last on the last patch panel.

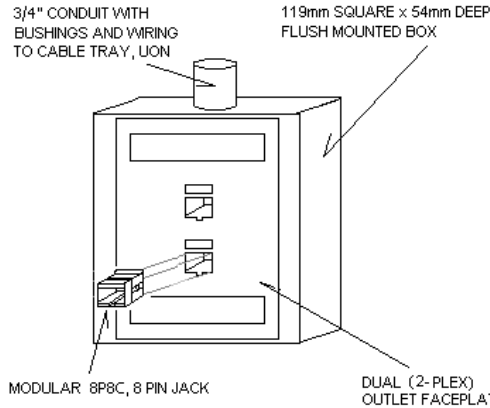

TYPICAL DUAL TELECOMMUNICATION OUTLET DETAIL MARK (▼)

NO SCALE

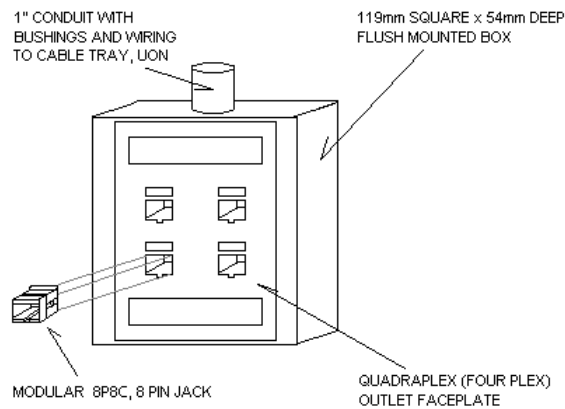

TYPICAL QUAD TELECOMMUNICATION OUTLET DETAIL MARK (▼)

NO SCALE

Figure 6 - Typical Telecommunications Outlet Type

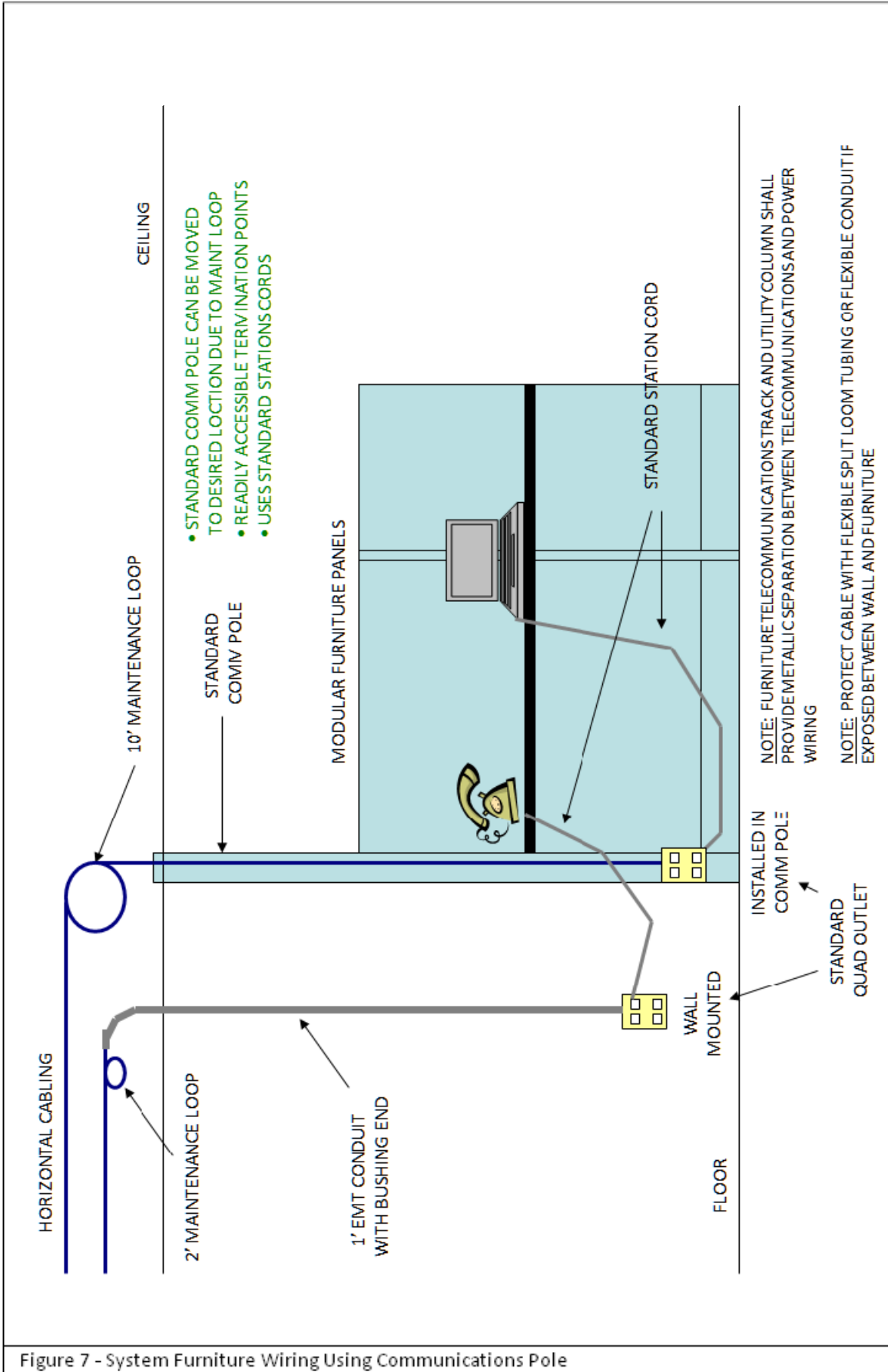

Figure 7 - System Furniture Wiring Using Communications Pole

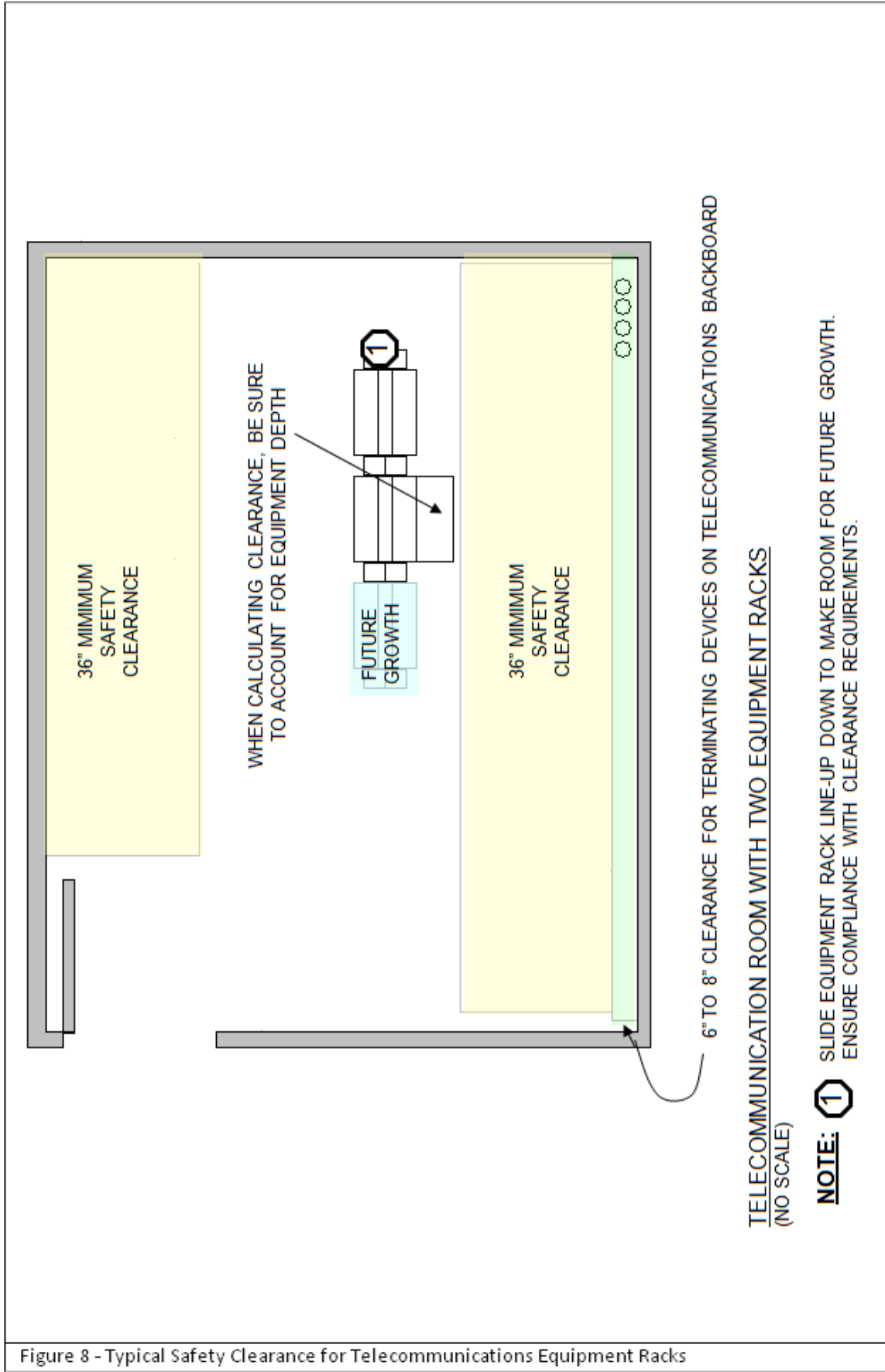

Figure 8 - Typical Safety Clearance for Telecommunications Equipment Racks

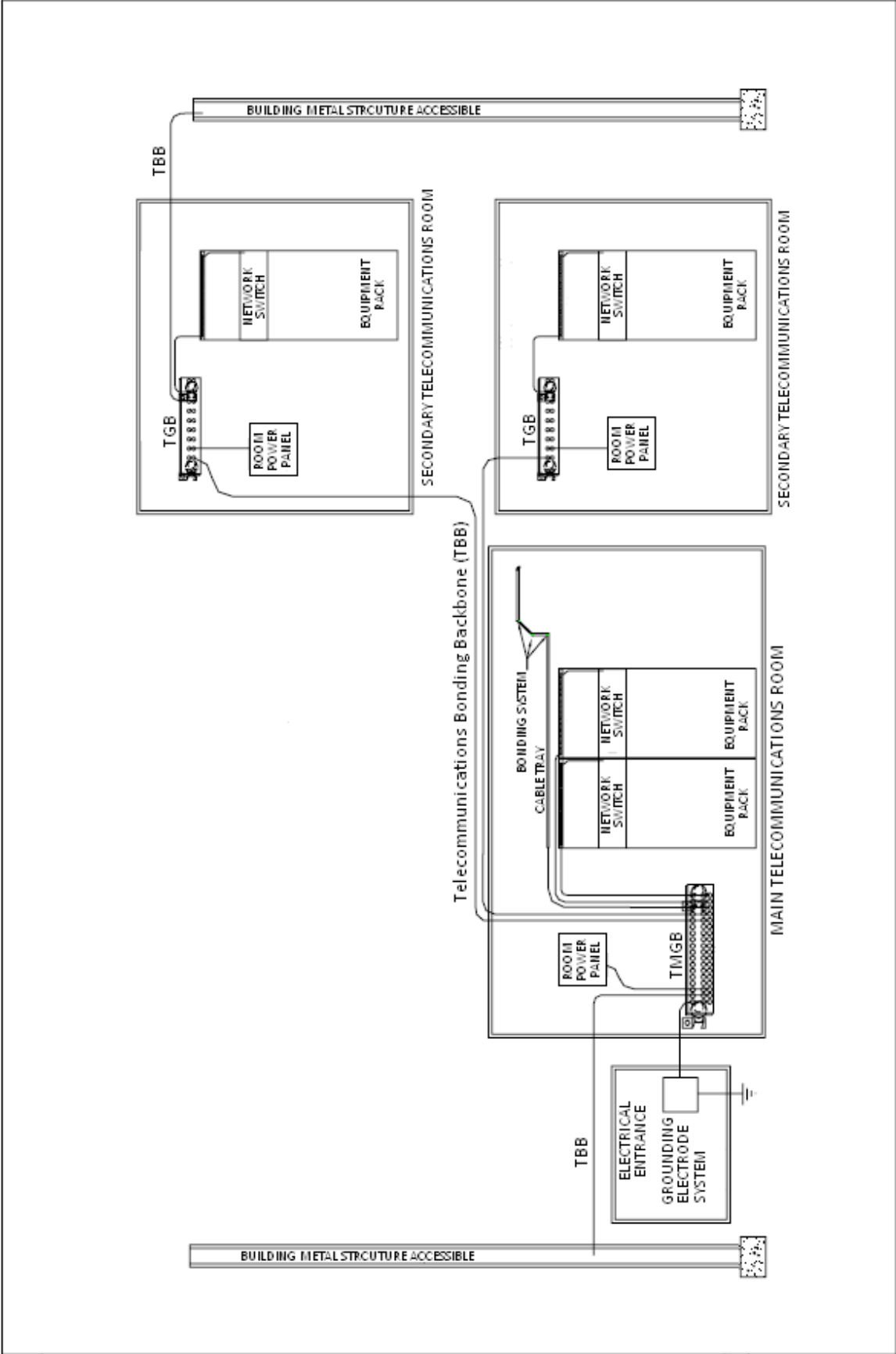

Figure 9 - Grounding and Bonding

BLANK PAGE

SECTION 31 00 00

EARTHWORK
08/08

PART 1 GENERAL

1.1 REFERENCES

The publications listed below form a part of this specification to the extent referenced. The publications are referred to within the text by the basic designation only.

AMERICAN ASSOCIATION OF STATE HIGHWAY AND TRANSPORTATION OFFICIALS
(AASHTO)

- AASHTO T 180 (2001; R 2004) Moisture-Density Relations of Soils Using a 4.54-kg (10-lb) Rammer and an 457-mm (18-in) Drop
- AASHTO T 224 (2001; R 2004) Correction for Coarse Particles in the Soil Compaction Test

AMERICAN WATER WORKS ASSOCIATION (AWWA)

- AWWA C600 (2005) Installation of Ductile-Iron Water Mains and Their Appurtenances

ASTM INTERNATIONAL (ASTM)

- ASTM C 136 (2006) Standard Test Method for Sieve Analysis of Fine and Coarse Aggregates
- ASTM C 33 (2007) Standard Specification for Concrete Aggregates
- ASTM D 1140 (2000; R 2006) Amount of Material in Soils Finer than the No. 200 (75-micrometer) Sieve
- ASTM D 1556 (2007) Density and Unit Weight of Soil in Place by the Sand-Cone Method
- ASTM D 1557 (2007) Standard Test Methods for Laboratory Compaction Characteristics of Soil Using Modified Effort (56,000 ft-lbf/ft³) (2700 kN-m/m³)
- ASTM D 2487 (2006e1) Soils for Engineering Purposes (Unified Soil Classification System)
- ASTM D 422 (1963; R 2007) Particle-Size Analysis of Soils
- ASTM D 4318 (2005) Liquid Limit, Plastic Limit, and Plasticity Index of Soils

REPAIR AIRFIELD RAMP LIGHTS

ASTM D 698 (2007e1) Laboratory Compaction Characteristics of Soil Using Standard Effort (12,400 ft-lbf/cu. ft. (600 kN-m/cu. m.))

U.S. ENVIRONMENTAL PROTECTION AGENCY (EPA)

EPA 600/4-79/020 (1983) Methods for Chemical Analysis of Water and Wastes

EPA SW-846.3-3 (1999, Third Edition, Update III-A) Test Methods for Evaluating Solid Waste: Physical/Chemical Methods

1.2 DEFINITIONS

1.2.1 Satisfactory Materials

Satisfactory materials comprise any materials classified by ASTM D 2487 as GW, GP, GM, GP-GM, GW-GM, GC, GP-GC, GM-GC, SW, SP, SM, SW-SM, SC, SW-SC, SP-SM, SP-SC, CL, ML, CL-ML, CH, MH. Satisfactory materials for grading comprise stones less than 8 inches, except for fill material for pavements which comprise stones less than 3 inches in any dimension.

1.2.2 Unsatisfactory Materials

Materials which do not comply with the requirements for satisfactory materials are unsatisfactory. Unsatisfactory materials also include man-made fills; trash; refuse; backfills from previous construction; and material classified as satisfactory which contains root and other organic matter or frozen material. Notify the Contracting Officer when encountering any contaminated materials.

1.2.3 Cohesionless and Cohesive Materials

Cohesionless materials include materials classified in ASTM D 2487 as GW, GP, SW, and SP. Cohesive materials include materials classified as GC, SC, ML, CL, MH, and CH. Materials classified as GM and SM will be identified as cohesionless only when the fines are nonplastic. Perform testing, required for classifying materials, in accordance with ASTM D 4318, ASTM C 136, ASTM D 422, and ASTM D 1140.

1.2.4 Degree of Compaction

Degree of compaction required, except as noted in the second sentence, is expressed as a percentage of the maximum density obtained by the test procedure presented in ASTM D 1557 abbreviated as a percent of laboratory maximum density. Since ASTM D 1557 applies only to soils that have 30 percent or less by weight of their particles retained on the 3/4 inch sieve, express the degree of compaction for material having more than 30 percent by weight of their particles retained on the 3/4 inch sieve as a percentage of the maximum density in accordance with AASHTO T 180 and corrected with AASHTO T 224. To maintain the same percentage of coarse material, use the "remove and replace" procedure as described in NOTE 8 of Paragraph 7.2 in AASHTO T 180.

1.2.5 Topsoil

Material suitable for topsoils is defined as: Natural, friable soil

REPAIR AIRFIELD RAMP LIGHTS

representative of productive, well-drained soils in the area, free of subsoil, stumps, rocks larger than one inch diameter, brush, weeds, toxic substances, and other material detrimental to plant growth. Amend topsoil pH range to obtain a pH of 5.5 to 7.

1.2.6 Unstable Material

Unstable material are too wet to properly support the utility pipe, conduit, or appurtenant structure.

1.2.7 Select Granular Material

Select granular material consist of materials classified as GW, GP, SW, or SP by ASTM D 2487 where indicated. The liquid limit of such material must not exceed 35 percent when tested in accordance with ASTM D 4318. The plasticity index must not be greater than 12 percent when tested in accordance with ASTM D 4318, and not more than 35 percent by weight may be finer than No. 200 sieve when tested in accordance with ASTM D 1140.

1.2.8 Initial Backfill Material

Initial backfill consists of select granular material or satisfactory materials free from rocks 2 inches or larger in any dimension or free from rocks of such size as recommended by the pipe manufacturer, whichever is smaller. When the pipe is coated or wrapped for corrosion protection, free the initial backfill material of stones larger than 1 inches in any dimension or as recommended by the pipe manufacturer, whichever is smaller.

1.2.9 Expansive Soils

Expansive soils are defined as soils that have a plasticity index equal to or greater than 12 when tested in accordance with ASTM D 4318.

1.3 SUBMITTALS

Submit the following in accordance with Section 01 11 00 SPECIAL CONDITIONS, Paragraph 1.2:

SD-06 Test Reports

Testing

Within 24 hours of conclusion of physical tests, 2 copies of test results, including calibration curves and results of calibration tests.

PART 2 PRODUCTS

2.1 REQUIREMENTS FOR OFFSITE SOILS

Test offsite soils brought in for use as backfill for Total Petroleum Hydrocarbons (TPH), Benzene, Toluene, Ethyl Benzene, and Xylene (BTEX) and full Toxicity Characteristic Leaching Procedure (TCLP) including ignitability, corrosivity and reactivity. Backfill shall contain a maximum of 100 parts per million (ppm) of total petroleum hydrocarbons (TPH) and a maximum of 10 ppm of the sum of Benzene, Toluene, Ethyl Benzene, and Xylene (BTEX) and shall pass the TCPL test. Determine TPH concentrations by using EPA 600/4-79/020 Method 418.1. Determine BTEX concentrations by using EPA SW-846.3-3 Method 5030/8020. Perform TCLP in accordance with

REPAIR AIRFIELD RAMP LIGHTS

EPA SW-846.3-3 Method 1311. Provide Borrow Site Testing for TPH, BTEX and TCLP from a composite sample of material from the borrow site, with at least one test from each borrow site. Do not bring material onsite until tests have been approved by the Contracting Officer.

2.2 BURIED WARNING AND IDENTIFICATION TAPE

Provide polyethylene plastic and metallic core or metallic-faced, acid- and alkali-resistant, polyethylene plastic warning tape manufactured specifically for warning and identification of buried utility lines. Provide tape on rolls, 3 inch minimum width, color coded as specified below for the intended utility with warning and identification imprinted in bold black letters continuously over the entire tape length. Warning and identification to read, "CAUTION, BURIED (intended service) LINE BELOW" or similar wording. Provide permanent color and printing, unaffected by moisture or soil.

Warning Tape Color Codes

Red:	Electric
Orange:	Telephone and Other Communications
Blue:	Water Systems
Green:	Sewer Systems

2.2.1 Warning Tape for Metallic Piping

Provide acid and alkali-resistant polyethylene plastic tape conforming to the width, color, and printing requirements specified above, with a minimum thickness of 0.003 inch and a minimum strength of 1500 psi lengthwise, and 1250 psi crosswise, with a maximum 350 percent elongation.

2.2.2 Detectable Warning Tape for Non-Metallic Piping

Provide polyethylene plastic tape conforming to the width, color, and printing requirements specified above, with a minimum thickness of 0.004 inch, and a minimum strength of 1500 psi lengthwise and 1250 psi crosswise. Manufacture tape with integral wires, foil backing, or other means of enabling detection by a metal detector when tape is buried up to 3 feet deep. Encase metallic element of the tape in a protective jacket or provide with other means of corrosion protection.

2.3 DETECTION WIRE FOR NON-METALLIC PIPING

Insulate a single strand, solid copper detection wire with a minimum of 12 AWG.

2.4 MATERIAL FOR RIP-RAP

2.4.1 Bedding Material

Provide bedding material consisting of sand, gravel, or crushed rock, well graded, with a maximum particle size of 2 inch. Compose material of tough, durable particles. Allow fines passing the No. 200 standard sieve with a plasticity index less than six.

2.4.2 Rock

Provide rock fragments sufficiently durable to ensure permanence in the

REPAIR AIRFIELD RAMP LIGHTS

structure and the environment in which it is to be used. Use rock fragments free from cracks, seams, and other defects that would increase the risk of deterioration from natural causes. Provide fragments sized so that no individual fragment exceeds a weight of 150 pounds and that no more than 10 percent of the mixture, by weight, consists of fragments weighing 2 pounds or less each. Provide rock with a minimum specific gravity of 2.50. Do not permit the inclusion of more than trace 1 percent quantities of dirt, sand, clay, and rock fines.

2.5 CAPILLARY WATER BARRIER

Provide capillary water barrier of clean, poorly graded crushed rock, crushed gravel, or uncrushed gravel placed beneath a building slab with or without a vapor barrier to cut off the capillary flow of pore water to the area immediately below. Conform to ASTM C 33 for fine aggregate grading with a maximum of 3 percent by weight passing ASTM D 1140, No. 200 sieve, or 1-1/2 inch and no more than 2 percent by weight passing the No. 4 size sieve or coarse aggregate Size 57, 67, or 77.

PART 3 EXECUTION

3.1 GENERAL EXCAVATION

Perform excavation of every type of material encountered within the limits of the project to the lines, grades, and elevations indicated and as specified. Perform the grading in accordance with the typical sections shown and the tolerances specified in paragraph FINISHING. Transport satisfactory excavated materials and place in fill or embankment within the limits of the work. Excavate unsatisfactory materials encountered within the limits of the work below grade and replace with satisfactory materials as directed. Include such excavated material and the satisfactory material ordered as replacement in excavation. Dispose surplus satisfactory excavated material not required for fill or embankment in areas approved for surplus material storage or designated waste areas. Dispose unsatisfactory excavated material in designated waste or spoil areas. During construction, perform excavation and fill in a manner and sequence that will provide proper drainage at all times. Excavate material required for fill or embankment in excess of that produced by excavation within the grading limits from the borrow areas indicated or from other approved areas selected by the Contractor as specified.

3.1.1 Ditches, Gutters, and Channel Changes

Finish excavation of ditches, gutters, and channel changes by cutting accurately to the cross sections, grades, and elevations shown on the drawings. Do not excavate ditches and gutters below grades shown. Backfill the excessive open ditch or gutter excavation with satisfactory, thoroughly compacted, material or with suitable stone or cobble to grades shown. Dispose excavated material as shown or as directed, except in no case allow material be deposited a maximum 4 feet from edge of a ditch. Maintain excavations free from detrimental quantities of leaves, brush, sticks, trash, and other debris until final acceptance of the work.

3.1.2 Dewatering

Control groundwater flowing toward or into excavations to prevent sloughing of excavation slopes and walls, boils, uplift and heave in the excavation and to eliminate interference with orderly progress of construction. Do not permit French drains, sumps, ditches or trenches within 3 feet of the

REPAIR AIRFIELD RAMP LIGHTS

foundation of any structure, except with specific written approval, and after specific contractual provisions for restoration of the foundation area have been made. Take control measures by the time the excavation reaches the water level in order to maintain the integrity of the in situ material. While the excavation is open, maintain the water level continuously, at least 2 feet below the working level.

3.1.3 Trench Excavation Requirements

Excavate the trench as recommended by the manufacturer of the pipe to be installed. Slope trench walls below the top of the pipe, or make vertical, and of such width as recommended in the manufacturer's printed installation manual. Provide vertical trench walls where no manufacturer's printed installation manual is available. Shore trench walls more than 4 feet high, cut back to a stable slope, or provide with equivalent means of protection for employees who may be exposed to moving ground or cave in. Shore vertical trench walls more than 4 feet high. Excavate trench walls which are cut back to at least the angle of repose of the soil. Give special attention to slopes which may be adversely affected by weather or moisture content. Do not exceed the trench width below the pipe top of 24 inches plus pipe outside diameter (O.D.) for pipes of less than 24 inch inside diameter, and do not exceed 36 inch plus pipe outside diameter for sizes larger than 24 inch inside diameter. Where recommended trench widths are exceeded, provide redesign, stronger pipe, or special installation procedures by the Contractor. The Contractor is responsible for the cost of redesign, stronger pipe, or special installation procedures without any additional cost to the Government.

3.1.3.1 Bottom Preparation

Grade the bottoms of trenches accurately to provide uniform bearing and support for the bottom quadrant of each section of the pipe. Excavate bell holes to the necessary size at each joint or coupling to eliminate point bearing. Remove stones as recommended by the pipe manufacturer to avoid point bearing.

3.1.3.2 Removal of Unstable Material

Where unstable material is encountered in the bottom of the trench, remove such material to the depth directed and replace it to the proper grade with select granular material as provided in paragraph BACKFILLING AND COMPACTION. When removal of unstable material is required due to the Contractor's fault or neglect in performing the work, the Contractor is responsible for excavating the resulting material and replacing it without additional cost to the Government.

3.1.4 Underground Utilities

The Contractor is responsible for movement of construction machinery and equipment over pipes and utilities during construction. Report damage to utility lines or subsurface construction immediately to the Contracting Officer.

3.2 SELECTION OF BORROW MATERIAL

Select borrow material to meet the requirements and conditions of the particular fill or embankment for which it is to be used. Obtain borrow material from the borrow areas within the limits of the project site, selected by the Contractor. Unless otherwise provided in the contract, the

REPAIR AIRFIELD RAMP LIGHTS

Contractor is responsible for obtaining the right to procure material, pay royalties and other charges involved, and bear the expense of developing the sources, including rights-of-way for hauling from the owners. Borrow material from approved sources on Government-controlled land may be obtained without payment of royalties. Unless specifically provided, do not obtain borrow within the limits of the project site without prior written approval. Consider necessary clearing, grubbing, and satisfactory drainage of borrow pits and the disposal of debris thereon related operations to the borrow excavation.

3.3 FINAL GRADE OF SURFACES TO SUPPORT CONCRETE

Do not excavate to final grade until just before concrete is to be placed. Protect shales from slaking and all surfaces from erosion resulting from ponding or water flow.

3.4 GROUND SURFACE PREPARATION

3.4.1 General Requirements

Remove and replace unsatisfactory material with satisfactory materials, as directed by the Contracting Officer, in surfaces to receive fill or in excavated areas. Scarify the surface to a depth of 6 inch before the fill is started. When subgrades are less than the specified density, break up the ground surface to a minimum depth of 6 inch, pulverizing, and compacting to the specified density. When the subgrade is part fill and part excavation or natural ground, scarify the excavated or natural ground portion to a depth of 12 inch and compact it as specified for the adjacent fill.

3.4.2 Frozen Material

Do not place material on surfaces that are muddy, frozen, or contain frost. Finish compaction by sheepsfoot rollers, pneumatic-tired rollers, steel-wheeled rollers, or other approved equipment well suited to the soil being compacted. Moisten material as necessary to provide the moisture content that will readily facilitate obtaining the specified compaction with the equipment used.

3.5 UTILIZATION OF EXCAVATED MATERIALS

Dispose unsatisfactory materials removing from excavations into designated waste disposal or spoil areas. Use satisfactory material removed from excavations, insofar as practicable, in the construction of fills, embankments, subgrades, shoulders, bedding (as backfill), and for similar purposes. Do not waste any satisfactory excavated material without specific written authorization. Dispose of satisfactory material, authorized to be wasted, in designated areas approved for surplus material storage or designated waste areas as directed. Clear and grub newly designated waste areas on Government-controlled land before disposal of waste material thereon. Stockpile and use coarse rock from excavations for constructing slopes or embankments adjacent to streams, or sides and bottoms of channels and for protecting against erosion. Do not dispose excavated material to obstruct the flow of any stream, endanger a partly finished structure, impair the efficiency or appearance of any structure, or be detrimental to the completed work in any way.

REPAIR AIRFIELD RAMP LIGHTS

3.6 BURIED TAPE AND DETECTION WIRE

3.6.1 Buried Warning and Identification Tape

Provide buried utility lines with utility identification tape. Bury tape 12 inch below finished grade; under pavements and slabs, bury tape 6 inch below top of subgrade.

3.6.2 Buried Detection Wire

Bury detection wire directly above non-metallic piping at a distance not to exceed 12 inch above the top of pipe. Extend the wire continuously and unbroken, from manhole to manhole. Terminate the ends of the wire inside the manholes at each end of the pipe, with a minimum of 3 feet of wire, coiled, remaining accessible in each manhole. Furnish insulated wire over it's entire length. Install wires at manholes between the top of the corbel and the frame, and extend up through the chimney seal between the frame and the chimney seal.

3.7 BACKFILLING AND COMPACTION

Place backfill adjacent to any and all types of structures, and compact to at least 90 percent laboratory maximum density for cohesive materials or 95 percent laboratory maximum density for cohesionless materials, to prevent wedging action or eccentric loading upon or against the structure. Prepare ground surface on which backfill is to be placed as specified in paragraph GROUND SURFACE PREPARATION. Provide compaction requirements for backfill materials in conformance with the applicable portions of paragraphs GROUND SURFACE PREPARATION. Finish compaction by sheepsfoot rollers, pneumatic-tired rollers, steel-wheeled rollers, vibratory compactors, or other approved equipment.

3.7.1 Trench Backfill

Backfill trenches to the grade shown. Do not backfill the trench until all specified tests are performed.

3.7.1.1 Replacement of Unyielding Material

Replace unyielding material removed from the bottom of the trench with select granular material or initial backfill material.

3.7.1.2 Replacement of Unstable Material

Replace unstable material removed from the bottom of the trench or excavation with select granular material placed in layers not exceeding 6 inch loose thickness.

3.7.1.3 Bedding and Initial Backfill

Provide bedding of the type and thickness shown. Place initial backfill material and compact it with approved tampers to a height of at least one foot above the utility pipe or conduit. Bring up the backfill evenly on both sides of the pipe for the full length of the pipe. Take care to ensure thorough compaction of the fill under the haunches of the pipe. Except as specified otherwise in the individual piping section, provide bedding for buried piping in accordance with AWWA C600, Type 4, except as specified herein. Compact backfill to top of pipe to 95 percent of ASTM D 698 maximum density. Provide plastic piping with bedding to spring

REPAIR AIRFIELD RAMP LIGHTS

line of pipe. Provide materials as follows:

- a. Class I: Angular, 0.25 to 1.5 inch, graded stone, including a number of fill materials that have regional significance such as coral, slag, cinders, crushed stone, and crushed shells.
- b. Class II: Coarse sands and gravels with maximum particle size of 1.5 inch, including various graded sands and gravels containing small percentages of fines, generally granular and noncohesive, either wet or dry. Soil Types GW, GP, SW, and SP are included in this class as specified in ASTM D 2487.

3.7.1.4 Final Backfill

Fill the remainder of the trench, except for special materials for roadways and airfields, with satisfactory material. Place backfill material and compact as follows:

- a. Roadways and Airfields: Place backfill up to the required elevation as specified. Do not permit water flooding or jetting methods of compaction.

3.7.2 Backfill for Appurtenances

After the utility structure has been constructed, place backfill in such a manner that the structure is not be damaged by the shock of falling earth. Deposit the backfill material, compact it as specified for final backfill, and bring up the backfill evenly on all sides of the structure to prevent eccentric loading and excessive stress.

3.8 SPECIAL REQUIREMENTS

Special requirements for both excavation and backfill relating to the specific utilities are as follows:

3.8.1 Electrical Distribution System

Provide a minimum cover of 24 inch from the finished grade to direct burial cable and conduit or duct line, unless otherwise indicated.

3.9 SUBGRADE PREPARATION

3.9.1 Construction

Shape subgrade to line, grade, and cross section, and compact as specified. Include plowing, disking, and any moistening or aerating required to obtain specified compaction for this operation. Remove soft or otherwise unsatisfactory material and replace with satisfactory excavated material or other approved material as directed. Excavate rock encountered in the cut section to a depth of 6 inch below finished grade for the subgrade. Bring up low areas resulting from removal of unsatisfactory material or excavation of rock to required grade with satisfactory materials, and shape the entire subgrade to line, grade, and cross section and compact as specified. Do not vary the elevation of the finish subgrade more than 0.05 foot from the established grade and cross section.

3.9.2 Compaction

Finish compaction by sheepsfoot rollers, pneumatic-tired rollers,

REPAIR AIRFIELD RAMP LIGHTS

steel-wheeled rollers, vibratory compactors, or other approved equipment. Except for paved areas and railroads, compact each layer of the embankment to at least 90 percent of laboratory maximum density.

3.9.2.1 Subgrade for Airfield Pavements

Compact top 24 inches below finished pavement or top 12 inches of subgrades, whichever is greater, to 100 percent of ASTM D 1557; compact fill and backfill material to 100 percent of ASTM D 1557.

3.10 FINISHING

Finish the surface of excavations, embankments, and subgrades to a smooth and compact surface in accordance with the lines, grades, and cross sections or elevations shown. Provide the degree of finish for graded areas within 0.1 foot of the grades and elevations indicated except that the degree of finish for subgrades specified in paragraph SUBGRADE PREPARATION. Finish gutters and ditches in a manner that will result in effective drainage. Repair graded or backfilled areas prior to acceptance of the work, and re-established grades to the required elevations and slopes.

3.10.1 Subgrade and Embankments

During construction, keep excavations shaped and drained. Do not disturb the finished subgrade by traffic or other operation. Protect and maintain the finished subgrade in a satisfactory condition until ballast, subbase, base, or pavement is placed. Do not permit the storage or stockpiling of materials on the finished subgrade. Do not lay subbase, base course, ballast, or pavement until the subgrade has been checked and approved, and in no case place subbase, base, surfacing, pavement, or ballast on a muddy, spongy, or frozen subgrade.

3.11 TESTING

Perform testing by a Corps validated commercial testing laboratory or the Contractor's validated testing facility. If the Contractor elects to establish testing facilities, do not permit work requiring testing until the Contractor's facilities have been inspected, Corps validated and approved by the Contracting Officer. Determine field in-place density in accordance with ASTM D 1556. When test results indicate, as determined by the Contracting Officer, that compaction is not as specified, remove the material, replace and recompact to meet specification requirements. Perform tests on recompacted areas to determine conformance with specification requirements. Appoint a registered professional civil engineer to certify inspections and test results. These certifications shall state that the tests and observations were performed by or under the direct supervision of the engineer and that the results are representative of the materials or conditions being certified by the tests. The following number of tests, if performed at the appropriate time, will be the minimum acceptable for each type operation.

3.11.1 In-Place Densities

- a. One test per 5000 square feet, or fraction thereof, of each lift of fill or backfill areas compacted by other than hand-operated machines.
- b. One test per 2500 square feet, or fraction thereof, of each lift of fill or backfill areas compacted by hand-operated machines.

REPAIR AIRFIELD RAMP LIGHTS

c. One test per 250 linear feet, or fraction thereof, of each lift of embankment or backfill for airfields.

3.11.2 Moisture Contents

In the stockpile, excavation, or borrow areas, perform a minimum of two tests per day per type of material or source of material being placed during stable weather conditions. During unstable weather, perform tests as dictated by local conditions and approved by the Contracting Officer.

3.11.3 Optimum Moisture and Laboratory Maximum Density

Perform tests for each type material or source of material including borrow material to determine the optimum moisture and laboratory maximum density values.

3.12 DISPOSITION OF SURPLUS MATERIAL

Provide surplus material or other soil material not required or suitable for filling or backfilling, and brush, refuse, stumps, roots, and timber as removed from Government property as directed by the Contracting Officer.

-- End of Section --

BLANK PAGE

SECTION 32 01 19

FIELD MOLDED SEALANTS FOR SEALING JOINTS IN RIGID PAVEMENTS
08/08

PART 1 GENERAL

1.1 REFERENCES

The publications listed below form a part of this specification to the extent referenced. The publications are referred to within the text by the basic designation only.

ASTM INTERNATIONAL (ASTM)

ASTM C 509 (2006) Elastomeric Cellular Preformed Gasket and Sealing Material

ASTM D 789 (2007) Determination of Relative Viscosity and Moisture Content of Polyamide (PA)

U.S. GENERAL SERVICES ADMINISTRATION (GSA)

FS SS-S-200 (Rev E; Am 2) Sealant, Joint, Two-Component, Jet-Blast-Resistant, Cold-Applied, for Portland Cement Concrete Pavement

1.2 SYSTEM DESCRIPTION

Machines, tools, and equipment used in the performance of the work required by this section shall be approved before the work is started maintained in satisfactory condition at all times.

1.2.1 Joint Cleaning Equipment

1.2.1.1 Concrete Saw

Provide a self-propelled power saw, with water-cooled diamond or abrasive saw blades, for cutting joints to the depths and widths specified or for refacing joints or cleaning sawed joints where sandblasting does not provide a clean joint.

1.2.1.2 Sandblasting Equipment

Include with the sandblasting equipment an air compressor, hose, and long-wearing venturi-type nozzle of proper size, shape and opening. The maximum nozzle opening should not exceed 1/4 inch. The air compressor shall be portable and capable of furnishing not less than 150 cfm and maintaining a line pressure of not less than 90 psi at the nozzle while in use. Demonstrate compressor capability, under job conditions, before approval. The compressor shall be equipped with traps that will maintain the compressed air free of oil and water. The nozzle shall have an adjustable guide that will hold the nozzle aligned with the joint approximately 1 inch above the pavement surface. Adjust the height, angle of inclination and the size of the nozzle as necessary to secure satisfactory results.

REPAIR AIRFIELD RAMP LIGHTS

1.2.1.3 Waterblasting Equipment

Include with the waterblasting equipment a trailer-mounted water tank, pumps, high-pressure hose, wand with safety release cutoff control, nozzle, and auxiliary water resupply equipment. Provide water tank and auxiliary resupply equipment of sufficient capacity to permit continuous operations. The nozzle shall have an adjustable guide that will hold the nozzle aligned with the joint approximately 1 inch above the pavement surface. Adjust the height, angle of inclination and the size of the nozzle as necessary to obtain satisfactory results. A pressure gauge mounted at the pump shall show at all times the pressure in psi at which the equipment is operating.

1.2.1.4 Hand Tools

Hand tools may be used, when approved, for removing defective sealant from a crack and repairing or cleaning the crack faces.

1.2.2 Sealing Equipment

1.2.2.1 Two-Component, Cold-Applied, Machine Mix Sealing Equipment

Provide equipment used for proportioning, mixing, and installing FS SS-S-200 Type M joint sealants designed to deliver two semifluid components through hoses to a portable mixer at a preset ratio of 1 to 1 by volume using pumps with an accuracy of plus or minus 5 percent for the quantity of each component. The reservoir for each component shall be equipped with mechanical agitation devices that will maintain the components in a uniform condition without entrapping air. Incorporate provisions to permit thermostatically controlled indirect heating of the components, when required. However, immediately prior to proportioning and mixing, the temperature of either component shall not exceed 90 degrees F. Provide screens near the top of each reservoir to remove any foreign particles or partially polymerized material that could clog fluid lines or otherwise cause misproportioning or improper mixing of the two components. Provide equipment capable of thoroughly mixing the two components through a range of application rates of 10 to 60 gallons per hour and through a range of application pressures from 50 to 1500 psi as required by material, climatic, or operating conditions. Design the mixer for the easy removal of the supply lines for cleaning and proportioning of the components. The mixing head shall accommodate nozzles of different types and sizes as may be required by various operations. The dimensions of the nozzle shall be such that the nozzle tip will extend into the joint to allow sealing from the bottom of the joint to the top. Maintain the initially approved equipment in good working condition, serviced in accordance with the supplier's instructions, and unaltered in any way without obtaining prior approval.

1.3 SUBMITTALS

Submit the following in accordance with Section 01 11 00 SPECIAL CONDITIONS, Paragraph 1.2:

SD-03 Product Data

Manufacturer's Recommendations; G

Printed copies of manufacturer's recommendations, 30 days prior to use on the project, where installation procedures, or any part

REPAIR AIRFIELD RAMP LIGHTS

thereof, are required to be in accordance with those recommendations. Installation of the material will not be allowed until the recommendations are received. Failure to furnish these recommendations can be cause for rejection of the material.

1.4 QUALITY ASSURANCE

1.4.1 Safety

Do not place joint sealant within 25 feet of any liquid oxygen (LOX) equipment, LOX storage, or LOX piping. Thoroughly clean joints in this area and leave them unsealed.

1.4.2 Test Requirements

Test the joint sealant and backup or separating material for conformance with the referenced applicable material specification. Perform testing of the materials in an approved independent laboratory and submit certified copies of the test reports for approval 7 days prior to the use of the materials at the job site. Samples will be retained by the Government for possible future testing should the materials appear defective during or after application. Conformance with the requirements of the laboratory tests specified will not constitute final acceptance of the materials. Final acceptance will be based on the performance of the in-place materials.

1.5 DELIVERY, STORAGE, AND HANDLING

Inspect materials delivered to the job site for defects, unload, and store them with a minimum of handling to avoid damage. Provide storage facilities at the job site for maintaining materials at the temperatures and conditions recommended by the manufacturer.

1.6 ENVIRONMENTAL REQUIREMENTS

The ambient air temperature and the pavement temperature within the joint wall shall be a minimum of 50 degrees F and rising at the time of application of the materials. Do not apply sealant if moisture is observed in the joint.

PART 2 PRODUCTS

2.1 SEALANTS

Materials for sealing cracks in the various paved areas indicated on the drawings shall be as follows:

Area	Sealing Material
_____	FS SS-S-200 Type M

2.2 PRIMERS

When primers are recommended by the manufacturer of the sealant, use them in accordance with the recommendation of the manufacturer.

REPAIR AIRFIELD RAMP LIGHTS

2.3 BACKUP MATERIALS

Provide backup material that is a compressible, nonshrinking, nonstaining, nonabsorbing material, nonreactive with the joint sealant. The material shall have a melting point at least 5 degrees F greater than the pouring temperature of the sealant being used when tested in accordance with ASTM D 789. The material shall have a water absorption of not more than 5 percent of the sample weight when tested in accordance with ASTM C 509. The backup material shall be 25 plus or minus 5 percent larger in diameter than the nominal width of the crack.

2.4 BOND BREAKING TAPES

Provide a bond breaking tape or separating material that is a flexible, nonshrinkable, nonabsorbing, nonstaining, and nonreacting adhesive-backed tape. The material shall have a melting point at least 5 degrees F greater than the pouring temperature of the sealant being used when tested in accordance with ASTM D 789. The bond breaker tape shall be approximately 1/8 inch wider than the nominal width of the joint and shall not bond to the joint sealant.

PART 3 EXECUTION

3.1 PREPARATION OF JOINTS

Immediately before the installation of the sealant, thoroughly clean the joints to remove all laitance, curing compound, filler, protrusions of hardened concrete, and old sealant from the sides and upper edges of the joint space to be sealed.

3.1.1 Existing Sealant Removal

Cut loose the in-place sealant from both joint faces as specified in paragraph SYSTEM DESCRIPTION. Depth shall be sufficient to accommodate any separating or backup material that is required to maintain the depth of new sealant to be installed. Prior to further cleaning operations, remove all loose old sealant remaining in the joint opening by blowing with compressed air. Hand tools may be required to remove sealant from random cracks. Chipping, spalling, or otherwise damaging the concrete will not be allowed.

3.1.2 Sandblasting

The newly exposed concrete joint faces and the pavement surfaces extending a minimum of 1/2 inch from the joint edges shall be sandblasted or waterblasted clean. Use a multiple-pass technique until the surfaces are free of dust, dirt, curing compound, filler, old sealant residue, or any foreign debris that might prevent the bonding of the sealant to the concrete. After final cleaning and immediately prior to sealing, blow out the joints with compressed air and leave them completely free of debris and water.

3.1.3 Back-Up Material

When the joint opening is of a greater depth than indicated for the sealant depth, plug or seal off the lower portion of the joint opening using a back-up material to prevent the entrance of the sealant below the specified depth. Take care to ensure that the backup material is placed at the specified depth and is not stretched or twisted during installation.

REPAIR AIRFIELD RAMP LIGHTS

3.1.4 Bond Breaking Tape

Where inserts or filler materials contain bitumen, or the depth of the joint opening does not allow for the use of a backup material, insert a bond breaker separating tape to prevent incompatibility with the filler materials and three-sided adhesion of the sealant. Securely bond the tape to the bottom of the joint opening so it will not float up into the new sealant.

3.1.5 Rate of Progress of Joint Preparation

Limit the stages of joint preparation, which include sandblasting, air pressure cleaning and placing of the back-up material to only that lineal footage that can be sealed during the same day.

3.2 PREPARATION OF SEALANT

3.2.1 Type M Sealants

Inspect the FS SS-S-200 Type M sealant components and containers prior to use. Reject any materials that contain water, hard caking of any separated constituents, nonreversible jell, or materials that are otherwise unsatisfactory. Settlement of constituents in a soft mass that can be readily and uniformly remixed in the field with simple tools will not be cause for rejection. Prior to transfer of the components from the shipping containers to the appropriate reservoir of the application equipment, thoroughly mix the materials to ensure homogeneity of the components and incorporation of all constituents at the time of transfer. When necessary for remixing prior to transfer to the application equipment reservoirs, warm the components to a temperature not to exceed 90 degrees F by placing the components in heated storage or by other approved methods but in no case shall the components be heated by direct flame, or in a single walled kettle, or a kettle without an oil bath.

3.3 INSTALLATION OF SEALANT

3.3.1 Time of Application

Seal joints immediately following final cleaning of the joint walls and following the placement of the separating or backup material. Open joints, that cannot be sealed under the conditions specified, or when rain interrupts sealing operations shall be recleaned and allowed to dry prior to installing the sealant.

3.3.2 Sealing Joints

Immediately preceding, but not more than 50 feet ahead of the joint sealing operations, perform a final cleaning with compressed air. Fill the joints from the bottom up to 1/8 inch plus or minus 1/16 inch below the pavement surface. Remove and discard excess or spilled sealant from the pavement by approved methods. Install the sealant in such a manner as to prevent the formation of voids and entrapped air. In no case shall gravity methods or pouring pots be used to install the sealant material. Traffic shall not be permitted over newly sealed pavement until authorized by the Contracting Officer. When a primer is recommended by the manufacturer, apply it evenly to the joint faces in accordance with the manufacturer's instructions. Check the joints frequently to ensure that the newly installed sealant is cured to a tack-free condition within the time specified.

REPAIR AIRFIELD RAMP LIGHTS

3.4 INSPECTION

3.4.1 Joint Cleaning

Inspect joints during the cleaning process to correct improper equipment and cleaning techniques that damage the concrete pavement in any manner. Cleaned joints will be approved prior to installation of the separating or back-up material and joint sealant.

3.4.2 Joint Sealant Application Equipment

Inspect the application equipment to ensure conformance to temperature requirements, proper proportioning and mixing (if two-component sealant) and proper installation. Evidences of bubbling, improper installation, failure to cure or set will be cause to suspend operations until causes of the deficiencies are determined and corrected.

3.4.3 Joint Sealant

Inspect the joint sealant for proper rate of cure and set, bonding to the joint walls, cohesive separation within the sealant, reversion to liquid, entrapped air and voids. Sealants exhibiting any of these deficiencies at any time prior to the final acceptance of the project shall be removed from the joint, wasted, and replaced as specified herein at no additional cost to the Government.

3.5 CLEAN-UP

Upon completion of the project, remove all unused materials from the site and leave the pavement in a clean condition.

-- End of Section --

REPAIR AIRFIELD RAMP LIGHTS

SECTION 32 01 26.71

GROOVING FOR AIRFIELD PAVEMENTS
08/08

PART 1 GENERAL

1.1 SYSTEM DESCRIPTION

1.1.1 Grooving Machine

Provide a grooving machine of a type equipped with diamond-saw cutting blades, and capable of making at least 18 inches in width of multiple parallel grooves in one pass of the machine. Thickness of the cutting blades shall be capable of making the required width and depth of grooves in one pass of the machine. The cutting head shall not contain a mixture of new and worn blades or blades of unequal wear or diameter. The wheels on the grooving machine shall be of a design that will not scar or spall the pavement. Provide the machine with devices to control depth of groove and alignment within the specified tolerances.

1.2 SUBMITTALS

Submit the following in accordance with Section 01 11 00 SPECIAL CONDITIONS, Paragraph 1.2:

SD-03 Product Data

Equipment

List of proposed equipment to be used in performance of construction work, including descriptive data.

1.3 ENVIRONMENTAL REQUIREMENTS

Grooving operations will not be permitted when freezing conditions prevent the immediate removal of debris and/or drainage of water from the grooved area.

PART 2 PRODUCTS (Not Applicable)

PART 3 EXECUTION

3.1 PREPARATION

3.1.1 Existing Pavements

Bumps, depressed areas, bad or faulted joints, and badly cracked and/or spalled areas in the pavement shall not be grooved until such areas are adequately repaired or replaced. If the existing pavement is not suitable because of its strength, an overlay, flexible or rigid, will be required.

3.1.2 New Pavements

Allow new asphalt concrete pavements to cure for a minimum of 30 days before grooving, to allow the material to become stable enough to prevent closing of the grooves under normal use. Permit new portland cement

REPAIR AIRFIELD RAMP LIGHTS

concrete pavements to cure for a minimum of 28 days before grooving.

3.2 GROOVING

3.2.1 Procedures

Cut grooves in the areas as indicated on the drawings. Begin the grooving at one side of the usable area and continue for the full width of the area. Take all reasonable precautions to prevent damage to or roughening of the pavement between grooves. Spalling along or tearing or raveling of the groove edges shall not be allowed. The grooves shall be 1/4 inch plus or minus 1/16 inch wide by 1/4 inch plus or minus 1/16 inch deep and 1-1/2 inches plus or minus 1/8 inch center to center spacing. The transverse alignment of the grooves shall not vary more than 3 inches plus or minus on a 75 foot length of grooving.

3.2.2 Clean-Up

Clean-up shall be continuous. Flush debris produced by the machine to the edge of the grooved area or pick it up as it forms. The dust coating remaining shall be flushed to the edge of the area if the resultant accumulation is not detrimental to the vegetation or storm drainage system. Accomplish all flushing operations in a manner to prevent erosion on the shoulders.

3.2.3 Repair of Damaged Pavement

Repair at the Contractor's expense any damage, which in the opinion of the Contracting Officer will be detrimental to aircraft tires, occurring to the pavement as a result of the grooving operations.

-- End of Section --

SECTION 32 13 13.03

AIRFIELDS AND HEAVY-DUTY CONCRETE PAVEMENT LESS THAN 10000 CUBIC YARDS
04/06

PART 1 GENERAL

1.1 REFERENCES

The publications listed below form a part of this specification to the extent referenced. The publications are referred to within the text by the basic designation only.

ACI INTERNATIONAL (ACI)

ACI 211.1	(1991; R 2002) Standard Practice for Selecting Proportions for Normal, Heavyweight, and Mass Concrete
ACI 214R	(2002) Recommended Practice for Evaluation of Strength Test Results of Concrete
ACI 301	(2005; Errata 2008) Specifications for Structural Concrete
ACI 305R	(1999; Errata 2006) Hot Weather Concreting
ACI 306R	(1988; R 2002) Cold Weather Concreting
ACI 325.9R	(1991; R 1997) Guide for Construction of Concrete Pavements and Bases

ASTM INTERNATIONAL (ASTM)

ASTM A 184/A 184M	(2006) Standard Specification for Fabricated Deformed Steel Bar Mats for Concrete Reinforcement
ASTM A 497/A 497M	(2007) Standard Specification for Steel Welded Wire Reinforcement, Deformed, for Concrete
ASTM A 615/A 615M	(2008b) Standard Specification for Deformed and Plain Carbon-Steel Bars for Concrete Reinforcement
ASTM A 775/A 775M	(2007b) Standard Specification for Epoxy-Coated Steel Reinforcing Bars
ASTM A 996/A 996M	(2006a) Standard Specification for Rail-Steel and Axle-Steel Deformed Bars or Concrete Reinforcement
ASTM C 1017/C 1017M	(2007) Standard Specification for Chemical Admixtures for Use in Producing Flowing Concrete

REPAIR AIRFIELD RAMP LIGHTS

ASTM C 1064/C 1064M	(2008) Standard Test Method for Temperature of Freshly Mixed Hydraulic-Cement Concrete
ASTM C 1077	(2008) Standard Practice for Laboratories Testing Concrete and Concrete Aggregates for Use in Construction and Criteria for Laboratory Evaluation
ASTM C 1116/C 1116M	(2008) Standard Specification for Fiber-Reinforced Concrete
ASTM C 117	(2004) Standard Test Method for Materials Finer than 75-um (No. 200) Sieve in Mineral Aggregates by Washing
ASTM C 123	(2004) Standard Test Method for Lightweight Particles in Aggregate
ASTM C 1260	(2007) Standard Test Method for Potential Alkali Reactivity of Aggregates (Mortar-Bar Method)
ASTM C 136	(2006) Standard Test Method for Sieve Analysis of Fine and Coarse Aggregates
ASTM C 142	(1997; R 2004) Standard Test Method for Clay Lumps and Friable Particles in Aggregates
ASTM C 143/C 143M	(2008) Standard Test Method for Slump of Hydraulic-Cement Concrete
ASTM C 150	(2007) Standard Specification for Portland Cement
ASTM C 172	(2008) Standard Practice for Sampling Freshly Mixed Concrete
ASTM C 174/C 174M	(2006) Standard Test Method for Measuring Thickness of Concrete Elements Using Drilled Concrete Cores
ASTM C 192/C 192M	(2007) Standard Practice for Making and Curing Concrete Test Specimens in the Laboratory
ASTM C 231	(2008c) Standard Test Method for Air Content of Freshly Mixed Concrete by the Pressure Method
ASTM C 260	(2006) Standard Specification for Air-Entraining Admixtures for Concrete
ASTM C 295	(2008) Petrographic Examination of Aggregates for Concrete
ASTM C 31/C 31M	(2008a) Standard Practice for Making and Curing Concrete Test Specimens in the Field

REPAIR AIRFIELD RAMP LIGHTS

ASTM C 33	(2007) Standard Specification for Concrete Aggregates
ASTM C 42/C 42M	(2004) Standard Test Method for Obtaining and Testing Drilled Cores and Sawed Beams of Concrete
ASTM C 494/C 494M	(2008a) Standard Specification for Chemical Admixtures for Concrete
ASTM C 618	(2008a) Standard Specification for Coal Fly Ash and Raw or Calcined Natural Pozzolan for Use in Concrete
ASTM C 78	(2008) Standard Test Method for Flexural Strength of Concrete (Using Simple Beam with Third-Point Loading)
ASTM C 88	(2005) Standard Test Method for Soundness of Aggregates by Use of Sodium Sulfate or Magnesium Sulfate
ASTM C 881/C 881M	(2002) Standard Specification for Epoxy-Resin-Base Bonding Systems for Concrete
ASTM C 94/C 94M	(2007) Standard Specification for Ready-Mixed Concrete
ASTM D 1751	(2004; R 2008) Standard Specification for Preformed Expansion Joint Filler for Concrete Paving and Structural Construction (Nonextruding and Resilient Bituminous Types)
ASTM D 1752	(2004a; R 2008) Standard Specification for Preformed Sponge Rubber Cork and Recycled PVC Expansion
ASTM D 4791	(2005e1) Flat Particles, Elongated Particles, or Flat and Elongated Particles in Coarse Aggregate
ASTM D 75	(2003) Standard Practice for Sampling Aggregates
U.S. ARMY CORPS OF ENGINEERS (USACE)	
COE CRD-C 114	(1997) Test Method for Soundness of Aggregates by Freezing and Thawing of Concrete Specimens
COE CRD-C 130	(2001) Standard Recommended Practice for Estimating Scratch Hardness of Coarse Aggregate Particles
COE CRD-C 171	(1994) Standard Test Method for Determining Percentage of Crushed

REPAIR AIRFIELD RAMP LIGHTS

Particles in Aggregate

COE CRD-C 300

(1990) Specifications for Membrane-Forming
Compounds for Curing Concrete

U.S. DEPARTMENT OF DEFENSE (DOD)

MIL-DTL-24441/20

(Rev A) Paint, Epoxy-Polyamide, Green
Primer, Formula 150, Type III

UFC 3-270-03

Concrete Crack and Partial-Depth Spall
Repair

1.2 SUBMITTALS

Submit the following in accordance with Section 01 11 00 SPECIAL
CONDITIONS, Paragraph 1.2:

SD-03 Product Data

Proposed Techniques; G

Placing and protection methods; paving sequence; jointing
pattern; data on curing equipment; demolition of existing
pavements; as specified.

SD-05 Design Data

Proportioning Studies; G

The results of the mixture proportioning studies must be signed
and stamped by the registered professional engineer having
technical responsibility for the mix design study and submitted at
least 30 days prior to commencing concrete placing operations.
The results must include a statement giving the maximum nominal
coarse aggregate size and the weights and volumes of each
ingredient proportioned on a one cubic yard basis. Base aggregate
quantities on the mass in a saturated surface dry condition.
Accompany the recommended mixture proportions by test results
demonstrating that the proportions selected will produce concrete
of the qualities indicated. The submittal must include:

- a. Coarse and fine aggregate gradations and plots.
- b. Combined aggregate gradation and coarseness/workability
plots.
- c. Coarse aggregate quality test results, including
deleterious materials.
- d. Fine aggregate quality test results.
- e. Mill certificates for cement, pozzolan, and GGBF slag.
- f. Certified test results for air entraining, water reducing,
retarding, non-chloride accelerating, and Lithium Nitrate
admixtures.
- g. Specified flexural strength, slump, and air content.
- h. Documentation for average CQC flexural strength increase.
- i. Recommended proportions/volumes for proposed mixture and
trial water-cementitious materials ratios.
- j. Individual beam and cylinder breaks.
- k. Flexural strength summaries and plots.
- l. Correlation ratios for acceptance testing and CQC testing.

REPAIR AIRFIELD RAMP LIGHTS

m. Historical record of test results, documenting production standard deviation (if available).

SD-06 Test Reports

Sampling and Testing; G

Certified copies of laboratory test reports and sources for cement, pozzolan, GGBF, aggregates, admixtures, curing compound, epoxy, and proprietary patching materials proposed for use on this project. All aggregate tests must have been performed no earlier than 6 months prior to contract award.

SD-07 Certificates

Contractor Quality Control Staff; G

American Concrete Institute certification for Contractor Quality Control staff.

Laboratory Accreditation; G

Accreditation of the commercial laboratory by an independent evaluation authority, indicating conformance to ASTM C 1077, including all applicable test procedures.

1.3 QUALIFICATIONS

1.3.1 Contractor Quality Control Staff

All Contractor Quality Control personnel assigned to concrete construction must be American Concrete Institute (ACI) certified in the following grade (or have written evidence acceptable to the Contracting Officer's representative of having completed similar qualification programs):

1. CQC personnel responsible for inspection of concrete paving operations: ACI Concrete Transportation Inspector.
2. Lead Foreman or Journeyman of the Concrete Placing, Finishing, and Curing Crews: ACI Concrete Flatwork Technician/Finisher.
3. Field Testing Technicians: ACI Concrete Field Testing Technician, Grade I.
4. Laboratory Testing Technicians: ACI Concrete Strength Testing Technician and Laboratory Testing Technician, Grade I or II.

1.3.2 Laboratory Accreditation

Laboratory and testing facilities must be provided by and at the expense of the Contractor. The laboratories performing the tests must be accredited in accordance with ASTM C 1077, including ASTM C 78 and ASTM C 1260. The accreditation must be current and must include the required and optional test methods, as specified throughout this SECTION. Provide onsite temperature-controlled concrete curing facilities.

REPAIR AIRFIELD RAMP LIGHTS

PART 2 PRODUCTS

2.1 CEMENTITIOUS MATERIALS

Ensure cementitious materials are portland cement or only portland cement in combination with natural pozzolan or fly ash and conforms to appropriate specifications listed below.

2.1.1 Portland Cement

Ensure portland cement conforms to ASTM C 150, Type I, II, or V, low alkali.

2.1.2 Pozzolan

2.1.2.1 Fly Ash

Ensure fly ash conforms to ASTM C 618, Class F, including the optional requirements for drying shrinkage, uniformity, and effectiveness in controlling Alkali-Silica reaction and has a loss on ignition not exceeding 6 percent. Ensure class F fly ash has a Calcium Oxide (CaO) content of less than 8 percent.

2.1.2.2 Raw or Calcined Natural Pozzolan

Ensure natural pozzolan is raw or calcined and conforms to ASTM C 618, Class N, including the optional requirements for drying shrinkage, uniformity, and effectiveness in controlling Alkali-Silica reaction and shall have a loss on ignition not exceeding 6 percent. Ensure class N pozzolan has a Calcium Oxide (CaO) content of less than 5 percent.

2.2 AGGREGATES

2.2.1 Aggregate Sources

2.2.1.1 Durability

Aggregate must have a satisfactory service record in freezing and thawing of at least 5 years successful service in three concrete paving projects. The service record must include a condition survey of the existing concrete and a review of the concrete-making materials, including coarse and fine aggregates, cement, and mineral admixtures. This review should consider the previous aggregate source and test results, cement mill certificate data, mineral admixture chemical and physical composition, and the mix design (cement factor and water-cementitious material ratio). Aggregate not having a satisfactory demonstrable service record must have a durability factor of 50 or more when subjected to freezing and thawing in concrete in accordance with COE CRD-C 114. Evaluate and test fine and coarse aggregates to be used in all concrete for durability in accordance with ASTM C 88. Results must not show more than 18 percent loss when subjected to 5 cycles using Magnesium Sulfate. If Sodium Sulfate is used, results must not show more than 12 percent loss when subjected to 5 cycles.

2.2.1.2 Alkali-Silica Reactivity

Evaluate and test fine and coarse aggregates to be used in all concrete for alkali-aggregate reactivity in accordance with ASTM C 1260. Test both coarse aggregate size groups if from different sources. Evaluate the fine and coarse aggregates separately and in combination, which matches the Contractor's proposed mix design proportioning, utilizing the modified

REPAIR AIRFIELD RAMP LIGHTS

version of ASTM C 1260. Test results of the combination must have a measured expansion equal to or less than 0.08 percent at 16 days after casting. Should the test data indicate an expansion of greater than 0.08 percent, reject the aggregate(s) or perform additional testing, using a modified version of ASTM C 1260 using one of the following options: Modify ASTM C 1260 as follows to included one of the following options:

- a. Utilize the Contractor's proposed low alkali portland cement and Class F fly ash or Class N pozzolan in combination with the proposed aggregate percentage for the test proportioning. Use Class F fly ash or Class N pozzolan in the range of 25 percent to 40 percent of the total cementitious material by mass. Determine the quantity that will meet all the requirements of these specifications and that will lower the expansion equal to or less than 0.08 percent at 16 days after casting.
- b. Utilize the Contractor's proposed low alkali portland cement and ground granulated blast furnace (GGBF) slag in combination with the proposed aggregate percentage for the test proportioning. Use GGBF slag in the range of 40 percent to 50 percent of the total cementitious material by mass. Determine the quantity that will meet all the requirements of these specifications and that will lower the expansion equal to or less than 0.08 percent at 16 days.

If any of the above options does not lower the expansion to less than 0.08 percent at 16 days after casting, reject the aggregate(s) and submit new aggregate sources for retesting. Submit the results of testing to the Contracting Officer for evaluation and acceptance.

2.2.1.3 Combined Aggregate Gradation

In addition to the grading requirements specified for coarse aggregate and for fine aggregate, the combined aggregate grading must meet the following requirement.

- a. The materials selected and the proportions used must be such that when the Coarseness Factor (CF) and the Workability Factor (WF) are plotted on a diagram as described in d. below, the point thus determined falls within the parallelogram described therein.
- b. Determine the Coarseness Factor (CF) from the following equation:
$$CF = (\text{cumulative percent retained on the } 3/8 \text{ in. sieve}) (100) / (\text{cumulative percent retained on the No. 8 sieve})$$
- c. The Workability Factor WF is defined as the cumulative percent passing the No. 8 sieve. However, adjust WF upwards only, by 2.5 percentage points for each 94 pounds of cementitious material per cubic yard greater than 564 pounds per cubic yard.
- d. Plot a diagram using a rectangular scale with WF on the Y-axis with units from 20 (bottom) to 45 (top), and with CF on the X-axis with units from 80 (left side) to 30 (right side). On this diagram, plot a parallelogram with corners at the following coordinates (CF-75, WF-28), (CF-75, WF-40), (CF-45, WF-32.5), and (CF-45, WF-44.5. If the point determined by the intersection of the computed CF and WF does not fall within the above parallelogram, change the grading of each size of aggregate used and the proportions selected as necessary.)

REPAIR AIRFIELD RAMP LIGHTS

e. Use a blending aggregate to meet the required combined grading. This blending aggregate must be batched separately. Compute the combined grading of all aggregates used, in the proportions selected, on the basis of cumulative percent retained on each sieve specified for fine and coarse aggregate.

2.2.2 Coarse Aggregate

2.2.2.1 Material Composition

Ensure coarse aggregate consists of crushed gravel, crushed stone, or a combination thereof. Ensure crushed gravel contains not less than 75 percent of crushed particles by mass in each sieve size, as determined by COE CRD-C 171. Reclaimed concrete pavement or granular base produced from required removal operations may not be used for aggregate.

2.2.2.2 Particle Shape Characteristics

Ensure particles of the coarse aggregate are generally spherical or cubical in shape. Ensure the quantity of flat and elongated particles in any size group does not exceed 20 percent by weight as determined by the Flat Particle Test and the Elongated Particle Test of ASTM D 4791. A flat particle is defined as one having a ratio of width to thickness greater than 3; an elongated particle is one having a ratio of length to width greater than 3.

2.2.2.3 Size and Grading

Ensure the nominal maximum size of the coarse aggregate is 1.5 inches. When the nominal maximum coarse size is greater than 1 inch, grade the coarse aggregates and furnish in two size groups meeting the individual grading requirements of ASTM C 33, Size No. 4 (1.5 to 0.75 inches) and Size No. 67 (0.75 inches to No. 4).

2.2.2.4 Deleterious Materials - Airfield Pavements

Ensure the amount of deleterious material in each size group of coarse aggregate does not exceed the limits shown in Table 5 below, determined in accordance with the test methods shown.

TABLE 5
LIMITS OF DELETERIOUS MATERIALS IN COARSE AGGREGATE
FOR AIRFIELD PAVEMENTS
Percentage by Mass

Materials ^(h)	Severe Weather	Moderate Weather	Negligible Weather
Clay lumps and friable particles (ASTM C 142)	0.2	0.2	1.0
Shale (a) (ASTM C 295)	0.1	0.2	--
Material finer than 0.075 mm (No. 200 sieve) (b) (ASTM C 117)	0.5	0.5	1.0

TABLE 5
LIMITS OF DELETERIOUS MATERIALS IN COARSE AGGREGATE
FOR AIRFIELD PAVEMENTS
Percentage by Mass

Materials ^(h)	Severe Weather	Moderate Weather	Negligible Weather
Lightweight particles (c) (ASTM C 123)	0.2	0.2	1.0
Clay ironstone (d) (ASTM C 295)	0.1	0.5	--
Chert and cherty stone (less than 2.40 Mg/cubic meter density SSD (2.40 Sp. Gr.)) (e) ASTM C 123 followed by ASTM C 295)	0.1	0.5	--
Claystone, mudstone, and siltstone (f) (ASTM C 295)	0.1	0.1	--
Shaly and argillaceous limestone (g) (ASTM C 295)	0.2	0.2	--
Other soft particles COE CRD-C 130	1.0	1.0	1.0
Total of all deleterious substances exclusive of material finer than 0.075 mm (No. 200 sieve)	1.0	2.0	3.0

a. Shale is defined as a fine-grained, thinly laminated or fissile sedimentary rock. It is commonly composed of clay or silt or both. It has been indurated by compaction or by cementation, but not so much as to have become slate.

b. Limit for material finer than 0.075 mm (No. 200 sieve) will be increased to 1.5 percent for crushed aggregates if the fine material consists of crusher dust that is essentially free from clay or shale.

c. The separation medium must have a density of 2.0 Mg/cubic meter (Sp. Gr. of 2.0). This limit does not apply to coarse aggregate manufactured from blast-furnace slag unless contamination is evident.

d. Clay ironstone is defined as an impure variety of iron carbonate, iron oxide, hydrous iron oxide, or combinations thereof, commonly mixed with clay, silt, or sand. It commonly occurs as dull, earthy particles, homogeneous concretionary masses, or hard-shell particles with soft interiors. Other names commonly used for clay ironstone are "chocolate bars" and limonite concretions.

e. Chert is defined as a rock composed of quartz, chalcedony or opal, or any mixture of these forms of silica. It is variable in color. The texture is so fine that the individual mineral grains are too small to

REPAIR AIRFIELD RAMP LIGHTS

be distinguished by the unaided eye. Its hardness is such that it scratches glass but is not scratched by a knife blade. It may contain impurities such as clay, carbonates, iron oxides, and other minerals. Cherty stone is defined as any type of rock (generally limestone) that contains chert as lenses and nodules, or irregular masses partially or completely replacing the original stone.

f. Claystone, mudstone, or siltstone, is defined as a massive fine-grained sedimentary rock that consists predominantly of indurated clay or silt without laminations or fissility. It may be indurated either by compaction or by cementation.

g. Shaly limestone is defined as limestone in which shale occurs as one or more thin beds or laminae. These laminae may be regular or very irregular and may be spaced from a few inches down to minute fractions of an inch. Argillaceous limestone is defined as a limestone in which clay minerals occur disseminated in the stone in the amount of 10 to 50 percent by weight of the rock; when these make up from 50 to 90 percent, the rock is known as calcareous (or dolomitic) shale (or claystone, mudstone, or siltstone).

h. Perform testing in accordance with the referenced test methods, except that the minimum sample size must be as specified in Paragraph: TESTING SEQUENCE DELETERIOUS MATERIALS-AIRFIELDS ONLY.

2.2.2.5 Testing Sequence Deleterious Materials -- Airfields Only

The Contractor will not be entitled to any extension of time or additional payment due to any delays caused by the testing, evaluation, or personnel requirements. Sample sizes must be in accordance with the referenced test methods. The size of the sample must be at least 200 pounds for the 3/4 to 1-1/2 inch size and 25 pounds for the No. 4 to 3/4 inch coarse aggregate and 10 pounds for the fine aggregate. Provide facilities for the ready procurement of representative test samples. The testing procedure on each sample of coarse aggregate for compliance with limits on deleterious materials is as follows:

Step 1: Test full sample for material finer than the No. 200 sieve. Discard material finer than the No. 200 sieve.

Step 2: Test remaining full sample for clay lumps and friable particles and remove.

Step 3: Test remaining full sample for lightweight particles (Sp.Gr.2.0) and remove.

Step 4. Test remaining full sample for chert and/or cherty stone with SSD density of less than 2.40 Mg/cubic meter (Sp. Gr. 2.40). Remove lightweight chert and/or cherty stone. Restore other materials less than 2.40 to the sample.

Step 5: Test remaining sample for clay-ironstone, shale, claystone, mudstone, siltstone, shaly and/or argillaceous limestone, and remove.

Step 6: Test approximately one-fifth of remaining full sample for other soft particles.

REPAIR AIRFIELD RAMP LIGHTS

2.2.3 Fine Aggregate

2.2.3.1 Composition

Ensure fine aggregate consists of natural sand, manufactured sand, or a combination of the two, and is composed of clean, hard, durable particles. Irrespective of the source from which it is obtained, all fine aggregate must be composed of clean, hard, durable particles meeting the requirements of ASTM C 33. Stockpile and batch each type of fine aggregate separately. Particles of the fine aggregate must be generally spherical or cubical in shape.

2.2.3.2 Grading

Ensure grading of the fine aggregate, as delivered to the mixer, conforms to the requirements of ASTM C 33.

2.2.3.3 Deleterious Material

The amount of deleterious material in the fine aggregate must not exceed the following limits by mass:

Material	Percentage by Mass
Clay lumps and friable particles ASTM C 142	1.0
Material finer than 0.075 mm (No. 200 sieve) ASTM C 117	3.0
Lightweight particles ASTM C 123 using a medium with a density of 2.0 Mg/cubic meter (Sp. Gr. of 2.0)	0.5
Total of all above	3.0

2.3 CHEMICAL ADMIXTURES

Chemical admixtures may only be used when the specific admixture type and manufacturer is the same material used in the mixture proportioning studies. The air-entraining admixture must conform to ASTM C 260. An accelerator conforming to ASTM C 494/C 494M, Type C, may be used only when specified in paragraph: SPECIFIED CONCRETE STRENGTH AND OTHER PROPERTIES and must not be used to reduce the amount of cementitious material used. Calcium chloride and admixtures containing calcium chloride must not be used. Ensure retarding or water-reducing admixture meets the requirements of ASTM C 494/C 494M, Type A, B, or D, except that the 6-month and 1-year compressive strength tests are waived. ASTM C 494/C 494M, Type F and G high range water reducing admixtures and ASTM C 1017/C 1017M admixtures must not be used.

2.4 MEMBRANE FORMING CURING COMPOUND

Membrane forming curing compound shall be a white pigmented compound conforming to COE CRD-C 300.

2.5 WATER

Water for mixing and curing must be fresh, clean, potable, and free of injurious amounts of oil, acid, salt, or alkali, except that non-potable water may be used if it meets the requirements of ASTM C 94/C 94M.

REPAIR AIRFIELD RAMP LIGHTS

2.6 JOINT MATERIALS

2.6.1 Expansion Joint Material

Expansion joint filler must be a preformed material conforming to ASTM D 1751 or ASTM D 1752 Type II OR III. Expansion joint filler must be 3/4 inch thick, and must be furnished in a single full depth piece.

2.6.2 Slip Joint Material

Slip joint material must be 1/4 inch thick expansion joint filler conforming to paragraph: EXPANSION JOINT MATERIAL.

2.7 REINFORCING

Ensure all reinforcement is free from loose, flaky rust, loose scale, oil, grease, mud, or other coatings that might reduce the bond with concrete. Removal of thin powdery rust and tight rust is not required. However, do not use reinforcing steel which is rusted to the extent that it does not conform to the required dimensions or mechanical properties.

2.7.1 Reinforcing Bars and Bar Mats

Ensure reinforcing bars conform to ASTM A 615/A 615M, billet-steel, Grade 60. Ensure bar mats conform to ASTM A 184/A 184M. The bar members must be billet steel.

2.7.2 Deformed Welded Wire Reinforcement

Ensure deformed Welded Wire Reinforcement conforms to ASTM A 497/A 497M, and is furnished in flat sheets.

2.7.2.1 Fiber Reinforcement

ASTM C 1116/C 1116M. Use 100 percent virgin nylon or polypropylene fibers, 23 micron diameter, 3/4 inch length with a minimum tensile strength of 70 ksi. Add fibers to the concrete mix at the batch plant at the rate of 1.5 lbs. per cubic yard.

2.8 DOWELS AND TIE BARS

2.8.1 Dowels

Dowels must be single piece bars fabricated or cut to length at the shop or mill before delivery to the site. Ensure dowels are free of loose, flaky rust and loose scale and are clean and straight. Dowels may be sheared to length provided that the deformation from true shape caused by shearing does not exceed 0.04 inch on the diameter of the dowel and does not extend more than 0.04 inch from the end of the dowel. Dowels must be plain (non-deformed) steel bars conforming to ASTM A 615/A 615M, Grade 40 or 60; ASTM A 996/A 996M, Grade 50 or 60. Ensure paint for dowels conforms to MIL-DTL-24441/20. As an alternate to paint, epoxy coatings conforming to ASTM A 775/A 775M may be used. Ensure grout retention rings are fully circular metal or plastic devices capable of supporting the dowel until the epoxy hardens.

REPAIR AIRFIELD RAMP LIGHTS

2.8.2 Dowel Bar Assemblies

Dowel bar assemblies must consist of a framework of metal bars or wires arranged to provide rigid support for the dowels throughout the paving operation, with a minimum of four continuous bars or wires extending along the joint line. ensure the dowels are welded to the assembly or held firmly by mechanical locking arrangements that will prevent them from rising, sliding out, or becoming distorted during paving operations.

2.8.3 Tie Bars

Ensure tie bars are deformed steel bars conforming to ASTM A 615/A 615M, or ASTM A 996/A 996M, Grade 60, and of the sizes and dimensions indicated. Deformed rail steel bars and high-strength billet or axle steel bars, Grade 50 or higher, must not be used for bars that are bent and straightened during construction.

2.9 EPOXY RESIN

Ensure all epoxy-resin materials are two-component materials conforming to the requirements of ASTM C 881/C 881M, Class as appropriate for each application temperature to be encountered, except that in addition, the materials must meet the following requirements:

- a. Material for use for embedding dowels and anchor bolts must be Type IV, Grade 3.
- b. Material for use as patching materials for complete filling of spalls and other voids and for use in preparing epoxy resin mortar must be Type III, Grade as approved.
- c. Material for use for injecting cracks must be Type IV, Grade 1.
- d. Material for bonding freshly mixed portland cement concrete or mortar or freshly mixed epoxy resin concrete or mortar to hardened concrete must be Type V, Grade as approved.

2.10 SPECIFIED CONCRETE STRENGTH AND OTHER PROPERTIES

2.10.1 Specified Flexural Strength

Specified flexural strength, R, for concrete is 650 psi at 28 days, as determined by tests made in accordance with ASTM C 78 of beams fabricated and cured in accordance with ASTM C 192/C 192M. Maximum allowable water-cementitious material ratio is 0.45. The water-cementitious material ratio will be the equivalent water-cement ratio as determined by conversion from the weight ratio of water to cement plus pozzolan. The concrete must be air-entrained with a total air content of 4 plus or minus 1.5 percentage points, at the point of placement. Determine air content in accordance with ASTM C 231. The maximum allowable slump of the concrete at the point of placement is 2 inches for pavement constructed with fixed forms. For slipformed pavement, at the start of the project, select a maximum allowable slump which will produce in-place pavement meeting the specified tolerances for control of edge slump. The selected slump is applicable to both pilot and fill-in lanes.

2.10.2 Concrete Temperature

The temperature of the concrete as delivered must conform to the

REPAIR AIRFIELD RAMP LIGHTS

requirements of paragraphs: PAVING IN HOT WEATHER and PAVING IN COLD WEATHER. Determine temperature of concrete in accordance with ASTM C 1064/C 1064M.

2.10.3 Concrete Strength for Final Acceptance

The strength of the concrete will be considered acceptable when the average equivalent 28-day flexural strengths for each lot are above the 'Specified Flexural Strength' as determined by correlation with 14-day compressive strength tests.

2.11 MIXTURE PROPORTIONS

2.11.1 Composition

Ensure concrete is composed of cementitious material, water, fine and coarse aggregates, and admixtures. Class F flyash or Class N Pozzolan, if used with non alkali reactive aggregates, must consist of not less than 15 percent of the cementitious material by mass and not more than 35 percent. If Class F fly ash or Class N pozzolan is required to mitigate potential alkali-aggregate reactivity, the percentage by mass, as determined from the modified ASTM C 1260 testing must be used in the mixture proportioning studies. Use Class F pozzolan or GGBF slag in all concrete mixtures. Class F pozzolan must consist of not less than 25 percent of cementitious materials by mass and not more than 40 percent. The total cementitious material content must be at least 517 lb./cu. yd.. Ensure admixtures consist of air entraining admixtures and may also include, as approved, accelerator, retarder and water-reducing admixture.

2.11.2 Proportioning Studies

Trial design batches, mixture proportioning studies, and testing requirements are the responsibility of the Contractor. Base trial mixtures having proportions, slumps, and air content suitable for the work on methodology described in ACI 211.1, modified as necessary to accommodate flexural strength.

2.11.2.1 Water-Cement Ratio

Use at least three different water-cement ratios, which will produce a range of strength encompassing that required on the project. The maximum allowable water-cement ratio required in paragraph: SPECIFIED FLEXURAL STRENGTH will be the equivalent water-cement ratio as determined by conversion from the mass ratio of water to cement plus pozzolan. In the case where GGBF slag is used, include the mass of the GGBF slag in the equations in ACI 211.1 for the term P, which is used to denote the mass of pozzolan. Proportion laboratory trial mixtures for maximum permitted slump and air content.

2.11.2.2 Trial Mixture Studies

Make separate sets of trial mixture studies for each combination of cementitious materials and each combination of admixtures proposed for use. Do not use a combination of either until proven by such studies, except that, if approved in writing and otherwise permitted by these specifications, an accelerator or a retarder may be used without separate trial mixture study. Design each mixture to promote easy and suitable concrete placement, consolidation and finishing, and to prevent segregation and excessive bleeding.

REPAIR AIRFIELD RAMP LIGHTS

2.11.2.3 Mixture Proportioning Procedure

The Contractor must perform the following:

- a. Fabricate, cure and test 6 test specimens per age for each mixture at 28 and 90 days.
- b. Using the average strength for each w/(c+p), plot the results from each mixture on separate graphs for w/(c+p) versus 28-day strength.
- c. From the graphs select a w/(c+p) which will produce a mixture giving a 28-day strength equal to the required strength.

2.11.3 Average Strength Required for Mixtures

In order to ensure meeting, during production, the strength requirements specified, the mixture proportions selected must produce a required average strength, f'_{cr} , exceeding the specified strength, f'_c , in accordance with procedures in Chapter 3 of ACI 301, "Proportioning."

PART 3 EXECUTION

3.1 PREPARATION FOR PAVING

Before commencing paving, perform the following:

Ensure forms are in place, cleaned, coated, and adequately supported.

Ensure equipment for spreading, consolidating, screeding, finishing, and texturing concrete is at the paving site, clean and in proper working order.

Ensure all equipment and material for curing and for protecting concrete from weather or mechanical damage is at the paving site, in proper working condition, and in sufficient amount for the entire placement.

3.1.1 Weather Prevention

When windy conditions during paving appear probable, equipment and material must be at the paving site to provide windbreaks, shading, fogging, or other action to prevent plastic shrinkage cracking or other damaging drying of the concrete.

3.2 CONDITIONING OF UNDERLYING MATERIAL

Underlying material and base course, upon which concrete is to be placed must be clean, damp, and free from debris, waste concrete or cement, frost, ice, and standing or running water. After the underlying material has been prepared for concrete placement, no equipment is permitted thereon.

3.3 WEATHER LIMITATIONS

3.3.1 Placement and Protection During Inclement Weather

Follow practice found in ACI 325.9R, Chapter 10.

REPAIR AIRFIELD RAMP LIGHTS

3.3.2 Paving in Hot Weather

The temperature of concrete must not exceed 90 degrees F. Ensure steel forms, dowels and reinforcing is cooled prior to concrete placement when steel temperatures are greater than 120 degrees F. Follow practices found in ACI 305R.

3.3.3 Prevention of Plastic Shrinkage Cracking

During weather with low humidity, and particularly with high temperature and appreciable wind, develop and institute measures to prevent plastic shrinkage cracks from developing. If plastic shrinkage cracking occurs, halt further placement of concrete until protective measures are in place to prevent further cracking. Periods of high potential for plastic shrinkage cracking can be anticipated by use of Fig. 2.1.5 of ACI 305R.

3.3.4 Paving in Cold Weather

Ensure cold weather paving conforms to ACI 306R. Do not begin placement of concrete unless the ambient temperature is at least 35 degrees F and rising. Thereafter, halt placement of concrete whenever the ambient temperature drops below 40 degrees F. When the ambient temperature is less than 50 degrees F, ensure the temperature of the concrete when placed is not less than 50 degrees F nor more than 75 degrees F. Ensure materials entering the mixer are free from ice, snow, and frozen lumps. Do not incorporate salt, chemicals or other materials in the concrete to prevent freezing. If allowed under paragraph: MIXTURE PROPORTIONS, an accelerating admixture may be used when the ambient temperature is below 50 degrees F. Provide covering and other means for maintaining the concrete at a temperature of at least 50 degrees F for not less than 72 hours after placing, and at a temperature above freezing for the remainder of the curing period.

3.4 CONCRETE PRODUCTION

Ensure batching, mixing, and transporting conforms to ASTM C 94/C 94M. A batch ticket from the operator of the batching plant must accompany every load of concrete delivered to the paving site. Ensure tickets are on approved forms and show at least the mass, or volume, of all ingredients in each batch delivered, the water meter and revolution meter reading on truck mixers and the time of day. Deliver tickets to the placing foreman who must keep them on file and deliver them to the Government weekly.

3.5 PAVING

3.5.1 General Requirements

Construct pavement with paving and finishing equipment utilizing rigid fixed forms.

3.5.2 Consolidation

Consolidate concrete as specified or by hand-operated vibrators. Insert the vibrators into the concrete to a depth that will provide the best full-depth consolidation but not closer to the underlying material than 2 inches.

REPAIR AIRFIELD RAMP LIGHTS

3.5.3 Fixed Form Paving

Ensure paving equipment for fixed-form paving and its operation conforms to the requirements of paragraph EQUIPMENT, all requirements specified above under paragraph PAVING and as specified herein.

3.5.3 Forms for Fixed Form Paving

- a. Ensure straight forms are made of steel and furnished in sections not less than 10 feet in length. Use flexible or curved forms of proper radius for curves of 100-foot radius or less. Ensure wood forms for curves and fillets are made of well-seasoned, surfaced plank or plywood, straight, and free from warp or bend. Ensure wood forms are adequate in strength and rigidly braced. Forms must have a depth equal to the pavement thickness at the edge. Maximum vertical deviation of top of any side form, including joints, must not vary from a true plane more than 1/8 inch in 10 feet, and the upstanding leg shall not vary more than 1/4 inch.
- b. Tightly lock form sections and ensure they are free from play or movement in any direction. Provide forms with adequate devices for secure settings so that when in place they will withstand, without visible spring or settlement, the impact and vibration of the consolidating and finishing equipment.
- c. Set forms for full bearing on foundation for entire length and width and in alignment with edge of finished pavement. Support forms during entire operation of placing, compaction, and finishing so that forms will not deviate vertically more than 0.01 foot from required grade and elevations indicated. Do not place concrete until setting of forms has been checked and approved by the CQC team.
- d. For overlay pavements and for other locations where forms must be set on existing pavements, hold forms securely in place with stakes or by other approved methods. Holes in existing pavements for form stakes must be carefully drilled by methods which will not crack or spall the existing pavement. After use, fill the holes flush with the surrounding surface using approved material, prior to overlying materials being placed. Immediately discontinue any method which does not hold the form securely or which damages the existing pavement. Prior to setting forms for paving operations, demonstrate the proposed form setting procedures at an approved location and do not proceed further until the proposed method is approved by the Contracting Officer.

3.5.4 Placing Reinforcing Steel

Position the reinforcement on suitable chairs securely fastened to the subgrade prior to concrete placement. Vibrate concrete after the steel has been placed. Regardless of placement procedure, ensure the reinforcing steel is free from coatings which could impair bond between the steel and concrete, and indicate laps in the reinforcement as indicated. In lieu of the above, automatic reinforcement depressing attachments may be used to position the reinforcement provided the entire operation is approved by the Contracting Officer. Regardless of the equipment or procedures used for installing reinforcement, ensure that the entire depth of concrete is adequately consolidated.

REPAIR AIRFIELD RAMP LIGHTS

3.5.5 Placing Dowels and Tie Bars

The method used in installing and holding dowels in position must ensure that the error in alignment of any dowel from its required horizontal and vertical alignment after the pavement has been completed will not be greater than 1/8 in. per ft. Except as otherwise specified below, horizontal spacing of dowels must be within a tolerance of plus or minus 5/8 inch. Check the horizontal alignment with a framing square. Do not place dowels or and tie bars closer than 0.6 times the dowel bar or tie bar length to the planned joint line. If the last regularly spaced dowel or tie bar is closer than that dimension, it must be moved away from the joint to a location 0.6 time the dowel bar length. Install dowels as specified in the following subparagraphs.

3.5.5.1 Contraction Joints

Hold dowels and tie bars in longitudinal and transverse contraction joints within the paving lane securely in place, as indicated, by means of rigid metal frames or basket assemblies of an approved type. Hold the basket assemblies securely in the proper location by means of suitable pins or anchors.

3.5.5.2 Construction Joints-Fixed Form Paving

Install dowels and tie bars using the bonded-in-place method. Do not install by removing and replacing in preformed holes. Prepare dowels and tie bars and place across joints where indicated, correctly aligned, and securely held in the proper horizontal and vertical position during placing and finishing operations, by means of devices fastened to the forms.

3.5.5.3 Dowels Installed In Hardened Concrete

Install dowels in hardened concrete by bonding the dowels into holes drilled into the hardened concrete. Drill holes approximately 1/8 inch greater in diameter than the dowels into the hardened concrete. Repair any damage to the concrete face during drilling as directed. Bond dowels in the drilled holes using epoxy resin. Inject epoxy resin at the back of the hole before installing the dowel and extruded to the collar during insertion of the dowel so as to completely fill the void around the dowel. Do not apply by buttering the dowel. Hold the dowels in alignment at the collar of the hole, after insertion and before the grout hardens, by means of a suitable metal or plastic grout retention ring fitted around the dowel.

3.5.5.4 Lubricating Dowel Bars

Wipe clean the portion of each dowel intended to move within the concrete or expansion cap and coat with a thin, even film of lubricating oil before the concrete is placed.

3.6 FINISHING

Finishing operations shall be a continuing part of placing operations starting immediately behind the strike-off of the paver. Provide initial finishing by the transverse screed or extrusion plate. The sequence of operations are transverse finishing, longitudinal machine floating if used, straightedge finishing, texturing, and then edging of joints. Finish by the machine method. Use the hand method only on isolated areas of odd slab widths or shapes and in the event of a breakdown of the mechanical

REPAIR AIRFIELD RAMP LIGHTS

finishing equipment. Keep supplemental hand finishing for machine finished pavement to an absolute minimum. Make every effort to prevent bringing excess paste to the surface and halt any operations which produce more than 1/8 inch of paste (mortar, water, laitance, etc.) over the top layer of coarse aggregate immediately and the equipment, mixture, or procedures modified as necessary.

3.6.1 Machine Finishing With Fixed Forms

Use a machine designed to ride the forms and operate to screed and consolidate the concrete. Replace machines that cause displacement of the forms. The machine shall make only one pass over each area of pavement. If the equipment and procedures do not produce a surface of uniform texture, true to grade, in one pass, immediately stop the operation and the equipment, mixture, and procedures adjusted as necessary.

3.6.2 Surface Correction and Testing

After all other finishing is completed but while the concrete is still plastic, eliminate minor irregularities and score marks in the pavement surface by means of cutting straightedges. Use straightedges 12 feet in length and operate from the sides of the pavement and from bridges. Equip a straightedge operated from the side of the pavement with a handle 3 feet longer than one-half the width of the pavement. Then test the surface for trueness with a straightedge held in successive positions parallel and at right angles to the center line of the pavement, and the whole area covered as necessary to detect variations. Advance the straightedge along the pavement in successive stages of not more than one-half the length of the straightedge. Immediately fill depressions with freshly mixed concrete, then strike off, consolidate, and refinish. Strike off and refinish projections above the required elevation. Produce the surface finish of the pavement essentially by the finishing machine and not by subsequent hand finishing operations. All hand finishing operations are subject to approval and must be modified when directed.

3.6.2.1 Edge Slump

Determine slump of edges with a 12 foot straightedge. Before the concrete hardens, correct edge slump of pavement exceeding 1/4 inch at edge of pavement. Limit the area affected by the downward movement of the concrete along the pavement edge to not more than 18 inches from the edge.

3.6.3 Hand Finishing

As soon as placed and consolidated, strike off and screed concrete to required cross section. If necessary, place and screed additional concrete and float until a satisfactory surface has been produced. Advance floating operation not more than half the length of the float and then continue over new and previously floated surfaces. Limit hand finishing to small irregular areas not accessible with finishing machine.

3.6.4 Texturing

Before the surface sheen has disappeared and before the concrete hardens, give the surface of the pavement a texture as described herein. After curing is complete, thoroughly power broom all textured surfaces to remove all debris.

REPAIR AIRFIELD RAMP LIGHTS

3.6.4.1 Burlap Drag Surface

Apply surface texture by dragging the surface of the pavement, in the direction of the concrete placement, with an approved burlap drag. Operate the drag with the fabric moist, and the fabric clean; change as required to keep clean. Perform the dragging so as to produce a uniform finished surface having a fine sandy texture without disfiguring marks.

3.6.5 Edging

After texturing has been completed, carefully finish the edge of the slabs along the forms and at the joints with an edging tool to form a smooth rounded surface of 1/8 inch radius. Eliminate tool marks, smooth the edges and make true to line. Do not add water to the surface during edging. Take extreme care to prevent overworking the concrete.

3.6.6 Outlets in Pavement

Construct recesses for the tie-down anchors, lighting fixtures, and other outlets in the pavement to conform to the details and dimensions shown. Carefully finish the concrete in these areas to provide a surface of the same texture as the surrounding area that will be within the requirements for plan grade and surface smoothness.

3.7 CURING

3.7.1 Protection of Concrete

Continuously protect concrete against loss of moisture and rapid temperature changes for at least 7 days from the completion of finishing operations. Keep all equipment needed for adequate curing and protection of the concrete on hand and ready for use before actual concrete placement begins. If any selected method of curing does not afford the proper curing and protection against concrete cracking, remove and replace the damaged pavement, and employ another method of curing as directed. Accomplish curing by one of the following methods.

3.7.2 Membrane Curing

Apply a uniform coating of white-pigmented, membrane-forming, curing compound to the entire exposed surface of the concrete as soon as the free water has disappeared from the surface after moist curing ceases. Along the formed edge faces, apply it immediately after the forms are removed. Do not allow concrete to dry before the application of the membrane. If any drying has occurred, moisten the surface of the concrete with a fine spray of water, and apply the curing compound as soon as the free water disappears. Apply the curing compound to the finished surfaces by means of an approved automatic spraying machine. Apply the curing compound with an overlapping coverage that will give a two-coat application at a coverage of 400 square feet per gallon, plus or minus 5.0 percent for each coat. A one-coat application may be applied provided a uniform application and coverage of 200 square feet per gallon, plus or minus 5.0 percent is obtained. Apply the curing compound with a single overlapping application that will give a uniform coverage of 150 square feet per gallon. Permit the application of curing compound by hand-operated, mechanical powered pressure sprayers only on odd widths or shapes of slabs and on concrete surfaces exposed by the removal of forms. When the application is made by hand-operated sprayers, apply a second coat in a direction approximately at right angles to the direction of the first coat. If pinholes, abrasions,

REPAIR AIRFIELD RAMP LIGHTS

or other discontinuities exist, apply an additional coat to the affected areas within 30 minutes. Respray concrete surfaces that are subjected to heavy rainfall within 3 hours after the curing compound has been applied by the method and at the coverage specified above. Immediately respray areas where the curing compound is damaged by subsequent construction operations within the curing period. Protect concrete surfaces to which membrane-curing compounds have been applied during the entire curing period from pedestrian and vehicular traffic, except as required for joint-sawing operations and surface tests, and from any other possible damage to the continuity of the membrane.

3.7.3 Moist Curing

Maintain concrete to be moist-cured continuously wet for the entire curing period, or until curing compound is applied, commencing immediately after finishing. If forms are removed before the end of the curing period, perform curing as on unformed surfaces, using suitable materials. Cure surfaces by ponding, by continuous sprinkling, by continuously saturated burlap or cotton mats, or by continuously saturated plastic coated burlap. Use burlap and mats that are clean and free from any contamination and completely saturate before placing on the concrete. Lap sheets to provide full coverage. The Contractor must have an approved work system to ensure that moist curing is continuous 24 hours per day and that the entire surface is wet.

3.8 JOINTS

3.8.1 General Requirements for Joints

Joints must conform to the locations and details indicated and must be perpendicular to the finished grade of the pavement. Ensure all joints are straight and continuous from edge to edge or end to end of the pavement with no abrupt offset and no gradual deviation greater than 1/2 inch. Where any joint fails to meet these tolerances, remove the slabs adjacent to the joint and replace at no additional cost to the Government. Make no change from the jointing pattern shown on the drawings without written approval of the Contracting Officer. Seal joints immediately following curing of the concrete or as soon thereafter as weather conditions permit.

3.8.2 Longitudinal Construction Joints

After the end of the curing period, saw longitudinal construction joints to provide a groove at the top for sealant conforming to the details and dimensions indicated.

3.8.3 Transverse Construction Joints

Install transverse construction joints at the end of each day's placing operations and at any other points when concrete placement is interrupted for 30 minutes or longer. Install the transverse construction joint at a planned transverse joint. Construct transverse construction joints by utilizing headers or by paving through the joint, then full-depth saw cutting the excess concrete. Construct transverse construction joints installed at a planned transverse joint as shown or, if not shown otherwise, use dowels. Insert dowels through the header into the fresh concrete and consolidated with hand-held vibrators.

REPAIR AIRFIELD RAMP LIGHTS

3.8.4 Expansion Joints

Form expansion joints where indicated, and about any structures and features that project through or into the pavement, using joint filler of the type, thickness, and width indicated, and install to form a complete, uniform separation between the structure and the pavement. Attach the filler to the original concrete placement with adhesive or other fasteners and extend the full slab depth. Fit adjacent sections of filler tightly together in order to prevent entrance of concrete into the expansion space. Finish edges of the concrete at the joint face with an edger with a radius of 1/8 inch. Install the joint filler strips 3/4 inch below the pavement surface with a slightly tapered, dressed-and-oiled wood strip or other approved material temporarily secured to the top of the filler to form a recess to be filled with joint sealant. Construct expansion joints with thickened edges for load transfer.

3.8.5 Contraction Joints

Construct transverse and longitudinal contraction joints by sawing an initial groove in the concrete with a 1/8 inch blade to the indicated depth. During sawing of joints, and again 24 hours later, the CQC team must inspect all exposed edges for development of cracks below the saw cut, and immediately report results to the Contracting Officer. If the Contracting Officer determines that there are more uncracked joints than desired, the Contractor will be directed to saw succeeding joints 25 percent deeper than originally indicated at no additional cost to the Government. Commence sawing of the joints as soon as the concrete has hardened sufficiently to permit cutting the concrete without chipping, spalling, or tearing. Use a chalk line or other suitable guide to mark the alignment of the joint. Immediately after the joint is sawed, thoroughly flush the saw cut and adjacent concrete surface with water and vacuum until all waste from sawing is removed from the joint and adjacent concrete surface. Respray the surface with curing compound as soon as free water disappears. Take necessary precautions to ensure that the concrete is properly protected from damage and cured at sawed joints, but that no curing compound enters the joints. Tightly seal the top of the joint opening and the joint groove at exposed edges with cord backer rod before the concrete in the region of the joint is resprayed with curing compound, and maintain until removed immediately before sawing joint sealant reservoir. After expiration of the curing period, widen the upper portion of the groove by sawing to the width and depth indicated for the joint sealer.

3.8.6 Thickened Edge Joints

Construct thickened edge joints as indicated on the drawings. Grade underlying material in the transition area as shown and meet the requirements for smoothness and compaction specified for all other areas of the underlying material.

3.9 REPAIR, REMOVAL, REPLACEMENT OF NEWLY CONSTRUCTED SLABS

3.9.1 General Criteria

Remove and replace or repair new pavement slabs that are broken, have spalled edges, or contain cracks, as specified hereinafter at no cost to the Government. Removal of partial slabs is not permitted. Do not spall more than 15.0 percent of each slab's edge. Slabs with spalls exceeding this quantity, regardless of spall size, must be sawn full depth to remove

REPAIR AIRFIELD RAMP LIGHTS

the spalled face, or removed, as directed. The Contracting Officer will determine whether cracks extend full depth of the pavement and may require cores to be drilled on the crack to determine depth of cracking. Ensure such cores are at least 6 inch diameter, and drilled and backfilled with a well consolidated concrete mixture bonded to the walls of the hole with Type V, Grade 3 epoxy resin. Drilling of cores and refilling holes shall be performed by the Contractor at no expense to the Government.

3.9.2 Slabs with Cracks

Clean cracks that do not exceed 25 percent of the design thickness in depth and then pressure inject full depth with epoxy resin, Type IV, Grade 1. Remove slabs containing cracks deeper than 25 percent of the design thickness.

3.9.3 Repairing Spalls Along Joints

Repair details and materials must conform to UFC 3-270-03.

3.10 EXISTING CONCRETE PAVEMENT REMOVAL AND REPAIR

Prior to commencing pavement removal operations, the Contractor must inventory the pavement distresses (cracks, spalls, and corner breaks) along the pavement edge to remain. After pavement removal, the Contractor must again survey the remaining edge to quantify any damage caused by Contractor's removal operations. Both surveys must be performed by the Contractor, in the presence of the Contracting Officer. Make repairs as indicated and as specified herein. Carefully control all operations to prevent damage to the concrete pavement and to the underlying material to remain in place. Make all saw cuts perpendicular to the slab surface, forming rectangular areas.

3.10.1 Removal of Existing Pavement Slab

When existing concrete pavement is to be removed and adjacent concrete is to be left in place, first cut the joint between the removal area and adjoining pavement to stay in place full depth with a standard diamond-type concrete saw. Next, make a full depth saw cut parallel to the joint at least 24 inches from the joint and at least 6 inches from the end of any dowels. Make this saw cut with a wheel saw as specified in paragraph: Sawing Equipment. Remove all pavement to be removed beyond this last saw cut in accordance with the approved demolition work plan. Remove all pavement between this last saw cut and the joint line by carefully pulling pieces and blocks away from the joint face with suitable equipment and then picking them up for removal. In lieu of this method, this strip of concrete may be carefully broken up and removed using hand-held jackhammers, 30 lb or less, or other approved light-duty equipment which will not cause stress to propagate across the joint saw cut and cause distress in the pavement which is to remain in place. In lieu of the above specified removal method, the slab may be sawcut full depth to divide it into several pieces and each piece lifted out and removed. Use suitable equipment to provide a truly vertical lift, and use safe lifting devices for attachment to the slab.

3.10.2 Edge Repair

Protect the edge of existing concrete pavement against which new pavement abuts from damage at all times. Remove areas which are damaged during construction and replaced as directed by the Contracting Officer at no cost

REPAIR AIRFIELD RAMP LIGHTS

to the Government. Repair of previously existing damage areas will be considered a subsidiary part of concrete pavement construction.

3.10.2.1 Spall Repair

Not more than 15.0 percent of each slab's edge shall be spalled as a result of the Contractor's actions. Slabs with spalls exceeding this quantity, regardless of spall size, must be sawn full depth to remove the spalled face. Repair spalls along joints and along cracks where indicated and where directed. Use repair materials and procedures as previously specified in paragraph: Repairing Spalls Along Joints.

3.10.2.2 Underbreak and Underlying Material

Repair all underbreak by removal and repair of the damaged slabs in accordance with paragraph: Removal and Replacement of Full Slabs. Protect the underlying material adjacent to the edge of and under the existing pavement which is to remain in place from damage or disturbance during removal operations and until placement of new concrete, and shape as shown on the drawings or as directed. Keep sufficient underlying material in place outside the joint line to completely prevent disturbance of material under the pavement which is to remain in place. Carefully remove any material under the portion of the concrete pavement to remain in place which is disturbed or loses its compaction and replace with concrete.

3.11 PAVEMENT PROTECTION

Protect the pavement against all damage prior to final acceptance by the Government. Do not pile aggregates, rubble, or other similar construction materials on airfield pavements. Block traffic from the new pavement by erecting and maintaining barricades and signs until the concrete is at least 14 days old, or for a longer period if so directed. Equipment to ride upon the edges of previously constructed slabs when the concrete has attained a minimum field cured flexural strength of 550 psi and approved means are furnished to prevent damage to the slab edge. Keep all new and existing pavement carrying construction traffic or equipment completely clean, and clean up spillage of concrete or other materials immediately upon occurrence.

3.12 TESTING AND INSPECTION FOR CONTRACTOR QUALITY CONTROL

Sampling and testing shall be conducted on site at the expense of the Contractor, by a laboratory approved by the Contracting Officer. Supply samples as specified at the expense of the Contractor.

3.12.1 Sampling

3.12.1.1 Aggregates

Sample fine and coarse aggregates at the batch plant. Sample in accordance with ASTM D 75.

3.12.1.2 Concrete

Obtain samples of plastic concrete in accordance with ASTM C 172. Quality control samples may be taken at the concrete batch plant; however, samples for verification of concrete strength and slump for submittal to the Government shall be taken in accordance with ASTM C 172 at the job-site as concrete is delivered. From each sample, mold the required number of beams

REPAIR AIRFIELD RAMP LIGHTS

and cylinders for each group of test specimens.

3.12.1.3 Sample Identification

Tag each for identification. Tag must contain the following information:

Contract No. _____
Sample No. _____
Date of Sample _____
Sample _____
Source _____
Intended Use _____
For Testing _____

3.12.2 Testing

3.12.2.1 Aggregate Tests

Perform gradation tests on each sample. Make other aggregate tests on initial source samples, and repeat tests whenever there is a change of source. During progress of concrete placement, perform gradation tests for fine and coarse aggregates. Include sieve analysis according to ASTM C 136 for each fractional size and gradation analysis of the combined material representing the aggregate part of the concrete mix.

3.12.2.2 Concrete Testing

- a. Concrete Slump: Test consistency of concrete slump in accordance with ASTM C 143/C 143M. Determine consistency of concrete at the start of each day's concrete placement and for each group of test specimens.
- b. Air Content: Determine air content at the start of concrete placement and for each group of test specimens. Record results with test specimens. Determine air content in accordance with ASTM C 231.
- c. Surface Tests: Perform straightedge testing in accordance with paragraph: Surface Testing. Where defective areas of pavement are removed or replaced, the portion of the slab which remains in the pavement abutting the replacement slab shall have length and width not less than 10 feet from the nearest edge or joint.
- d. Test for Pavement Thickness: Obtain 4 inch diameter core samples to determine in-place thickness of concrete pavement. Obtain cores in accordance with ASTM C 42/C 42M. Remove cores at varying intervals but in no case less than two cores for each 1000 square yards. Repair core holes with non-shrink grout. Measure cores in accordance with ASTM C 174/C 174M. A tolerance in pavement thickness of plus or minus 1/2 inch is permitted for individual core; however, the average thickness of cores must be at least as thick as the pavement section requires. When determining the average, assign cores with a thickness of more than 1/2 inch

REPAIR AIRFIELD RAMP LIGHTS

greater than specified, a thickness of the specified thickness plus 1/2 inch. If measured pavement thickness is less than that shown by more than 1/2 inch, remove deficient areas and replace with pavement of the specified strength, quality and thickness. When a core indicates unsatisfactory thickness, determine limits of the pavement to be removed and replaced as follows: Take one core for each slab of lane in question in both directions from unsatisfactory core until satisfactory thickness is indicated; remove and replace pavement in each panel, for the full width of the lane, in which a core indicated unsatisfactory thickness. Include the following information in each of the reports of corings:

- (1) Date concrete represented by core was placed
 - (2) Date core was taken
 - (3) Location of Core: Lane number, station number
 - (4) Thickness of core
 - (5) Condition of Core: Appearance, concrete texture, condition of bottom of core
 - (6) Disposition of Cores: In Contracting Officer or Contractor possession.
- e. Flexural Strength: During progress of work verify flexural strength by testing beams made from concrete taken from the delivery vehicle at intervals specified herein. Mold and cure beams in accordance with ASTM C 31/C 31M. Perform tests in accordance with ASTM C 78. Mold at least eight beams each day from concrete placed that day. Select one group of four beams near the beginning of the work and a second group of four beams from the final third of concrete to be placed that day. Ensure an approved laboratory furnishes necessary labor, concrete and facilities for molding, handling, and storing the beams at the site of the work and testing beams. Perform tests at 28 days and 90 days. Earlier tests may be performed at the contractor's request, with no additional cost to the Government. Concrete must meet the following requirements:
- (1) From each group of four beams, three beams tested at the end of 90 days must have an average flexural strength equal to or greater than the specified strength. Do not consider specimens obviously defective in the determination of the strengths.
 - (2) No individual beam of the three beams tested shall have a flexural strength less than 600 psi. Discard defective beams.
 - (3) Test one beam of the group at 28 days. If the ratio of the 28-day strength test to the specified 90-day strength is less than expected, make necessary adjustments for conformance.
 - (4) When a satisfactory relationship between 28-day and 90-day strengths has been established and approved by the Contracting Officer or his authorized representative, the 28-day test results may be used as an indication of the 90-day strengths. Remove or otherwise correct concrete which does not meet the specified

REPAIR AIRFIELD RAMP LIGHTS

strength, at the Contractor's expense, with corrective methods subject to the approval of the Contracting Officer or his authorized representative.

(5) If the 90 day strength test results do not meet the requirements specified herein, the contractor shall take a minimum of three ASTM C 42/C 42M core samples from the in-place work represented by the low strength test results and test, at no cost to the Government, as long as compressive strength test results were performed at the same time as flexural strength tests and were submitted with the original mix design. Consider concrete represented by core tests structurally adequate if the average of the three cores is equal to at least 100 percent of the specified design strength. Remove concrete not meeting the strength criteria and provide new, acceptable concrete. Repair core holes with non-shrink grout. Match color and finish of adjacent concrete.

- f. Control Charts: Maintain control charts for concrete flexural strength in accordance with ACI 214R Appendix, except as otherwise modified herein. Post copies of charts at the job site. Indicate specified strength and average strength determined by the mix design. Each control chart must consist of the following plots:

(1) Test Results: At the same location, plot each individual test strength (the beam tested at 28 days and the average results of three beams tested at 90 days).

(2) Moving Average for Strength: Moving average of five consecutive tests ACI 214R

3.12.3 Reports

- a. Report all results of tests or inspections conducted informally as they are completed and in writing daily. Prepare a weekly report for the updating of control charts covering the entire period from the start of the construction season through the current week. During periods of cold-weather protection, make reports of pertinent temperatures daily. These requirements do not relieve the Contractor of the obligation to report certain failures immediately as required in preceding paragraphs. Confirm such reports of failures and the action taken in writing in the routine reports. The Contracting Officer has the right to examine all contractor quality control records.
- b. Provide hardcopy documentation on Compact Disc (CD) for all preconstruction, production quality control, and acceptance testing for cementitious materials, aggregates, mineral and chemical admixtures, and fresh/hardened concrete. Cross-reference all production quality control and acceptance testing by pavement lot number and correlate to a placement map. The required format for the database will be provided by the Contracting Officer.

-- End of Section --

BLANK PAGE

SECTION 33 70 02.00 10

ELECTRICAL DISTRIBUTION SYSTEM, UNDERGROUND
11/08

PART 1 GENERAL

1.1 REFERENCES

The publications listed below form a part of this specification to the extent referenced. The publications are referred to within the text by the basic designation only.

ALLIANCE FOR TELECOMMUNICATIONS INDUSTRY SOLUTIONS (ATIS)

ATIS O5.1 (2008) Specifications and Dimensions (for Wood Poles)

ASSOCIATION OF EDISON ILLUMINATING COMPANIES (AEIC)

AEIC C8 (2000) Extruded Dielectric Shielded Power Cables Rated 5 Through 46 kV

AEIC CS8 (2000) Extruded Dielectric Shielded Power Cables Rated 5 Through 46 kV

ASTM INTERNATIONAL (ASTM)

ASTM A 123/A 123M (2008) Standard Specification for Zinc (Hot-Dip Galvanized) Coatings on Iron and Steel Products

ASTM A 153/A 153M (2005) Standard Specification for Zinc Coating (Hot-Dip) on Iron and Steel Hardware

ASTM A 48/A 48M (2003; R 2008) Standard Specification for Gray Iron Castings

ASTM B 117 (2007a) Standard Practice for Operating Salt Spray (Fog) Apparatus

ASTM B 3 (2001; R 2007) Standard Specification for Soft or Annealed Copper Wire

ASTM B 496 (2004) Standard Specification for Compact Round Concentric-Lay-Stranded Copper Conductors

ASTM B 8 (2004) Standard Specification for Concentric-Lay-Stranded Copper Conductors, Hard, Medium-Hard, or Soft

ASTM C 478 (2008) Standard Specification for Precast Reinforced Concrete Manhole Sections

ASTM C 478M (2008e1) Standard Specification for

REPAIR AIRFIELD RAMP LIGHTS

	Precast Reinforced Concrete Manhole Sections (Metric)
ASTM D 1654	(2008) Evaluation of Painted or Coated Specimens Subjected to Corrosive Environments
ASTM D 2472	(2000; R 2006) Standard Specification for Sulphur Hexafluoride
ASTM D 4059	(2000; R 2005e1) Analysis of Polychlorinated Biphenyls in Insulating Liquids by Gas Chromatography
ASTM D 923	(2007) Standard Practice for Sampling Electrical Insulating Liquids
FM GLOBAL (FM)	
FM P7825a	(2005) Approval Guide Fire Protection
INSTITUTE OF ELECTRICAL AND ELECTRONICS ENGINEERS (IEEE)	
IEEE C2	(2007; Errata 2007; INT 2008) National Electrical Safety Code
IEEE C37.1	(2007) Definition, Specification, and Analysis of Systems Used for Supervisory Control, Data Acquisition, and Automatic Control
IEEE C37.121	(1989; R 2006) American National Standard for Switchgear Unit Substations Requirements
IEEE C37.13	(1990; R 1995) Standard for Low-Voltage AC Power Circuit Breakers Used in Enclosures
IEEE C37.16	(2000) Recommendations for Low-Voltage Power Circuit Breakers and AC Power Circuit Protectors, - Preferred Ratings, Related Requirements, and Application
IEEE C37.2	(2008) Electrical Power System Device Function Numbers and Contact Designations
IEEE C37.20.1	(2002; Addenda A 2005; Addenda B 2006; R 2007) Standard for Metal-Enclosed Low-Voltage Power Circuit-Breaker Switchgear
IEEE C37.20.2	(1999) Metal-Clad Switchgear
IEEE C37.20.3	(2001; R 2006) Metal-Enclosed Interrupter Switchgear
IEEE C37.30	(1997) Requirements for High-Voltage Switches

REPAIR AIRFIELD RAMP LIGHTS

IEEE C37.34	(1994) Test Code for High-Voltage Air Switches
IEEE C37.41	(2000) Design Tests for High-Voltage Fuses, Distribution Enclosed Single-Pole Air Switches, Fuse Disconnecting Switches, and Accessories
IEEE C37.46	(2000) For High Voltage Expulsion and Current-Limiting Type Power Class Fuses and Fuse Disconnecting Switches
IEEE C37.90	(2005) Standard for Relays and Relay Systems Associated With Electric Power Apparatus
IEEE C57.12.00	(2006) Standard General Requirements for Liquid-Immersed Distribution, Power, and Regulating Transformers
IEEE C57.12.21	(1992) Requirements for Pad-Mounted, Compartmental-Type, Self-Cooled, Single-Phase Distribution Transformers with High-Voltage Bushings; High Voltage, 34 500 Grd Y/199200 Volts and Below; Low Voltage, 2400/120 Volts; 167 kVA and Smaller
IEEE C57.12.26	(1992; Addenda 1993) Transformers - Pad-Mounted Compartmental-Type, Self-Cooled, Three-Phase Distribution Transformers for Use with Separable Insulated High-Voltage Connectors, High Voltage, (34 500 Grd Y/19 920 and Below; 2500 kVA and Smaller)
IEEE C57.12.28	(2005) Standard for Pad-Mounted Equipment - Enclosure Integrity
IEEE C57.13	(2008) Standard Requirements for Instrument Transformers
IEEE C62.11	(2005; Amendment A 2008) Standard for Metal-Oxide Surge Arresters for Alternating Current Power Circuits (>1kV)
IEEE Std 242	(2001; Errata 2003) Recommended Practice for Protection and Coordination of Industrial and Commercial Power Systems - Buff Book
IEEE Std 386	(2006) Standard for Separable Insulated Connector Systems for Power Distribution Systems Above 600V
IEEE Std 399	(1997) Recommended Practice for Power Systems Analysis - Brown Book
IEEE Std 404	(2006) Extruded and Laminated Dielectric

REPAIR AIRFIELD RAMP LIGHTS

Shielded Cable Joints Rated 2500 V Through
500 000 V

IEEE Std 48 (1996; R 2003) Test Procedures and
Requirements for Alternating-Current Cable
Terminations 2.5 kV through 765 kV

IEEE Std 81 (1983) Guide for Measuring Earth
Resistivity, Ground Impedance, and Earth
Surface Potentials of a Ground System
(Part 1) Normal Measurements

NATIONAL ELECTRICAL MANUFACTURERS ASSOCIATION (NEMA)

NEMA AB 1 (2002) Molded-Case Circuit Breakers,
Molded Case Switches, and Circuit-Breaker
Enclosures

NEMA C119.1 (2006) Sealed Insulated Underground
Connector Systems Rated 600 Volts

NEMA C12.10 (2004) Physical Aspects of Watthour Meters

NEMA C12.11 (2007) Instrument Transformers for Revenue
Metering, 10 kV BIL through 350 kV BIL
(0.6 kV NSV through 69 kV NSV)

NEMA C12.4 (1984; R 2002) Mechanical Demand Registers

NEMA C29.1 (1988; R 2002) Test Methods for Electrical
Power Insulators

NEMA C37.50 (1989; R 2000) Low-Voltage AC Power
Circuit Breakers Used in Enclosures - Test
Procedures

NEMA C80.1 (2005) Standard for Electrical Rigid Steel
Conduit (ERSC)

NEMA FB 1 (2007) Standard for Fittings, Cast Metal
Boxes, and Conduit Bodies for Conduit,
Electrical Metallic Tubing, and Cable

NEMA FU 1 (2002; R 2007) Low Voltage Cartridge Fuses

NEMA LA 1 (1992; R 1999) Standard for Surge Arresters

NEMA SG 2 (1993) Standard for High-Voltage Fuses

NEMA TC 6 & 8 (2003) Standard for Polyvinyl Chloride PVC
Plastic Utilities Duct for Underground
Installations

NATIONAL FIRE PROTECTION ASSOCIATION (NFPA)

NFPA 70 (2007; AMD 1 2008) National Electrical
Code - 2008 Edition

REPAIR AIRFIELD RAMP LIGHTS

UNDERWRITERS LABORATORIES (UL)

UL 1242	(2006; Rev thru Jul 2007) Standard for Electrical Intermediate Metal Conduit -- Steel
UL 198M	(2003; Rev thru Oct 2007) Mine-Duty Fuses
UL 467	(2007) Standard for Grounding and Bonding Equipment
UL 486A-486B	(2003; Rev thru Aug 2006) Standard for Wire Connectors
UL 489	(2002; Rev thru Jun 2006) Standard for Molded-Case Circuit Breakers, Molded-Case Switches and Circuit-Breaker Enclosures
UL 510	(2005; Rev thru Aug 2005) Polyvinyl Chloride, Polyethylene, and Rubber Insulating Tape
UL 514A	(2004; Rev thru Aug 2007) Standard for Metallic Outlet Boxes
UL 6	(2007) Standard for Electrical Rigid Metal Conduit-Steel
UL 651	(2005; Rev thru May 2007) Standard for Schedule 40 and 80 Rigid PVC Conduit and Fittings
UL 854	(2004; Rev thru Oct 2007) Service-Entrance Cables

1.2 SUBMITTALS

Submit the following in accordance with Section 01 11 00 SPECIAL CONDITIONS, Paragraph 1.2:

SD-02 Shop Drawings

Detail Drawings
As-Built Drawings

Drawings, as specified.

SD-03 Product Data

Fault Current Analysis; G
Protective Device; G
Coordination Study; G

The study with protective device equipment submittals. No time extension or similar contract modifications will be granted for work arising out of the requirements for this study. Approval of protective devices proposed shall be based on recommendations of this study. The Government will not be responsible for any changes to equipment, device ratings, settings, or additional

REPAIR AIRFIELD RAMP LIGHTS

labor for installation of equipment or devices ordered and/or procured prior to approval of the study.

Nameplates; G

Catalog cuts, brochures, circulars, specifications, product data, and printed information in sufficient detail and scope to verify compliance with the requirements of the contract documents.

Material and Equipment; G

A complete itemized listing of equipment and materials proposed for incorporation into the work. Each entry shall include an item number, the quantity of items proposed, and the name of the manufacturer of each such item.

Installation Requirements; G

As a minimum, installation procedures for transformers, substations, switchgear, and splices. Procedures shall include cable pulling plans, diagrams, instructions, and precautions required to install, adjust, calibrate, and test the devices and equipment.

SD-06 Test Reports

Factory Tests

Certified factory test reports shall be submitted when the manufacturer performs routine factory tests, including tests required by standards listed in paragraph REFERENCES. Results of factory tests performed shall be certified by the manufacturer, or an approved testing laboratory, and submitted within 7 days following successful completion of the tests. The manufacturer's pass-fail criteria for tests specified in paragraph FIELD TESTING shall be included.

Field Testing

A proposed field test plan, 20 days prior to testing the installed system. No field test shall be performed until the test plan is approved. The test plan shall consist of complete field test procedures including tests to be performed, test equipment required, and tolerance limits.

Operating Tests

Six copies of the tests report in 8-1/2 by 11 inch binders having a minimum of three rings, including a separate section for each test. Sections shall be separated by heavy plastic dividers with tabs.

Cable Installation

Six copies of the information described below in 8-1/2 by 11 inch binders having a minimum of three rings from which material may readily be removed and replaced, including a separate section for each cable pull. Sections shall be separated by heavy plastic dividers with tabs, with all data sheets signed and dated by the

REPAIR AIRFIELD RAMP LIGHTS

person supervising the pull.

- a. Site layout drawing with cable pulls numerically identified.
- b. A list of equipment used, with calibration certifications. The manufacturer and quantity of lubricant used on pull.
- c. The cable manufacturer and type of cable.
- d. The dates of cable pulls, time of day, and ambient temperature.
- e. The length of cable pull and calculated cable pulling tensions.
- f. The actual cable pulling tensions encountered during pull.

SD-07 Certificates

Material and Equipment

Where materials or equipment are specified to conform to the standards of the Underwriters Laboratories (UL) or to be constructed or tested, or both, in accordance with the standards of the American National Standards Institute (ANSI), the Institute of Electrical and Electronics Engineers (IEEE), or the National Electrical Manufacturers Association (NEMA), submit proof that the items provided conform to such requirements. The label of, or listing by, UL will be acceptable as evidence that the items conform. Either a certification or a published catalog specification data statement, to the effect that the item is in accordance with the referenced ANSI or IEEE standard, will be acceptable as evidence that the item conforms. A similar certification or published catalog specification data statement to the effect that the item is in accordance with the referenced NEMA standard, by a company listed as a member company of NEMA, will be acceptable as evidence that the item conforms. In lieu of such certification or published data, the Contractor may submit a certificate from a recognized testing agency equipped and competent to perform such services, stating that the items have been tested and that they conform to the requirements listed, including methods of testing of the specified agencies. Compliance with above-named requirements does not relieve the Contractor from compliance with any other requirements of the specifications.

Cable Joints

A certification that contains the names and the qualifications of people recommended to perform the splicing and termination of medium-voltage cables approved for installation under this contract. The certification shall indicate that any person recommended to perform actual splicing and terminations has been adequately trained in the proper techniques and have had at least three recent years of experience in splicing and terminating the same or similar types of cables approved for installation. In addition, any person recommended by the Contractor may be required to perform a practice splice and termination, in the presence of the Contracting Officer, before being approved as a qualified

REPAIR AIRFIELD RAMP LIGHTS

installer of medium-voltage cables. If that additional requirement is imposed, provide short sections of the approved types of cables along with the approved type of splice and termination kits, and detailed manufacturer's instruction for the proper splicing and termination of the approved cable types.

Installation Engineer

Provide at least one onsite person in a supervisory position with a documentable level of competency and experience to supervise all cable pulling operations. A resume shall be provided showing the cable installers' experience in the last three years, including a list of references complete with points of contact, addresses and telephone numbers.

SD-10 Operation and Maintenance Data

Operation and Maintenance Manuals

Six copies of operation and maintenance manuals, within 7 calendar days following the completion of tests and including assembly, installation, operation and maintenance instructions, spare parts data which provides supplier name, current cost, catalog order number, and a recommended list of spare parts to be stocked. Manuals shall also include data outlining detailed procedures for system startup and operation, and a troubleshooting guide which lists possible operational problems and corrective action to be taken. A brief description of all equipment, basic operating features, and routine maintenance requirements shall also be included. Documents shall be bound in a binder marked or identified on the spine and front cover. A table of contents page shall be included and marked with pertinent contract information and contents of the manual. Tabs shall be provided to separate different types of documents, such as catalog ordering information, drawings, instructions, and spare parts data. Index sheets shall be provided for each section of the manual when warranted by the quantity of documents included under separate tabs or dividers. Three additional copies of the instructions manual shall be provided within 30 calendar days following the manuals.

1.3 QUALITY ASSURANCE

1.3.1 Detail Drawings

Submit detail drawings consisting of equipment drawings, illustrations, schedules, instructions, diagrams manufacturers standard installation drawings and other information necessary to define the installation and enable the Government to check conformity with the requirements of the contract drawings.

a. If departures from the contract drawings are deemed necessary by the Contractor, complete details of such departures shall be included with the detail drawings. Approved departures shall be made at no additional cost to the Government.

b. Detail drawings shall show how components are assembled, function together and how they will be installed on the project. Data and drawings for component parts of an item or system shall be coordinated

REPAIR AIRFIELD RAMP LIGHTS

and submitted as a unit. Data and drawings shall be coordinated and included in a single submission. Multiple submissions for the same equipment or system are not acceptable except where prior approval has been obtained from the Contracting Officer. In such cases, a list of data to be submitted later shall be included with the first submission. Detail drawings shall consist of the following:

- 1). Detail drawings showing physical arrangement, construction details, connections, finishes, materials used in fabrication, provisions for conduit or busway entrance, access requirements for installation and maintenance, physical size, electrical characteristics, foundation and support details, and equipment weight. Drawings shall be drawn to scale and/or dimensioned. All optional items shall be clearly identified as included or excluded.
- 2). Internal wiring diagrams of equipment showing wiring as actually provided for this project. External wiring connections shall be clearly identified.
- 3). Detail drawings shall as a minimum depict the installation of the following items:
 - (a). Medium-voltage cables and accessories including cable installation plan.
 - (b). Transformers.
 - (c). Substations.
 - (d). Switchgear.
 - (e). Pad-mounted loadbreak switches.
 - (f). Busways.
 - (g). Surge arresters.

1.3.2 As-Built Drawings

The as-built drawings shall be a record of the construction as installed. The drawings shall include the information shown on the contract drawings as well as deviations, modifications, and changes from the contract drawings, however minor. The as-built drawings shall be a full sized set of prints marked to reflect deviations, modifications, and changes. The as-built drawings shall be complete and show the location, size, dimensions, part identification, and other information. Additional sheets may be added. The as-built drawings shall be jointly inspected for accuracy and completeness by the Contractor's quality control representative and by the Contracting Officer prior to the submission of each monthly pay estimate. Upon completion of the work, provide three full sized sets of the marked prints to the Contracting Officer for approval. If upon review, the as-built drawings are found to contain errors and/or omissions, they will be returned to the Contractor for correction. Correct and return the as-built drawings to the Contracting Officer for approval within 10 calendar days from the time the drawings are returned to the Contractor.

REPAIR AIRFIELD RAMP LIGHTS

1.4 DELIVERY, STORAGE, AND HANDLING

Visually inspect devices and equipment when received and prior to acceptance from conveyance. Protect stored items from the environment in accordance with the manufacturer's published instructions. Damaged items shall be replaced. Store oil filled transformers and switches in accordance with the manufacturer's requirements. Wood poles held in storage for more than 2 weeks shall be stored in accordance with ATIS O5.1. Handle wood poles in accordance with ATIS O5.1, except that pointed tools capable of producing indentations more than 1 inch in depth shall not be used. Metal poles shall be handled and stored in accordance with the manufacturer's instructions.

1.5 EXTRA MATERIALS

One additional spare fuse or fuse element for each furnished fuse or fuse element shall be delivered to the contracting officer when the electrical system is accepted. Two complete sets of all special tools required for maintenance shall be provided, complete with a suitable tool box. Special tools are those that only the manufacturer provides, for special purposes (to access compartments, or operate, adjust, or maintain special parts).

PART 2 PRODUCTS

2.1 STANDARD PRODUCT

Provide material and equipment which are the standard product of a manufacturer regularly engaged in the manufacture of the product and that essentially duplicate items that have been in satisfactory use for at least 2 years prior to bid opening. Items of the same classification shall be identical including equipment, assemblies, parts, and components.

2.2 NAMEPLATES

2.2.1 General

Each major component of this specification shall have the manufacturer's name, address, type or style, model or serial number, and catalog number on a nameplate securely attached to the equipment. Nameplates shall be made of noncorrosive metal. Equipment containing liquid dielectrics shall have the type of dielectric on the nameplate. Sectionalizer switch nameplates shall have a schematic with all switch positions shown and labeled. As a minimum, nameplates shall be provided for transformers, circuit breakers, meters, switches, and switchgear.

2.2.2 Liquid-Filled Transformer Nameplates

Power transformers shall be provided with nameplate information in accordance with IEEE C57.12.00. Nameplates shall indicate the number of gallons and composition of liquid-dielectric, and shall be permanently marked with a statement that the transformer dielectric to be supplied is non-polychlorinated biphenyl. If transformer nameplate is not so marked, furnish manufacturer's certification for each transformer that the dielectric is non-PCB classified, with less than 2 ppm PCB content in accordance with paragraph LIQUID DIELECTRICS. Certifications shall be related to serial numbers on transformer nameplates. Transformer dielectric exceeding the 2 ppm PCB content or transformers without certification will be considered as PCB insulated and will not be accepted.

REPAIR AIRFIELD RAMP LIGHTS

2.3 CORROSION PROTECTION

2.3.1 Aluminum Materials

Aluminum shall not be used.

2.3.2 Ferrous Metal Materials

2.3.2.1 Hardware

Ferrous metal hardware shall be hot-dip galvanized in accordance with ASTM A 153/A 153M and ASTM A 123/A 123M.

2.3.2.2 Equipment

Equipment and component items, including but not limited to transformer stations and ferrous metal luminaries not hot-dip galvanized or porcelain enamel finished, shall be provided with corrosion-resistant finishes which shall withstand 120 hours of exposure to the salt spray test specified in ASTM B 117 without loss of paint or release of adhesion of the paint primer coat to the metal surface in excess of 1/16 inch from the test mark. The scribed test mark and test evaluation shall be in accordance with ASTM D 1654 with a rating of not less than 7 in accordance with TABLE 1, (procedure A). Cut edges or otherwise damaged surfaces of hot-dip galvanized sheet steel or mill galvanized sheet steel shall be coated with a zinc rich paint conforming to the manufacturer's standard.

2.3.3 Finishing

Painting required for surfaces not otherwise specified and finish painting of items only primed at the factory shall be as specified in Section 09 90 00 PAINTS AND COATINGS.

2.4 CABLES

Cables shall be single conductor type unless otherwise indicated.

2.4.1 Medium-Voltage Cables

2.4.1.1 General

Cable construction shall be Type MV, conforming to NFPA 70 and UL 1072. Cables shall be manufactured for use in duct applications.

2.4.1.2 Ratings

Cables shall be rated for a circuit voltage of 25 kV.

2.4.1.3 Conductor Material

Underground cables shall be soft drawn copper complying with ASTM B 3 and ASTM B 8 for regular concentric and compressed stranding or ASTM B 496 for compact stranding.

2.4.1.4 Insulation

Cable insulation shall be ethylene-propylene-rubber (EPR) insulation conforming to the requirements of AEIC CS8. A 133 percent insulation level shall be used on 5 kV, 15 kV and 25 kV rated cables.

REPAIR AIRFIELD RAMP LIGHTS

2.4.1.5 Shielding

Cables rated for 2 kV and above shall have a semiconducting conductor shield, a semiconducting insulation shield, and an overall copper tape shield for each phase. The shield tape shall be sized to meet IEEE C2 requirements for a ground fault availability calculated to exceed the available fault current.

2.4.1.6 Neutrals

Neutral conductors shall be copper, employing the same insulation and jacket materials as phase conductors, except that a 600-volt insulation rating is acceptable.

2.4.1.7 Jackets

Cables shall be provided with a PVC jacket.

2.4.2 Low-Voltage Cables

Cables shall be rated 600 volts and shall conform to the requirements of NFPA 70, and must be UL listed for the application or meet the applicable section of either ICEA or NEMA standards.

2.4.2.1 Conductor Material

Underground cables shall be annealed copper complying with ASTM B 3 and ASTM B 8. Use of aluminum conductors is not permitted.

2.4.2.2 Insulation

Insulation must be in accordance with NFPA 70, and must be UL listed for the application or meet the applicable sections of either ICEA, or NEMA standards.

2.4.2.3 Jackets

Multiconductor cables shall have an overall PVC outer jacket.

2.4.2.4 Direct Buried

Single and multi-conductor cables shall be of a type identified for direct burial. Service entrance cables shall conform to UL 854 for Type USE service entrance cable.

2.4.2.5 In Duct

Cables shall be single-conductor cable, in accordance with NFPA 70.

2.5 CABLE JOINTS, TERMINATIONS, AND CONNECTORS

2.5.1 Medium-Voltage Cable Joints

Medium-voltage cable joints shall comply with IEEE Std 404. Medium-voltage cable terminations shall comply with IEEE Std 48. Joints shall be the standard products of a manufacturer and shall be either of the factory preformed type or of the kit type containing tapes and other required parts. Joints shall have ratings not less than the ratings of the cables

REPAIR AIRFIELD RAMP LIGHTS

on which they are installed. Splice kits may be of the heat-shrinkable type for voltages up to 15 kV, of the premolded splice and connector type, the conventional taped type, or the resin pressure-filled overcast taped type for voltages up to 35 kV; except that for voltages of 7.5 kV or less a resin pressure-filled type utilizing a plastic-tape mold is acceptable. Joints used in manholes, handholes, vaults and pull boxes shall be certified by the manufacturer for waterproof, submersible applications.

2.5.2 Medium-Voltage Separable Insulated Connectors

Separable insulated connectors shall comply with IEEE Std 386 and shall be of suitable construction or standard splice kits shall be used. Separable insulated connectors are acceptable for voltages up to 35 kV. Connectors shall be of the loadbreak type as indicated, of suitable construction for the application and the type of cable connected, and shall include cable shield adaptors. Separable insulated connectors shall not be used as substitutes for conventional permanent splices. External clamping points and test points shall be provided.

2.5.3 Low-Voltage Cable Splices

Low-voltage cable splices and terminations shall be rated at not less than 600 Volts. Splices in conductors No. 10 AWG and smaller shall be made with an insulated, solderless, pressure type connector, conforming to the applicable requirements of UL 486A-486B. Splices in conductors No. 8 AWG and larger shall be made with noninsulated, solderless, pressure type connector, conforming to the applicable requirements of UL 486A-486B. Splices shall then be covered with an insulation and jacket material equivalent to the conductor insulation and jacket. Splices below grade or in wet locations shall be sealed type conforming to NEMA C119.1 or shall be waterproofed by a sealant-filled, thick wall, heat shrinkable, thermosetting tubing or by pouring a thermosetting resin into a mold that surrounds the joined conductors.

2.5.4 Terminations

Terminations shall be in accordance with IEEE Std 48, Class 1 or Class 2; of the molded elastomer, wet-process porcelain, prestretched elastomer, heat-shrinkable elastomer, or taped type. Acceptable elastomers are track-resistant silicone rubber or track-resistant ethylene propylene compounds, such as ethylene propylene rubber or ethylene propylene diene monomer. Separable insulated connectors may be used for apparatus terminations, when such apparatus is provided with suitable bushings. Terminations shall be of the outdoor type, except that where installed inside outdoor equipment housings which are sealed against normal infiltration of moisture and outside air, indoor, Class 2 terminations are acceptable. Class 3 terminations are not acceptable. Terminations, where required, shall be provided with mounting brackets suitable for the intended installation and with grounding provisions for the cable shielding, metallic sheath, and armor.

2.5.4.1 Factory Preformed Type

Molded elastomer, wet-process porcelain, prestretched, and heat-shrinkable terminations shall utilize factory preformed components to the maximum extent practicable rather than tape build-up. Terminations shall have basic impulse levels as required for the system voltage level. Leakage distances shall comply with wet withstand voltage test requirements of IEEE Std 48 for the next higher Basic Insulation Level (BIL) level.

REPAIR AIRFIELD RAMP LIGHTS

2.5.4.2 Taped Terminations

Taped terminations shall use standard termination kits providing terminal connectors, field-fabricated stress cones, and rain hoods. Terminations shall be at least 25 inches long from the end of the tapered cable jacket to the start of the terminal connector, or not less than the kit manufacturer's recommendations, whichever is greater.

2.6 CONDUIT AND DUCTS

Ducts shall be single, round-bore type, with wall thickness and fittings suitable for the application. Duct lines shall be concrete-encased, thin-wall type.

2.6.1 Metallic Conduit

Intermediate metal conduit shall comply with UL 1242. Rigid galvanized steel conduit shall comply with UL 6 and NEMA C80.1. Metallic conduit fittings and outlets shall comply with UL 514A and NEMA FB 1.

2.6.2 Nonmetallic Ducts

2.6.2.1 Concrete Encased Ducts

UL 651 Schedule 40 or NEMA TC 6 & 8 Type EB.

2.6.2.2 Direct Burial

UL 651 Schedule 80, or NEMA TC 6 & 8 Type DB.

2.6.3 Conduit Sealing Compound

Compounds for sealing ducts and conduit shall have a putty-like consistency workable with the hands at temperatures as low as 35 degrees F, shall neither slump at a temperature of 300 degrees F, nor harden materially when exposed to the air. Compounds shall adhere to clean surfaces of fiber or plastic ducts; metallic conduits or conduit coatings; concrete, masonry, or lead; any cable sheaths, jackets, covers, or insulation materials; and the common metals. Compounds shall form a seal without dissolving, noticeably changing characteristics, or removing any of the ingredients. Compounds shall have no injurious effect upon the hands of workmen or upon materials.

2.7 MANHOLES, HANDHOLES, AND PULLBOXES

Manholes, handholes, and pullboxes shall be as indicated. Strength of manholes, handholes, and pullboxes and their frames and covers shall conform to the requirements of IEEE C2. Precast-concrete manholes shall have the required strength established by ASTM C 478, ASTM C 478M. Frames and covers shall be made of gray cast iron and a machine-finished seat shall be provided to ensure a matching joint between frame and cover. Cast iron shall comply with ASTM A 48/A 48M, Class 30B, minimum. Handholes for low voltage cables installed in parking lots, sidewalks, and turfed areas shall be fabricated from an aggregate consisting of sand and with continuous woven glass strands having an overall compressive strength of at least 10,000 psi and a flexural strength of at least 5,000 psi. Pullbox and handhole covers in sidewalks, and turfed areas shall be of the same material as the box. Concrete pullboxes shall consist of precast reinforced concrete boxes, extensions, bases, and covers.

REPAIR AIRFIELD RAMP LIGHTS

2.8 POLES AND HARDWARE

Poles and hardware shall be in accordance with Section 33 71 01 OVERHEAD TRANSMISSION AND DISTRIBUTION.

2.9 TRANSFORMERS, SUBSTATIONS, AND SWITCHGEAR

Transformers, substations, and switchgear shall be of the outdoor type having the ratings and arrangements indicated. Medium-voltage ratings of cable terminations shall be 25 kV between phases for 133 percent insulation level.

2.9.1 Secondary Unit Substation

Secondary unit substations shall comply with IEEE C37.121 and shall be of the radial type with an outgoing section mounted integrally on the transformer. Substations shall be subassembled and coordinated by one manufacturer and shall be shipped in complete sections ready for connection at the site. Complete sections shall include incoming, transformer, and outgoing sections and, where practicable, shall be shipped as one unit.

2.9.1.1 Incoming Section

Metal-enclosed interrupter switchgear consisting of fused, SF6-insulated, interrupters in series with automatic, visible blade disconnects shall be provided for protection of incoming circuits. SF6 gas shall conform to ASTM D 2472. Metal-enclosed interrupter switchgear shall comply with IEEE C37.30 for load-interrupter switches, NEMA SG 2 for power fuses, and shall be of the outdoor no-aisle type that meets or exceeds the requirements of applicable publications listed. Switch construction shall be of the manually-operated, "OPEN-CLOSED," SF6-insulated, load interrupter type equipped with a stored energy operator for quick-make quick-break to make operating speeds independent of manual switch operations. Where indicated, suitable bus or lug connections shall be provided to mount field-installed, slip-on, medium-voltage cable terminations for cable entering via conduit from below and a flanged throat suitable for direct connection to the associated transformer. Surge protection shall be provided in accordance with paragraph SURGE ARRESTERS. Switches shall be of the 2-position type, open-closed.

a. Ratings. Fuse continuous current ratings shall be as indicated for the transformer for an incoming line unit and for the line tie unit. Unless otherwise indicated, fuses shall be of the current limiting type. Switch ratings at 60 Hz shall be:

- Nominal voltage.....22 kV.
- Rated maximum voltage.....22 kV.
- Maximum symmetrical interrupting capacity.....as calculated.
- Maximum asymmetrical interrupting capacity.....as calculated.
- 3-Second short time current carrying capacity.....as calculated.
- Rated continuous current.....as calculated.
- BIL.....125 kV.

REPAIR AIRFIELD RAMP LIGHTS

b. Basic Requirements. The electrical devices listed below shall be rated for the application and voltage and current indicated. Unless otherwise noted, manufacturer's standard devices shall be provided and shall include the following:

- (1) A switch-operating handle with provisions for locking in either the open or closed position.
- (2) A switch mechanical position indicator.
- (3) A heater continuously energized to prevent condensation over an ambient temperature range of minus 5 degrees F to 40 degrees F at 90% relative humidity and wired in series with a cabinet door-actuated switch, so the heater is de-energized when doors are open. High-temperature thermal protection shall be included.
- (4) One-pole or 2-pole thermal-magnetic, molded-case circuit breakers suitable for the operating voltage for heater circuits.
- (5) Safety devices as necessary to ensure that the load interrupter switch is in the open position whenever unit doors are in the open position.
- (6) A key interlock if indicated.
- (7) An interface terminal block wired for required exterior connections.

2.9.1.2 Transformer Section

Transformers shall have two separate windings per phase and shall be of the less-flammable, liquid-insulated type with dimethyl silicone liquid. Transformers shall be suitable for outdoor use. Liquid-insulated transformers shall comply with IEEE C57.12.00, and shall have two 2-1/2 percent full capacity taps above and two 2-1/2 percent full capacity taps below rated voltage. Transformers shall be of the sealed tank type construction with welded-on cover. High-voltage terminals shall be provided in an air terminal chamber for incoming bottom entry cables. Low-voltage terminals shall be provided in an air terminal chamber for incoming for direct connection to the outgoing switchgear section. Low-voltage terminals shall be as shown on the drawings when facing the front, accessory side of the transformer. Transformer accessories and ratings at 60 Hz shall be as follows:

1. Three-phase capacity, self-cooled.....as indicated.
3. Impedance.....5.75 percent, stdr.
4. Temperature rise.....55/65 degrees C.
5. High-voltage winding.....22k volts.
7. Low-voltage winding.....480 volts.

Accessories:

REPAIR AIRFIELD RAMP LIGHTS

1. drain and filter connection.
2. filling and top filter press connection.
3. pressure-vacuum gauge.
4. dial type thermometer with alarm contacts.
5. magnetic liquid level indicator with high and low level alarm contacts.
6. pressure relief device with alarm contacts.
7. ground connection pad.
8. provision for jacking, lifting, and towing.
9. diagram and rating nameplate.

2.9.1.3 Integral Outgoing Section

Integral outgoing section shall be of the metal-enclosed switchgear type. Each circuit breaker and auxiliary compartment shall have a suitable metal or laminated plastic nameplate with white cut letters at least 1/4 inch high on contrasting backgrounds identifying the breaker unit and/or circuit number.

- a. Busway Throat Compartment Type: Outgoing section shall consist of an enclosure containing metering devices on the main secondary circuit and connections from transformer terminals to suitable busway throats provided for connections to busway installations entering as shown. Connection to porcelain bushings shall be made with flexible jumpers.
- b. Metal-Enclosed Switchgear Type: Outgoing section shall be of the metal-enclosed drawout circuit breaker type, in accordance with IEEE C37.20.1. Low-voltage power circuit breakers shall comply with the requirements of paragraph METERING AND PROTECTIVE DEVICES.
- c. Metering: The main secondary bus of each outgoing section assembly shall include a watthour demand meter with the necessary instrument transformers, and VT and CT test blocks. Metering shall be as specified in paragraph METERING AND PROTECTIVE DEVICES.
- d. Ground Fault Protection: Ground fault protection shall be provided utilizing sensors of the zero-sequence type or by the residual connection of phase and neutral current sensors. Ground fault settings shall be as determined by the coordination study.

2.9.1.4 Nonintegral (Cable Compartment) Outgoing Section

A cable compartment shall be provided on the transformer for cable connections as shown. Clamp type terminations for cables entering from below shall be provided for connection to the transformer bushings. Clamp type cable terminations, suitable for copper conductors, shall be provided to match circuit breakers.

2.9.2 Pad-Mounted Transformers

Pad-mounted transformers shall comply with IEEE C57.12.26 and shall be of

REPAIR AIRFIELD RAMP LIGHTS

the radial type. Pad-mounted transformer stations shall be assembled and coordinated by one manufacturer and each transformer station shall be shipped as a complete unit so that field installation requirements are limited to mounting each unit on a concrete pad and connecting it to primary and secondary lines. Stainless steel pins and hinges shall be provided. Barriers shall be provided between high- and low-voltage compartments. High-voltage compartment doors shall be interlocked with low-voltage compartment doors to prevent access to any high-voltage section unless its associated low-voltage section door has first been opened. Compartments shall be sized to meet the specific dimensional requirements of IEEE C57.12.26. Pentahead locking bolts shall be provided with provisions for a padlock.

2.9.2.1 High-Voltage Compartments

The high-voltage compartment shall be dead-front construction. Primary switching and protective devices shall include loadbreak switching, oil-immersed, current-limiting, bayonet-type fuses, medium-voltage separable loadbreak connectors, universal bushing wells and inserts or integral one piece bushings and surge arresters. Fuses shall comply with the requirements of paragraph METERING AND PROTECTIVE DEVICES. The switch shall be mounted inside transformer tank with switch operating handle located in high-voltage compartment and equipped with metal loop for hook stick operation. Fuses shall be interlocked with switches so that fuses can be removed only when the associated switch is in the "OPEN" position. Adjacent to medium-voltage cable connections, a nameplate or equivalent stenciled inscription shall be provided inscribed "DO NOT OPEN CABLE CONNECTORS UNLESS SWITCH IS OPEN." Surge arresters shall be fully insulated and configured to terminate on the same bushing as the primary cable by means of a loadbreak, feed-through bushing insert.

2.9.2.2 Load-Break Switch

a. Radial-feed oil-immersed type rated at 25 kV, 125 kV BIL, with a continuous current rating and load-break rating of 200 ampere, and a make-and-latch rating of 10,000 rms amperes symmetrical. Locate the switch handle in the high-voltage compartment.

2.9.2.3 Transformer Tank Sections

Transformers shall comply with IEEE C57.12.00 and IEEE C57.12.21 and shall be of the less-flammable, liquid-insulated type with dimethyl silicone liquid. Transformers shall be suitable for outdoor use and shall have 2 separate windings per phase. Standard NEMA primary taps shall be provided. Where primary taps are not specified, 4, 2-1/2 percent rated kVA high-voltage taps shall be provided 2 above and 2 below rated, primary voltage. Operating handles for primary tap changers for de-energized operation shall be located within high-voltage compartments, externally to transformer tanks. Adjacent to the tap changer operating handle, a nameplate or equivalent stenciled inscription shall be provided and inscribed "DO NOT OPERATE UNDER LOAD." Transformer ratings at 60 Hz shall be as follows:

- a. Three-phase capacity.....as indicated.
- b. Impedance.....5.75%.
- c. Temperature Rise.....55/65 degrees C.

REPAIR AIRFIELD RAMP LIGHTS

- d. High-voltage winding.....22k volts.
- f. Low-voltage winding.....480 volts.

2.9.2.4 Low-Voltage Cable Compartments

Neutrals shall be provided with fully-insulated bushings. Clamp type cable terminations, suitable for copper conductors entering from below, shall be provided as necessary.

2.9.2.5 Accessories

High-voltage warning signs shall be permanently attached to each side of transformer stations. Voltage warning signs shall comply with IEEE C2. Copper-faced steel or stainless steel ground connection pads shall be provided in both the high- and low-voltage compartments. Dial-type thermometer, liquid-level gauge, and drain valve with built-in sampling device shall be provided for each transformer station. Insulated-bushing-type parking stands shall be provided adjacent to each separable load-break elbow to provide for cable isolation during sectionalizing operations.

2.9.3 Pad-Mounted, Metal-Enclosed, Switchgear

The switchgear shall be configured with 2 incoming compartments for loop-feed arrangement SF6-insulated, load-interrupter switches, as indicated. The outgoing compartments shall be provided with fused disconnects or non-reclosing vacuum-type interrupters or circuit breakers, as indicated.

2.9.3.1 Ratings at 60 Hz shall be:

- a. Nominal voltage (kV).....22 kV.
- b. Rated maximum voltage (kV).....25 kV.
- c. Rated continuous current (A).....600A.
- d. Maximum symmetrical interrupting capacity (kA).....as calculated.
- e. Maximum asymmetrical interrupting capacity (kA).....as calculated.
- f. Three-second short-time current-carrying capacity (kA)as calculated.
- g. BIL (kV).....125 kV.

2.9.3.2 Operators, Devices, and Controls

Operators and controls shall be provided for the switchgear as follows:

- a. Switches shall be provided with a manual, handle-type operator or a push-button mechanical spring tripping mechanism, utilizing a stored-energy (spring-driven) mechanism to simultaneously open or close all phases. The switchgear shall be configured so that the switch actuator is padlockable, but may be accessed without opening the switch compartment doors.
- b. Fused disconnects shall be hook-stick operated.

REPAIR AIRFIELD RAMP LIGHTS

c. Switches shall be provided with an automatic switch operator configured for local and remote opening and closing. An actuator charging motor shall be provide which operates at 120 V ac. Switches shall be provided with remote telemetry units (RTUs) for remote operation and integration with supervisory, control, and data acquisition systems. Systems, components, and equipment shall conform to the requirements and recommendations of IEEE C37.1.

d. Vacuum type interrupters shall be provided with an electronic controller for trip initiation. Manual trip initiation shall be provided by a push button or switch. Automatic trip shall be initiated by detection of excessive current. The electronic controller shall provide trip current selection capability according to present time-current response curves, as indicated. Each interrupter shall be provided with a 3 phase, gang-operated handle mechanism for trip and reset.

2.9.3.3 Enclosures

Switchgear enclosures shall be of freestanding, self-supporting construction provided with separate incoming and outgoing compartments configured for bottom cable entry. Enclosures shall be of deadfront construction, provided with a hinged door for access to each compartment, and conform to the requirements of IEEE C57.12.28 and IEEE C37.20.3, Category A.

2.9.4 Cable Terminating Cabinets

Cable terminating cabinets shall be hook-stick operable, deadfront construction conforming to the requirements of IEEE C37.20.3, Category A. Cabinets shall be provided with with 600 A. dead-break junctions and elbow-type separable dead-break connectors, cable parking stands, and grounding lugs. The cable terminating equipments shall conform to IEEE Std 386.

Ratings at 60 Hz shall be:

- a. Nominal voltage (kV).....22.
- b. Rated maximum voltage (kV).....25.
- c. Rated continuous current (A).....600.
- e. BIL (kV).....125.

2.10 METERING AND PROTECTIVE DEVICES

2.10.1 Circuit Breakers, Low-Voltage

2.10.1.1 Low-Voltage Power Circuit Breakers

a. Construction. Low-voltage power circuit breakers shall conform to IEEE C37.13 and IEEE C37.16, and shall be three-pole, single-throw, stored energy, electrically operated, with drawout mounting. Solid-state trip elements which require no external power connections shall be provided. Circuit breakers shall have an open/close contact indicator, primary disconnect devices, and a mechanical interlock to prevent making or breaking contact of primary disconnections when the circuit breaker is closed. Control voltage shall be 120 V ac. The

REPAIR AIRFIELD RAMP LIGHTS

circuit breaker enclosure shall be suitable for its intended location.

b. Ratings. Voltage ratings shall be not less than the applicable circuit voltage. Circuit breakers shall be rated for 100 percent continuous duty and shall have trip current ratings and frame sizes as shown. Nominal voltage ratings, maximum continuous-current ratings, and maximum short-circuit interrupting ratings shall be in accordance with IEEE C37.16. Tripping features shall be as follows:

1. Long-time current pick-up, adjustable from 50 percent to 100 percent of sensor current rating.
2. Adjustable long-time delay.
3. Short-time current pick-up, adjustable from 1.5 to 9 times long-time current setting.
4. Adjustable short-time delay.
5. Instantaneous current pick-up, adjustable from 1.5 to 9 times long-time current setting.
6. Ground-fault pick-up, adjustable from 20 percent to 60 percent of sensor rating, but in no case greater than 1200 amperes. Sensing of ground-fault current at the main bonding jumper or ground strap shall not be permitted.
7. Adjustable ground-fault delay.
8. Overload, short-circuit, ground-fault trip indicators shall be provided.

2.10.1.2 Molded-Case Circuit Breakers

NEMA AB 1 and UL 489.

2.10.2 Fuses, Medium-Voltage, Including Current-Limiting

2.10.2.1 Construction

Units shall be suitable for outdoor use. Fuses shall have integral blown-fuse indicators. All ratings shall be clearly visible.

2.10.2.2 Ratings

Current-limiting power fuses shall have ratings in accordance with IEEE C37.46 and as indicated:

2.10.2.3 E-Rated, Current-Limiting Power Fuses

E-rated, current-limiting, power fuses shall conform to IEEE C37.46.

2.10.2.4 C-Rated, Current-Limiting Power Fuses

C-rated, current-limiting power fuses shall open in 1000 seconds at currents between 170 and 240 percent of the C rating.

REPAIR AIRFIELD RAMP LIGHTS

2.10.3 Fuses, Low-Voltage, Including Current-Limiting

Low-voltage fuses shall conform to NEMA FU 1. Time delay and nontime delay options shall be as shown. Equipment provided under this contract shall be provided with a complete set of properly rated fuses when the equipment manufacturer utilizes fuses in the manufacture of the equipment, or if current-limiting fuses are required to be installed to limit the ampere-interrupting capacity of circuit breakers or equipment to less than the maximum available fault current at the location of the equipment to be installed. Fuses shall have a voltage rating of not less than the phase-to-phase circuit voltage, and shall have the time-current characteristics required for effective power system coordination.

2.10.3.1 Cartridge Fuses

Cartridge fuses, current-limiting type, Class RK5 shall have tested interrupting capacity not less than 100,000 amperes. Fuse holders shall be the type that will reject Class H fuses.

- a. Class R fuses shall conform to UL 198M.

2.10.3.2 Transformer Circuit Fuses

Transformer circuit fuses shall be Class RK1 or RK5, current-limiting, time-delay with 200,000 amperes interrupting capacity.

2.10.4 Instrument Transformers

2.10.4.1 General

Instrument transformers shall comply with NEMA C12.11 and IEEE C57.13. Instrument transformers shall be configured for mounting in/on the device to which they are applied. Polarity marks on instrument transformers shall be visually evident and shown on drawings.

2.10.4.2 Current Transformers

Unless otherwise indicated, bar, wound, or window-type transformers are acceptable; and except for window-type units installed over insulated buses, transformers shall have a BIL rating consistent with the rated BIL of the associated switchgear or electric power apparatus bushings, buses or conductors. Current transformers shall have the indicated ratios. The continuous thermal-current rating factor shall not be less than 2.0. Other thermal and mechanical ratings of current transformers and their primary leads shall be coordinated with the design of the circuit breaker and shall be not less than the momentary rating of the associated circuit breaker. Circuit protectors shall be provided across secondary leads of the current transformers to prevent the accident open-circuiting of the transformers while energized. Each terminal of each current transformer shall be connected to a short-circuiting terminal block in the circuit interrupting mechanism cabinet, power transformer terminal cabinet, and in the associated instrument and relay cabinets.

2.10.4.3 Current Transformers for Power Transformers

Single-ratio bushing type current transformers shall be provided internally around power transformer bushings as shown. Single-ratio units shall have a minimum relaying accuracy class of 0.3B-0.5.

REPAIR AIRFIELD RAMP LIGHTS

2.10.4.4 Current Transformers for Metal-Enclosed Switchgear

Single-ratio units, used for metering and relaying, shall have a metering accuracy class rating of 0.3B-0.5.

2.10.4.5 Current Transformers for Kwh and Demand Metering (Low-Voltage)

Current transformers shall conform to IEEE C57.13. Provide current transformers with a metering accuracy Class of 0.3 through B-0.5, with a minimum RF of 3 at 30 degrees C, with 600-volt insulations, and 10 kV BIL. Provide butyl-molded, window-type current transformers mounted in the current transformer cabinet.

2.10.4.6 Voltage Transformers

Voltage transformers shall have indicated ratios. Units shall have an accuracy class rating of 0.3. Voltage transformers shall be of the drawout type having current-limiting fuses in both primary and secondary circuits. Mechanical interlocks shall prevent removal of fuses, unless the associated voltage transformer is in a drawout position. Voltage transformer compartments shall have hinged doors.

2.10.5 Watthour Meters

Watthour meters shall conform to NEMA C12.10, except numbered terminal wiring sequence and case size may be the manufacturer's standard. Watthour meters shall be of the socket mounted outdoor type having a 15 minute, cumulative form, demand register meeting NEMA C12.4 and provided with not less than 2-1/2 stators. Watthour demand meters shall have factory-installed electronic pulse initiators. Pulse initiators shall be solid-state devices incorporating light-emitting diodes, phototransistors, and power transistors, except that mercury-wetted output contacts are acceptable. Initiators shall be totally contained within watthour demand meter enclosures, shall be capable of operating up to speeds of 500 pulses per minute with no false pulses, and shall require no field adjustments. Initiators shall be calibrated for a pulse rate output of 1 pulse per 1/4 disc revolution of the associated meter and shall be compatible with the indicated equipment. Coordinate with existing system at Langley Air Force Base.

2.10.6 Protective Relaying

2.10.6.1 General

Solid-state protective relays shall be provided as shown and shall be of a type specifically designed for use on power switchgear or associated electric power apparatus. Protective relays shall conform to IEEE C37.90. Relays and auxiliaries shall be suitable for operation with the instrument transformer ratios and connections provided.

2.10.6.2 Construction

Relays shall be dustproof and moisture resistant. Necessary test devices shall be incorporated within each relay and shall provide a means for testing either from an external source of electric power or from associated instrument transformers. Each relay shall be provided with an operation indicator and an external target reset device. Relays shall have necessary auxiliaries for proper operation. Relays and auxiliaries shall be suitable for operation with the instrument transformer ratios and connections

REPAIR AIRFIELD RAMP LIGHTS

provided.

2.10.6.3 Ratings

Relays shall be the manufacturer's standard items of equipment with appropriate ranges for time dial, tap, and other settings. Relay device numbers shall correspond to the function names and descriptions of IEEE C37.2.

2.11 SURGE ARRESTERS

Surge arresters shall comply with NEMA LA 1, and IEEE C62.11 and shall be provided where indicated. Arresters shall be distribution class, rated as shown. Arresters for use at elevations in excess of 6000 feet above mean sea level shall be specifically rated for that purpose. Arresters shall be equipped with mounting brackets suitable for the indicated installations. Arresters shall be of the valve or metal-oxide varistor or combination valve-metal-oxide varistor type.

2.12 GROUNDING AND BONDING

2.12.1 Driven Ground Rods

Ground rods shall be copper-clad steel conforming to UL 467 5/8 inch in diameter by 10 feet in length. Sectional type rods may be used.

2.12.2 Grounding Conductors

Grounding conductors shall be bare, except where installed in conduit with associated phase conductors. Insulated conductors shall be of the same material as phase conductors and green color-coded, except that conductors shall be rated no more than 600 volts. Bare conductors shall be ASTM B 8 soft-drawn unless otherwise indicated. Aluminum is not acceptable.

2.13 CONCRETE AND REINFORCEMENT

Concrete work shall have minimum 3000 psi compressive strength and conform to the requirements of Section 03 30 53 MISCELLANEOUS CAST-IN-PLACE CONCRETE. Concrete reinforcing shall be as indicated.

2.14 PADLOCKS

Padlocks shall be provided.

2.15 CABLE FIREPROOFING SYSTEMS

Cable fireproofing systems shall be listed in FM P7825a as a fire-protective coating or tape approved for grouped electrical conductors and shall be suitable for application on the type of medium-voltage cables provided. After being fully cured, materials shall be suitable for use where exposed to oil, water, gases, salt water, sewage, and fungus and shall not damage cable jackets or insulation. Asbestos materials are not acceptable.

2.15.1 Fireproof Coating

Cable fireproofing coatings shall be compounded of water-based thermoplastic resins, flame-retardant chemicals, and inorganic noncombustible fibers and shall be suitable for the application methods

REPAIR AIRFIELD RAMP LIGHTS

used. Coatings applied on bundled cables shall have a derating factor of less than 5 percent, and a dielectric strength of 95 volts per mil minimum after curing.

2.15.2 Fireproofing Tape

Fireproofing tape shall be at least 2 inches wide and shall be a flexible, conformable, polymeric, elastomer tape designed specifically for fireproofing cables.

2.15.3 Plastic Tape

Preapplication plastic tape shall be pressure sensitive, 10 mil thick, conforming to UL 510.

2.16 LIQUID DIELECTRICS

Liquid dielectrics for transformers, capacitors, reclosers, and other liquid-filled electrical equipment shall be non-polychlorinated biphenyl (PCB)less-flammable liquid as specified. Nonflammable fluids shall not be used. Tetrachloroethylene (perchloroethylene) and 1, 2, 4 trichlorobenzene fluids shall not be used. Liquid dielectrics in retrofitted equipment shall be certified by the manufacturer as having less than 2 parts per million (ppm) PCB content. In lieu of the manufacturer's certification, the Contractor may submit a test sample of the dielectric in accordance with ASTM D 923 and have tests performed in accordance with ASTM D 4059 at a testing facility approved by the Contracting Officer. Equipment with test results indicating PCB level exceeding 2 ppm shall be replaced.

2.17 FACTORY TESTS

Factory tests shall be performed, as follows, in accordance with the applicable publications and with other requirements of these specifications. The Contracting Officer shall be notified at least 14 days before the equipment is ready for testing. The Contracting Officer reserves the right to witness the tests.

a. Transformers: Manufacturer's standard routine tests in accordance with IEEE C57.12.00.

b. High-Voltage Air Switches: Manufacturer's standard tests in accordance with IEEE C37.34 and IEEE C37.41.

c. Relaying Current Transformers: Manufacturer's standard tests in accordance with IEEE C57.13.

d. Instrument Current Transformers: Manufacturer's standard tests in accordance with IEEE C57.13.

e. Factory Preformed Terminations: Wet withstand voltage tests in accordance with IEEE Std 48 for the next higher BIL level.

f. Outdoor Switchgear: Manufacturer's standard tests in accordance with IEEE C37.20.1, IEEE C37.20.2, and IEEE C37.20.3.

g. Electrical Power Insulators: Manufacturer's standard tests in accordance with NEMA C29.1.

REPAIR AIRFIELD RAMP LIGHTS

2.18 COORDINATED POWER SYSTEM PROTECTION

Analyses shall be prepared to demonstrate that the equipment selected and system constructed meet the contract requirements for equipment ratings, coordination, and protection. They shall include a load flow analysis, a fault current analysis, and a protective device coordination study. The studies shall be performed by a registered professional engineer with demonstrated experience in power system coordination in the last three years. Provide a list of references complete with points of contact, addresses and telephone numbers. The selection of the engineer is subject to the approval of the Contracting Officer.

2.18.1 Scope of Analyses

The fault current analysis, and protective device coordination study shall begin at: the 22 kV source bus and extend down to each high mast pole control enclosure.

2.18.2 Determination of Facts

The time-current characteristics, features, and nameplate data for each existing protective device shall be determined and documented. Coordinate with the LAFB for fault current availability at the site.

2.18.3 Single Line Diagram

A single line diagram shall be prepared to show the electrical system buses, devices, transformation points, and all sources of fault current (including generator and motor contributions). A fault-impedance diagram or a computer analysis diagram may be provided. Each bus, device or transformation point shall have a unique identifier. If a fault-impedance diagram is provided, impedance data shall be shown. Locations of switches, breakers, and circuit interrupting devices shall be shown on the diagram together with available fault data, and the device interrupting rating.

2.18.4 Fault Current Analysis

2.18.4.1 Method

The fault current analysis shall be performed in accordance with methods described in IEEE Std 242, and IEEE Std 399.

2.18.4.2 Data

Actual data shall be utilized in fault calculations. Bus characteristics and transformer impedances shall be those proposed. Data shall be documented in the report.

2.18.5 Coordination Study

The study shall demonstrate that the maximum possible degree of selectivity has been obtained between devices specified, consistent with protection of equipment and conductors from damage from overloads and fault conditions. The study shall include a description of the coordination of the protective devices in this project. Provide a written narrative that describes: which devices may operate in the event of a fault at each bus; the logic used to arrive at device ratings and settings; situations where system coordination is not achievable due to device limitations (an analysis of any device curves which overlap); coordination between upstream and downstream

REPAIR AIRFIELD RAMP LIGHTS

devices; and any relay settings. Recommendations to improve or enhance system reliability, and detail where such changes would involve additions or modifications to the contract and cost changes (addition or reduction) shall be provided. Composite coordination plots shall be provided on log-log graph paper.

2.18.6 Study Report

- a. The report shall include a narrative describing: the analyses performed; the bases and methods used; and the desired method of coordinated protection of the power system.
- b. The study shall include descriptive and technical data for existing devices and new protective devices proposed. The data shall include manufacturers published data, nameplate data, and definition of the fixed or adjustable features of the existing or new protective devices.
- c. The report shall document utility company data including system voltages, fault MVA, system X/R ratio, time-current characteristics curves, current transformer ratios, and relay device numbers and settings; and existing power system data including time-current characteristic curves and protective device ratings and settings.
- d. The report shall contain fully coordinated composite time-current characteristic curves for each bus in the system, as required to ensure coordinated power system protection between protective devices or equipment. The report shall include recommended ratings and settings of all protective devices in tabulated form.
- e. The report shall provide the calculation performed for the analyses, including computer analysis programs utilized. The name of the software package, developer, and version number shall be provided.

PART 3 EXECUTION

3.1 EXAMINATION

After becoming familiar with details of the work, verify dimensions in the field, and advise the Contracting Officer of any discrepancy before performing any work.

3.2 INSTALLATION REQUIREMENTS

Equipment and devices shall be installed and energized in accordance with the manufacturer's published instructions. Steel conduits installed underground shall be installed and protected from corrosion in conformance with the requirements of Section 33 70 02.00 10 ELECTRICAL DISTRIBUTION SYSTEM, UNDERGROUND. Except as covered herein, excavation, trenching, and backfilling shall conform to the requirements of Section 31 00 00 EARTHWORK. Concrete work shall have minimum 3000 psi compressive strength and conform to the requirements of Section 03 30 53 MISCELLANEOUS CAST-IN-PLACE CONCRETE.

3.2.1 Conformance to Codes

The installation shall comply with the requirements and recommendations of NFPA 70 and IEEE C2 as applicable.

REPAIR AIRFIELD RAMP LIGHTS

3.2.2 Disposal of Liquid Dielectrics

PCB-contaminated dielectrics must be marked as PCB and transported to and incinerated by an approved EPA waste disposal facility. Furnish certification of proper disposal. Contaminated dielectrics shall not be diluted to lower the contamination level.

3.3 CABLE AND BUSWAY INSTALLATION

Obtain from the manufacturer an installation manual or set of instructions which addresses such aspects as cable construction, insulation type, cable diameter, bending radius, cable temperature, lubricants, coefficient of friction, conduit cleaning, storage procedures, moisture seals, testing for and purging moisture, etc. And then perform pulling calculations and prepare a pulling plan which shall be submitted along with the manufacturers instructions in accordance with SUBMITTALS.

3.3.1 Cable Installation Plan and Procedure

Cable shall be installed strictly in accordance with the cable manufacturer's recommendations. Each circuit shall be identified by means of a fiber, laminated plastic, or non-ferrous metal tags, or approved equal, in each manhole, handhole, junction box, and each terminal. Each tag shall contain the following information; cable type, conductor size, circuit number, circuit voltage, cable destination and phase identification.

3.3.1.1 Cable Inspection

The cable reel shall be inspected for correct storage positions, signs of physical damage, and broken end seals. If end seal is broken, moisture shall be removed from cable in accordance with the cable manufacturer's recommendations.

3.3.1.2 Duct Cleaning

Duct shall be cleaned with an assembly that consists of a flexible mandrel (manufacturers standard product in lengths recommended for the specific size and type of duct) that is 1/4 inch less than inside diameter of duct, 2 wire brushes, and a rag. The cleaning assembly shall be pulled through conduit a minimum of 2 times or until less than a volume of 8 cubic inches of debris is expelled from the duct.

3.3.1.3 Duct Lubrication

The cable lubricant shall be compatible with the cable jacket for cable that is being installed. Application of lubricant shall be in accordance with lubricant manufacturer's recommendations.

3.3.1.4 Cable Installation

Provide a cable feeding truck and a cable pulling winch as required. Provide a pulling grip or pulling eye in accordance with cable manufacturer's recommendations. The pulling grip or pulling eye apparatus shall be attached to polypropylene or manila rope followed by lubricant front end packs and then by power cables. A dynamometer shall be used to monitor pulling tension. Pulling tension shall not exceed cable manufacturer's recommendations. Do not allow cables to cross over while cables are being fed into duct. For cable installation in cold weather, cables shall be kept at 50 degrees F temperature for at least 24 hours

REPAIR AIRFIELD RAMP LIGHTS

before installation.

3.3.1.5 Cable Installation Plan

Submit a cable installation plan for all cable pulls in accordance with the detail drawings portion of paragraph SUBMITTALS. Cable installation plan shall include:

- a. Site layout drawing with cable pulls identified in numeric order of expected pulling sequence and direction of cable pull.
- b. List of cable installation equipment.
- c. Lubricant manufacturer's application instructions.
- d. Procedure for resealing cable ends to prevent moisture from entering cable.
- e. Cable pulling tension calculations of all cable pulls.
- f. Cable percentage conduit fill.
- g. Cable sidewall thrust pressure.
- h. Cable minimum bend radius and minimum diameter of pulling wheels used.
- i. Cable jam ratio.
- j. Maximum allowable pulling tension on each different type and size of conductor.
- k. Maximum allowable pulling tension on pulling device.

3.3.2 Duct Line

Cables shall be installed in duct lines where indicated. Cable splices in low-voltage cables shall be made in manholes and handholes only. Cable joints in medium-voltage cables shall be made in manholes or approved pullboxes only. Neutral and grounding conductors shall be installed in the same duct with their associated phase conductors.

3.3.3 Electric Manholes

Cables shall be routed around the interior walls and securely supported from walls on cables racks. Cable routing shall minimize cable crossover, provide access space for maintenance and installation of additional cables, and maintain cable separation in accordance with IEEE C2.

3.3.4 Busway Installation

Busways penetrating walls shall have wall flanges installed on both surfaces of walls. Wall openings shall be approximately 1/4 inch larger than the busway on each of the 4 busway sides, and openings shall be sealed with a suitable compound. Fire barriers shall be provided when penetrating fire rated walls. Fire barriers shall have a rating equal to the fire wall rating. A weather barrier shall be used when a busway penetrates an exterior wall. Busways shall be supported at intervals not exceeding 10 feet and shall be braced to prevent lateral movement.

REPAIR AIRFIELD RAMP LIGHTS

3.4 CABLE JOINTS

Medium-voltage cable joints shall be made by qualified cable splicers only. Qualifications of cable splicers shall be submitted in accordance with paragraph SUBMITTALS. Shields shall be applied as required to continue the shielding system through each entire cable joint. Shields may be integrally molded parts of preformed joints. Shields shall be grounded at each joint or in accordance with manufacturer's recommended practice. Cable joints shall provide insulation and jacket equivalent to that of the associated cable. Armored cable joints shall be enclosed in compound-filled, cast-iron or alloy, splice boxes equipped with stuffing boxes and armor clamps of a suitable type and size for the cable being installed.

3.5 FIREPROOFING

Fire-stops shall be installed in each conduit entering or leaving a manhole.

3.5.1 Tape Method

Before application of fireproofing tape, plastic tape wrapping shall be applied over exposed metallic items such as the cable ground wire, metallic outer covering, or armor to minimize the possibility of corrosion from the fireproofing materials and moisture. Before applying fireproofing tape, irregularities of cables, such as at cable joints, shall be evened out with insulation putty. A flexible conformable polymeric elastomer fireproof tape shall be wrapped tightly around each cable spirally in 1/2 lapped wrapping or in 2 butt-jointed wrappings with the second wrapping covering the joints of the first.

3.5.2 Sprayable Method

Manholes shall be power ventilated until coatings are dry and dewatered and the coatings are cured. Ventilation requirements shall be in accordance with the manufacturer's instruction, but not less than 10 air changes per hour shall be provided. Cable coatings shall be applied by spray, brush, or glove to a wet film thickness that reduces to the dry film thickness approved for fireproofing by FM P7825a. Application methods and necessary safety precautions shall be in accordance with the manufacturers instructions. After application, cable coatings shall be dry to the touch in 1 to 2 hours and fully cured in 48 hours, except where the manufacturer has stated that because of unusual humidity or temperature, longer periods may be necessary.

3.6 DUCT LINES

3.6.1 Requirements

Numbers and sizes of ducts shall be as indicated. Duct lines shall be laid with a minimum slope of 4 inches per 100 feet. Depending on the contour of the finished grade, the high-point may be at a terminal, a manhole, a handhole, or between manholes or handholes. Short-radius manufactured 90-degree duct bends may be used only for pole or equipment risers, unless specifically indicated as acceptable. The minimum manufactured bend radius shall be 18 inches for ducts of less than 3 inch diameter, and 36 inches for ducts 3 inches or greater in diameter. Otherwise, long sweep bends having a minimum radius of 25 feet shall be used for a change of direction of more than 5 degrees, either horizontally or vertically. Both curved and

REPAIR AIRFIELD RAMP LIGHTS

straight sections may be used to form long sweep bends, but the maximum curve used shall be 30 degrees and manufactured bends shall be used. Ducts shall be provided with end bells whenever duct lines terminate in manholes or handholes.

3.6.2 Treatment

Ducts shall be kept clean of concrete, dirt, or foreign substances during construction. Field cuts requiring tapers shall be made with proper tools and match factory tapers. A coupling recommended by the duct manufacturer shall be used whenever an existing duct is connected to a duct of different material or shape. Ducts shall be stored to avoid warping and deterioration with ends sufficiently plugged to prevent entry of any water or solid substances. Ducts shall be thoroughly cleaned before being laid. Plastic ducts shall be stored on a flat surface and protected from the direct rays of the sun.

3.6.3 Concrete Encasement

Ducts requiring concrete encasements shall comply with NFPA 70, except that electrical duct bank configurations for ducts 6 inches in diameter shall be determined by calculation and as shown on the drawings. The separation between adjacent electric power and communication ducts shall conform to IEEE C2. Duct line encasements shall be monolithic construction. Where a connection is made to a previously poured encasement, the new encasement shall be well bonded or doweled to the existing encasement. Submit proposed bonding method for approval in accordance with the detail drawing portion of paragraph SUBMITTALS. At any point, except railroad and airfield crossings, tops of concrete encasements shall be not less than the cover requirements listed in NFPA 70. At railroad and airfield crossings, duct lines shall be encased with concrete and reinforced as indicated to withstand specified surface loadings. Tops of concrete encasements shall be not less than 5 feet below tops of rails or airfield paving unless otherwise indicated. Where ducts are jacked under existing pavement, rigid steel conduit will be installed because of its strength. To protect the corrosion-resistant conduit coating, predrilling or installing conduit inside a larger iron pipe sleeve (jack-and-sleeve) is required. For crossings of existing railroads and airfield pavements greater than 50 feet in length, the predrilling method or the jack-and-sleeve method will be used. Separators or spacing blocks shall be made of steel, concrete, plastic, or a combination of these materials placed not farther apart than 4 feet on centers. Ducts shall be securely anchored to prevent movement during the placement of concrete and joints shall be staggered at least 6 inches vertically.

3.6.4 Installation of Couplings

Joints in each type of duct shall be made up in accordance with the manufacturer's recommendations for the particular type of duct and coupling selected and as approved.

3.6.4.1 Bituminized-Fiber Ducts

Bituminized-fiber ducts shall be used to interface with existing bituminized-fiber duct. To ensure a watertight joint, tapered ends or joints of the same material as the ducts shall be swabbed with bituminous or joint-sealing compound before couplings are applied. Plastic or nonmetallic couplings shall be tightly driven onto unswabbed ducts. Due to the brittleness of plastic couplings at low temperatures, such couplings

REPAIR AIRFIELD RAMP LIGHTS

shall not be installed when temperatures are below 0 degrees F. Couplings shall be warmed in hot water or by another approved method when installed at temperatures below 32 degrees F.

3.6.4.2 Plastic Duct

Duct joints shall be made by brushing a plastic solvent cement on insides of plastic coupling fittings and on outsides of duct ends. Each duct and fitting shall then be slipped together with a quick 1/4-turn twist to set the joint tightly.

3.6.5 Duct Line Markers

Duct line markers shall be provided at the ends of long duct line stubouts or for other ducts whose locations are indeterminate because of duct curvature or terminations at completely below-grade structures. In addition to markers, a 5 mil brightly colored plastic tape, not less than 3 inches in width and suitably inscribed at not more than 10 feet on centers with a continuous metallic backing and a corrosion-resistant 1 mil metallic foil core to permit easy location of the duct line, shall be placed approximately 12 inches below finished grade levels of such lines.

3.7 MANHOLES, HANDHOLES, AND PULLBOXES

3.7.1 General

Manholes shall be constructed approximately where shown. The exact location of each manhole shall be determined after careful consideration has been given to the location of other utilities, grading, and paving. The location of each manhole shall be approved by the Contracting Officer before construction of the manhole is started. Manholes shall be the type noted on the drawings and shall be constructed in accordance with the applicable details as indicated. Top, walls, and bottom shall consist of reinforced concrete. Walls and bottom shall be of monolithic concrete construction. The Contractor may, as an option, utilize monolithically constructed precast-concrete manholes having the required strength and inside dimensions as required by the drawings or specifications. In paved areas, frames and covers for manhole and handhole entrances in vehicular traffic areas shall be flush with the finished surface of the paving. In unpaved areas, the top of manhole covers shall be approximately 1/2 inch above the finished grade. Where existing grades that are higher than finished grades are encountered, concrete assemblies designed for the purpose shall be installed to elevate temporarily the manhole cover to existing grade level. All duct lines entering manholes must be installed on compact soil or otherwise supported when entering a manhole to prevent shear stress on the duct at the point of entrance to the manhole. Duct lines entering cast-in-place concrete manholes shall be cast in-place with the manhole. Duct lines entering precast concrete manholes through a precast knockout penetration shall be grouted tight with a portland cement mortar. PVC duct lines entering precast manholes through a PVC endbell shall be solvent welded to the endbell. A cast metal grille-type sump frame and cover shall be installed over the manhole sump. A cable-pulling iron shall be installed in the wall opposite each duct line entrance.

3.7.2 Electric Manholes

Cables shall be securely supported from walls by hot-dip galvanized cable racks with a plastic coating over the galvanizing and equipped with adjustable hooks and insulators. The number of cable racks indicated shall

REPAIR AIRFIELD RAMP LIGHTS

be installed in each manhole and not less than 2 spare hooks shall be installed on each cable rack. Insulators shall be made of high-glazed porcelain. Insulators will not be required on spare hooks.

3.7.3 Communications Manholes

The number of hot-dip galvanized cable racks with a plastic coating over the galvanizing indicated shall be installed in each telephone manhole. Each cable rack shall be provided with 2 cable hooks. Cables for the telephone and communication systems will be installed by others.

3.7.4 Handholes

Handholes shall be located approximately as shown. Handholes shall be of the type noted on the drawings and shall be constructed in accordance with the details shown.

3.7.5 Pullboxes

Pullbox tops shall be flush with sidewalks or curbs or placed 1/2 inch above surrounding grades when remote from curbed roadways or sidewalks. Covers shall be marked "Low-Voltage" and provided with 2 lifting eyes and 2 hold-down bolts. Each box shall have a suitable opening for a ground rod. Conduit, cable, ground rod entrances, and unused openings shall be sealed with mortar.

3.7.6 Ground Rods

A ground rod shall be installed at the manholes, handholes and pullboxes. Ground rods shall be driven into the earth before the manhole floor is poured so that approximately 4 inches of the ground rod will extend above the manhole floor. When precast concrete manholes are used, the top of the ground rod may be below the manhole floor and a No. 1/0 AWG ground conductor brought into the manhole through a watertight sleeve in the manhole wall.

3.8 PAD-MOUNTED EQUIPMENT INSTALLATION

Pad-mounted equipment, shall be installed on concrete pads in accordance with the manufacturer's published, standard installation drawings and procedures, except that they shall be modified to meet the requirements of this document. Units shall be installed so that they do not damage equipment or scratch painted or coated surfaces. After installation, surfaces shall be inspected and scratches touched up with a paint or coating provided by the manufacturer especially for this purpose.

3.8.1 Concrete Pads

3.8.1.1 Construction

Concrete pads for pad-mounted electrical equipment may be either pre-fabricated or poured-in-place. Pads shall be constructed as indicated, except that exact pad dimensions and mounting details are equipment specific and are the responsibility of the Contractor. Tops of concrete pads shall be level and shall project 4 inches above finished paving or grade and sloped to drain. Edges of concrete pads shall have 3/4 inch chamfer. Conduits for primary, secondary, and grounding conductors shall be set in place prior to placement of concrete pads. Where grounding electrode conductors are installed through concrete pads, PVC conduit

REPAIR AIRFIELD RAMP LIGHTS

sleeves shall be installed through the concrete to provide physical protection. To facilitate cable installation and termination, the concrete pad shall be provided with a rectangular hole below the primary and secondary compartments, sized in accordance with the manufacturer's recommended dimensions. Upon completion of equipment installation the rectangular hole shall be filled with masonry grout.

3.8.1.2 Concrete and Reinforcement

Concrete work shall have minimum 3000 psi compressive strength and conform to the requirements of Section 03 30 53 MISCELLANEOUS CAST-IN-PLACE CONCRETE.

3.8.1.3 Sealing

When the installation is complete, seal all conduit and other entries into the equipment enclosure with an approved sealing compound. Seals shall be of sufficient strength and durability to protect all energized live parts of the equipment from rodents, insects, or other foreign matter.

3.8.2 Padlocks

Padlocks shall be provided for pad-mounted equipment and for each fence gate. Padlocks shall be keyed as directed by the Contracting Officer.

3.9 CONNECTIONS BETWEEN AERIAL AND UNDERGROUND SYSTEMS

Connections between aerial and underground systems shall be made as required. Underground cables shall be extended up poles in conduit to cable terminations. Conduits shall be secured to the poles by 2-hole galvanized steel pipe straps spaced not more than 10 feet apart and with 1 strap not more than 12 inches from any bend or termination. Cable guards shall be secured to poles in accordance with the manufacturer's published procedures. Conduits shall be equipped with bushings to protect cables and minimize water entry. Capnut potheads shall be used to terminate medium-voltage multiple-conductor cable. Cables shall be supported by devices separate from the conduit or guard, near their point of exit from the conduit or guard. Pole installation shall be in accordance with Section 26 56 00 EXTERIOR LIGHTING.

3.10 CONNECTIONS TO BUILDINGS

Cables shall be extended into the various buildings as indicated, and shall be connected to the first applicable termination point in each building. Interfacing with building interior conduit systems shall be at conduit stubouts terminating 5 feet outside of a building and 3 feet below finished grade as specified and provided under Section 26 20 00 INTERIOR DISTRIBUTION SYSTEM. After installation of cables, conduits shall be sealed with caulking compound to prevent entrance of moisture or gases into buildings.

3.11 GROUNDING

A ground ring consisting of 4/0 AWG bare copper conductors and at least 4 driven ground rods shall be installed around pad-mounted equipment. Equipment frames of metal-enclosed equipment, and other noncurrent-carrying metal parts, such as cable shields, cable sheaths and armor, and metallic conduit shall be grounded. At least 2 connections shall be provided from a transformer, a switchgear ground bus, and a unit substation to the ground

REPAIR AIRFIELD RAMP LIGHTS

ring. Metallic frames and covers of handholes and pull boxes shall be grounded by use of a braided, copper ground strap with equivalent ampacity of No. 6 AWG.

3.11.1 Grounding Electrodes

Grounding electrodes shall be installed as shown on the drawings and as follows:

- a. Driven rod electrodes - Unless otherwise indicated, ground rods shall be driven into the earth until the tops of the rods are approximately 1 foot below finished grade.
- b. Ground ring - A ground ring shall be installed as shown consisting of bare copper conductors installed not less than 30 inches below finished top of soil grade. Ground ring conductors shall be No. 4/0 AWG, minimum.
- c. Additional electrodes - When the required ground resistance is not met, additional electrodes shall be provided interconnected with grounding conductors to achieve the specified ground resistance. The additional electrodes will be up to three, 10 feet rods spaced a minimum of 12 feet apart driven perpendicular to grade. In high ground resistance, UL listed chemically charged ground rods may be used. If the resultant resistance exceeds 25 ohms measured not less than 48 hours after rainfall, the Contracting Officer shall be notified immediately.

3.11.2 Grounding and Bonding Connections

Connections above grade shall be made by the fusion-welding process or with bolted solderless connectors, in compliance with UL 467, and those below grade shall be made by a fusion-welding process. Where grounding conductors are connected to aluminum-composition conductors, specially treated or lined copper-to-aluminum connectors suitable for this purpose shall be used.

3.11.3 Grounding and Bonding Conductors

Grounding and bonding conductors include conductors used to bond transformer enclosures and equipment frames to the grounding electrode system. Grounding and bonding conductors shall be sized as shown, and located to provide maximum physical protection. Bends greater than 45 degrees in ground conductors are not permitted. Routing of ground conductors through concrete shall be avoided. When concrete penetration is necessary, nonmetallic conduit shall be cast flush with the points of concrete entrance and exit so as to provide an opening for the ground conductor, and the opening shall be sealed with a suitable compound after installation.

3.11.4 Surge Arrester Grounding

Surge arresters and neutrals shall be bonded directly to the transformer enclosure and then to the grounding electrode system with a bare copper conductor, sized as shown. Lead lengths shall be kept as short as practicable with no kinks or sharp bends.

REPAIR AIRFIELD RAMP LIGHTS

3.11.5 Manhole, Handhole, or Concrete Pullbox Grounding

Ground rods installed in manholes, handholes, or concrete pullboxes shall be connected to cable racks, cable-pulling irons, the cable shielding, metallic sheath, and armor at each cable joint or splice by means of a No. 4 AWG braided tinned copper wire. Connections to metallic cable sheaths shall be by means of tinned terminals soldered to ground wires and to cable sheaths. Care shall be taken in soldering not to damage metallic cable sheaths or shields. Ground rods shall be protected with a double wrapping of pressure-sensitive plastic tape for a distance of 2 inches above and 6 inches below concrete penetrations. Grounding electrode conductors shall be neatly and firmly attached to manhole or handhole walls and the amount of exposed bare wire shall be held to a minimum.

3.11.6 Metal Splice Case Grounding

Metal splice cases for medium-voltage direct-burial cable shall be grounded by connection to a driven ground rod located within 2 feet of each splice box using a grounding electrode conductor having a current-carrying capacity of at least 20 percent of the individual phase conductors in the associated splice box, but not less than No. 6 AWG.

3.11.7 Riser Pole Grounding

A single continuous vertical grounding electrode conductor shall be installed on each riser pole and connected directly to the grounding electrodes indicated on the drawings or required by these specifications. All equipment, neutrals, surge arresters, and items required to be grounded shall be connected directly to this vertical conductor. The grounding electrode conductor shall be sized as shown. Grounding electrode conductors shall be stapled to wood poles at intervals not exceeding 2 feet.

3.12 FIELD TESTING

3.12.1 General

Field testing shall be performed in the presence of the Contracting Officer. Notify the Contracting Officer 14 days prior to conducting tests. Furnish all materials, labor, and equipment necessary to conduct field tests. Perform all tests and inspections recommended by the manufacturer unless specifically waived by the Contracting Officer. Maintain a written record of all tests which includes date, test performed, personnel involved, devices tested, serial number and name of test equipment, and test results. Field test reports shall be signed and dated by the Contractor.

3.12.2 Safety

Provide and use safety devices such as rubber gloves, protective barriers, and danger signs to protect and warn personnel in the test vicinity. Replace any devices or equipment which are damaged due to improper test procedures or handling.

3.12.3 Ground-Resistance Tests

The resistance of the ground ring shall be measured using the fall-of-potential method defined in IEEE Std 81. Ground resistance measurements shall be made before the electrical distribution system is energized and shall be made in normally dry conditions not less than 48

REPAIR AIRFIELD RAMP LIGHTS

hours after the last rainfall. Resistance measurements of separate grounding electrode systems shall be made before the systems are bonded together below grade. The combined resistance of separate systems may be used to meet the required resistance, but the specified number of electrodes must still be provided.

- a. Single rod electrode - 25 ohms.
- b. Multiple rod electrodes - 10 ohms.
- d. Ground ring - 10 ohms.

3.12.4 Medium-Voltage Cable Test

After installation and before the operating test or connection to an existing system, the medium-voltage cable system shall be given a high potential test. Direct-current voltage shall be applied on each phase conductor of the system by connecting conductors as one terminal and connecting grounds or metallic shieldings or sheaths of the cable as the other terminal for each test. Prior to making the test, the cables shall be isolated by opening applicable protective devices and disconnecting equipment. The test shall be conducted with all splices, connectors, and terminations in place. The method, voltage, length of time, and other characteristics of the test for initial installation shall be for the particular type of cable installed, except that 28 kV and 35 kV insulation test voltages shall be in accordance with either AEIC C8 or AEIC CS8 as applicable, and shall not exceed the recommendations of IEEE Std 404 for cable joints and IEEE Std 48 for cable terminations unless the cable and accessory manufacturers indicate higher voltages are acceptable for testing. Should any cable fail due to a weakness of conductor insulation or due to defects or injuries incidental to the installation or because of improper installation of cable, cable joints, terminations, or other connections, make necessary repairs or replace cables as directed. Repaired or replaced cables shall be retested.

3.12.5 Low-Voltage Cable Test

Low-voltage cable, complete with splices, shall be tested for insulation resistance after the cables are installed, in their final configuration, ready for connection to the equipment, and prior to energization. The test voltage shall be 500 volts dc, applied for one minute between each conductor and ground and between all possible combinations conductors in the same trench, duct, or cable, with all other conductors in the same trench, duct, or conduit. The minimum value of insulation shall be:

R in megohms = (rated voltage in kV + 1) x 1000/(length of cable in feet

Each cable failing this test shall be repaired or replaced. The repaired cable shall be retested until failures have been eliminated.

3.12.6 Liquid-Filled Transformer Tests

The following field tests shall be performed on all liquid-filled transformers. Pass-fail criteria shall be in accordance with transformer manufacturer's specifications.

- a. Insulation resistance test phase-to-ground.

REPAIR AIRFIELD RAMP LIGHTS

- b. Turns ratio test.
- c. Correct phase sequence.
- d. Correct operation of tap changer.

3.12.7 Dry-Type Transformer Tests

The following field tests shall be performed on all dry-type transformers. Pass-fail criteria shall be in accordance with the transformer manufacturer's specifications.

- a. Insulation resistance test phase-to-ground.
- b. Turns ratio test.

3.12.8 Circuit Breaker Tests

The following field tests shall be performed on circuit breakers. Pass-fail criteria shall be in accordance with the circuit breaker manufacturer's specifications.

- a. Insulation resistance test phase-to-phase.
- b. Insulation resistance test phase-to-ground.
- c. Closed breaker contact resistance test.
- d. Power factor test.
- e. High-potential test.
- f. Manual operation of the breaker.

3.12.9 Power Circuit Breaker Tests

The following power circuit breakers shall be tested in accordance with NEMA C37.50.

- a. As specified in NETA ATS.

3.12.10 Protective Relays

Protective relays shall be visually and mechanically inspected, adjusted, tested, and calibrated in accordance with the manufacturer's published instructions. Tests shall include pick-up, timing, contact action, restraint, and other aspects necessary to ensure proper calibration and operation. Relay settings shall be implemented in accordance with the coordination study. Relay contacts shall be manually or electrically operated to verify that the proper breakers and alarms initiate. Relaying current transformers shall be field tested in accordance with IEEE C57.13.

3.12.11 Pre-Energization Services

Calibration, testing, adjustment, and placing into service of the installation shall be accomplished by a manufacturer's product field service engineer or independent testing company with a minimum of 2 years of current product experience. The following services shall be performed

REPAIR AIRFIELD RAMP LIGHTS

on the equipment listed below. These services shall be performed subsequent to testing but prior to the initial energization. The equipment shall be inspected to ensure that installation is in compliance with the recommendations of the manufacturer and as shown on the detail drawings. Terminations of conductors at major equipment shall be inspected to ensure the adequacy of connections. Bare and insulated conductors between such terminations shall be inspected to detect possible damage during installation. If factory tests were not performed on completed assemblies, tests shall be performed after the installation of completed assemblies. Components shall be inspected for damage caused during installation or shipment to ensure packaging materials have been removed. Components capable of being both manually and electrically operated shall be operated manually prior to the first electrical operation. Components capable of being calibrated, adjusted, and tested shall be calibrated, adjusted, and tested in accordance with the instructions of the equipment manufacturer. Items for which such services shall be provided, but are not limited to, are the following:

- a. Secondary unit substation
- b. Pad-mounted transformers
- c. Panelboards
- d. Switchboards
- e. Metal-enclosed switchgear
- f. Busways
- g. Switches

3.12.12 Operating Tests

After the installation is completed, and at such times as the Contracting Officer may direct, conduct operating tests for approval. The equipment shall be demonstrated to operate in accordance with the requirements herein. An operating test report shall be submitted including the following:

- a. A list of equipment used, with calibration certifications.
- b. A copy of measurements taken.
- c. The dates of testing.
- d. The equipment and values to be verified.
- e. The condition specified for the test.
- f. The test results, signed and dated.
- g. A description of adjustments made.

3.13 MANUFACTURER'S FIELD SERVICE

3.13.1 Onsite Training

Conduct a training course for the operating staff as designated by the

REPAIR AIRFIELD RAMP LIGHTS

Contracting Officer. The training period shall consist of a total of 8 hours of normal working time and shall start after the system is functionally completed but prior to final acceptance tests. The course instruction shall cover pertinent points involved in operating, starting, stopping, and servicing the equipment, as well as all major elements of the operation and maintenance manuals. Additionally, the course instructions shall demonstrate all routine maintenance operations.

3.13.2 Installation Engineer

After delivery of the equipment, furnish one or more field engineers, regularly employed by the equipment manufacturer to supervise the installation of the equipment, assist in the performance of the onsite tests, initial operation, and instruct personnel as to the operational and maintenance features of the equipment.

3.14 ACCEPTANCE

Final acceptance of the facility will not be given until the Contractor has successfully completed all tests and after all defects in installation, material or operation have been corrected.

-- End of Section --

The AECOM logo is positioned in the upper right corner of a dark blue vertical bar. It consists of a thin vertical line to the left of the word "AECOM" in a white, sans-serif font. The background of the bar features a faint, abstract pattern of overlapping lines and shapes, suggesting a grid or architectural structure.

AECOM